



2017.
GODINA
LX



GRAĐEVINSKI MATERIJALI I KONSTRUKCIJE

1

BUILDING MATERIALS AND STRUCTURES

ČASOPIS ZA ISTRAŽIVANJA U OBLASTI MATERIJALA I KONSTRUKCIJA
JOURNAL FOR RESEARCH OF MATERIALS AND STRUCTURES

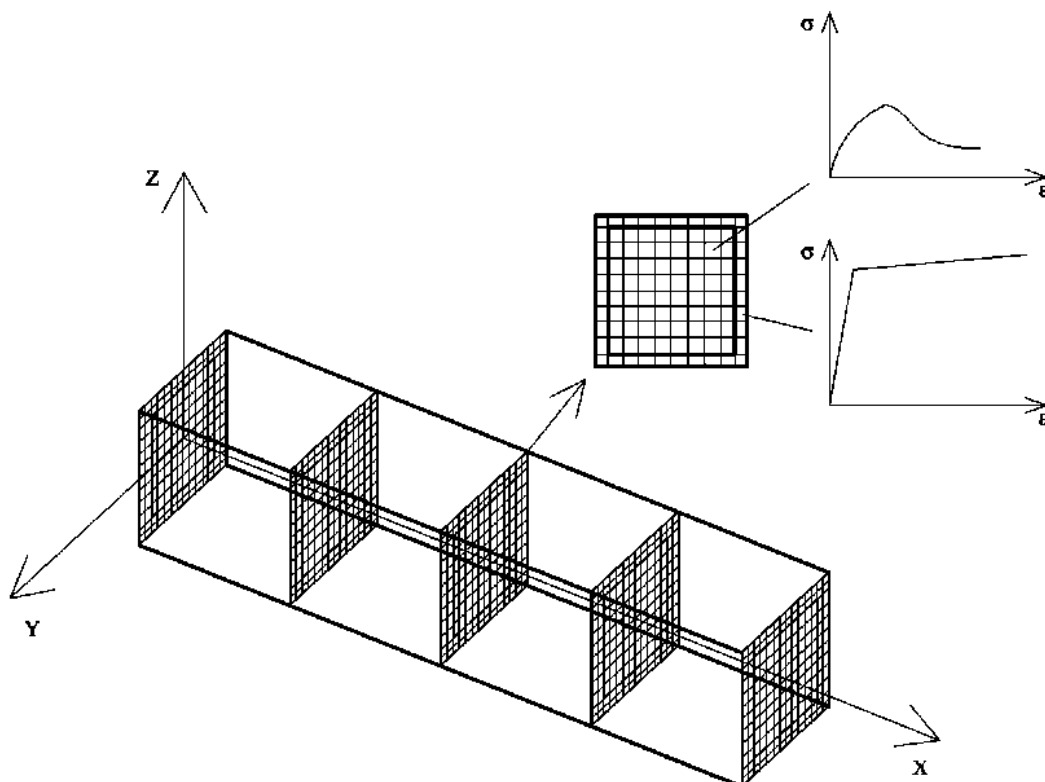

GRAĐEVINSKI MATERIJALI I KONSTRUKCIJE

BUILDING MATERIALS AND STRUCTURES

ČASOPIS ZA ISTRAŽIVANJA U OBLASTI MATERIJALA I KONSTRUKCIJA
JOURNAL FOR RESEARCH IN THE FIELD OF MATERIALS AND STRUCTURES

INTERNATIONAL EDITORIAL BOARD

Professor **Radomir Folić**, Editor in-Chief
Faculty of Technical Sciences, University of Novi Sad, Serbia
Fakultet tehničkih nauka, Univerzitet u Novom Sadu, Srbija
e-mail: folic@uns.ac.rs

Professor **Mirjana Malešev**, Deputy editor
Faculty of Technical Sciences, University of Novi Sad,
Serbia - Fakultet tehničkih nauka, Univerzitet u Novom
Sadu, Srbija, e-mail: miram@uns.ac.rs

Dr **Ksenija Janković**
Institute for Testing Materials, Belgrade, Serbia
Institut za ispitivanje materijala, Beograd, Srbija

Dr **Jose Adam, ICITECH**
Department of Construction Engineering, Valencia,
Spain.

Professor **Radu Banchila**
Dep. of Civil Eng. „Politehnica“ University of
Timisoara, Romania

Professor **Dubravka Bjegović**
University of Zagreb, Faculty of Civil Engineering,
Department of Materials, Zagreb, Croatia

Assoc. professor **Meri Cvetkovska**
Faculty of Civil Eng. University "St Kiril and Metodij",
Skopje, Macedonia

Professor **Michael Forde**
University of Edinburgh, Dep. of Environmental Eng.
UK

Dr **Vladimir Gocevski**
Hydro-Quebec, Montreal, Canada

Sekretar redakcije: **Slavica Živković**, mast.ekon.

Lektori za srpski jezik: Dr **Miloš Zubac**, profesor
Aleksandra Borojev, profesor

Proofreader: Prof. **Jelisaveta Šafranj**, Ph D

Technical editor: **Stoja Todorovic**, e-mail: saska@imk.grf.bg.ac.rs

Acad. Professor **Yachko Ivanov**
Bulgarian Academy of Sciences, Sofia, Bulgaria

Dr. Habil. **Miklos M. Ivanyi**
UVATERV, Budapest, Hungary

Professor **Asterios Liolios**
Democritus University of Thrace, Faculty of Civil
Eng., Greece

Professor **Doncho Partov**
University of Construction and Architecture - VSU
"LJ.Karavelov" Sofia, Bulgaria

Predrag Popović
Wiss, Janney, Elstner Associates, Northbrook,
Illinois, USA.

Professor **Tom Schanz**
Ruhr University of Bochum, Germany

Professor **Valeriu Stoin**
Dep. of Civil Eng. „Poloitehnica“ University of
Timisoara, Romania

Acad. Professor **Miha Tomažević**, SNB and CEI,
Slovenian Academy of Sciences and Arts,

Professor **Mihailo Trifunac**, Civil Eng.
Department University of Southern California, Los
Angeles, USA

PUBLISHER

Society for Materials and Structures Testing of Serbia, 11000 Belgrade, Kneza Milosa 9
Telephone: 381 11/3242-589; e-mail: dimk@ptt.rs, veb sajt: www.dimk.rs

REVIEWERS: All papers were reviewed

KORICE: Konačni element s pet tačaka integracije duž ose

COVER: Finite element with five points of integration along the axis

Financial supports: Ministry of Scientific and Technological Development of the Republic of Serbia

DRUŠTVO ZA ISPITIVANJE I ISTRAŽIVANJE MATERIJALA I KONSTRUKCIJA SRBIJE
SOCIETY FOR MATERIALS AND STRUCTURES TESTING OF SERBIA

GRAĐEVINSKI MATERIJALI I KONSTRUKCIJE

BUILDING MATERIALS AND STRUCTURES

ČASOPIS ZA ISTRAŽIVANJA U OBLASTI MATERIJALA I KONSTRUKCIJA
JOURNAL FOR RESEARCH IN THE FIELD OF MATERIALS AND STRUCTURES

SADRŽAJ

Mladen ČOSIĆ Radomir FOLIĆ Stanko BRČIĆ PREGLED SAVREMENIH SEIZMIČKIH ANALIZA I NAČINA UVOĐENJA PRIGUŠENJA U NJIMA Pregledni rad	3
Nikola BLAGOJEVIĆ Svetlana M. KOSTIĆ Saša STOŠIĆ FIBER KONAČNI ELEMENT U NELINEARNOJ ANALIZI KVADRATNIH SPREGNUTIH CFT STUBOVA Pregledni rad	31
Marija TODOROVIĆ Boško STEVANOVIĆ Ivan GLIŠOVIĆ OJAČANJE DRVENIH GREDA PRIMENOM FRP ŠIPKI Pregledni rad	47
Sonja ČEREPNALKOVSKA Ljubica VLADIČESKA KAKO SMANJITI RIZIK U PROCESU DOKAZIVANJA KVALITETA GRAĐEVINSKIH PROIZVODA Stručni rad	65
Uputstvo autorima	77

CONTENTS

Mladen COSIC Radomir FOLIC Stanko BRCIC AN OVERVIEW OF MODERN SEISMIC ANALYSES WITH DIFFERENT WAYS OF DAMPING INTRODUCTION Review paper	3
Nikola BLAGOJEVIC Svetlana M. KOSTIC Sasa STOSIC FIBER FINITE ELEMENT IN NONLINEAR ANALYSIS OF SQUARE CFT COLUMNS Review paper	31
Marija TODOROVIC Boško STEVANOVIC Ivan GLISOVIC STRENGTHENING OF TIMBER BEAMS USING FRP BARS Review paper	47
Sonja CEREPNALKOVSKA Ljubica VLADICESKA HOW TO REDUCE THE RISK IN THE PROVING PROCESS FOR QUALITY CONSTRUCTION PRODUCTS Professional paper	65
Preview report	77

CIP - Katalogizacija u publikaciji
Narodna biblioteka Srbije, Beograd

620.1

GRAĐEVINSKI materijali i konstrukcije :
časopis za istraživanja u oblasti materijala
i konstrukcija = Building Materials and
Structures : journal for research of
materials and structures / editor-in-chief
Radomir Folić. - God. 54, br. 1 (2011)-
- Beograd (Kneza Miloša 9) : Društvo za
ispitivanje i istraživanje materijala i
konstrukcija Srbije, 2011- (Novi Beograd :
Hektor print). - 30 cm

Tromesečno. - Je nastavak: Materijali i
konstrukcije = ISSN 0543-0798
ISSN 2217-8139 = Građevinski materijali i
konstrukcije
COBISS.SR-ID 188695820



PREGLED SAVREMENIH SEIZMIČKIH ANALIZA I NAČINA UVOĐENJA PRIGUŠENJA U NJIMA

AN OVERVIEW OF MODERN SEISMIC ANALYSES WITH DIFFERENT WAYS OF DAMPING INTRODUCTION

Mladen ČOSIĆ
Radomir FOLIĆ
Stanko BRČIĆ

PREGLEDNI RAD
REVIEW PAPER
UDK:624.042.7
doi:10.5937/grmk1701003C

1 UVOD

U poslednje dve decenije, razvoj metoda za analizu konstrukcija u uslovima dejstva zemljotresa doživeo je naglu ekspanziju. Formiran je niz mogućnosti za rešavanje uobičajenih i kompleksnih problema, kako u svakodnevnoj inženjerskoj praksi, tako i u naučnim istraživanjima. Međutim, ekspanzijom velikog broja ovih metoda pojavio i se niz pitanja među kojima su: *koju metodu, kada i za koji tip konstrukcije je treba primeniti?* Na ova pitanja je delimično dat odgovor u naučnim publikacijama, ali postoje još mnoga pitanja na koja treba odgovoriti putem obimnih istraživanja i komparativnih studija, kako bi se sproveda sistematizacija, definisali algoritmi i dala uputstva za izbor optimalnog tipa metode za analizu konstrukcija u uslovima dejstva zemljotresa. U EN 1998-1:2004 [23] date su samo osnovne preporuke, dok su u propisima ATC 40 [6], FEMA 440 [26], FEMA 750P [27], FEMA P-58-1 [28] i FEMA P-58-2 [29] data dosta detaljnija uputstva kako i gde primeniti koji tip metode analize konstrukcija u uslovima dejstva zemljotresa.

Razvojem savremene opreme, laboratorija za testiranje elemenata, konstruktivnih celina, modela i *in-situ* testiranja realnih konstrukcija omogućeno je kvalitetnije sagledavanje ponašanja i povećan je nivo sigurnosti novoprojektovanih konstrukcija na dejstvo zemljotresa. S druge strane, razvoj savremenih numeričkih metoda i implementacija u softverska rešenja, uz podršku hardver-

1 INTRODUCTION

In the last two decades, development of methods for analysis of structures exposed to earthquake actions saw a rapid expansion. An array of alternatives for solving common and complex problems was formed, both in everyday engineering practice, and in scientific research. However, the expansion of a large number of methods raised a number of questions such as: *Which method, when and for what type of structure should be implemented?* These queries are answered in part through scientific publications, but there is still a large number of questions which should be answered through extensive research and comparative studies, in order to conduct systematization, define algorithms and provide instructions for choice of an optimal type of a method for analysis of structures exposed to earthquake actions. In EN 1998-1:2004 [23] only basic recommendations were given, while in the regulations ATC 40 [6], FEMA 440 [26], FEMA 750P [27], FEMA P-58-1 [28] and FEMA P-58-2 [29] far more detailed instructions were provided of how, where and which type of method should be implemented.

Improvement of contemporary equipment, laboratories for element testing, structural parts, models and *in-situ* testing of actual structures facilitated a better quality of behaviour analysis and safety level of newly designed structures to earthquake actions was increased. On the other hand, development of contemporary numerical

Dr Mladen Čosić, naučni saradnik, Institut za ispitivanje materijala IMS, Beograd, Srbija, mladen.cosic@ymail.com
Profesor emeritus dr Radomir Folić, Univerzitet u Novom Sadu, Fakultet tehničkih nauka, Novi Sad, Srbija, folic@uns.ac.rs
Profesor dr Stanko Brčić, Univerzitet u Beogradu, Građevinski fakultet, Beograd, Srbija, stanko@grf.bg.ac.rs

dr Mladen Čosić, scientific asociate, Institute for Testing of Materials - IMS, Belgrade, Serbia, mladen.cosic@ymail.com
Professor emeritus dr Radomir Folić, University of Novi Sad, Faculty of Technical Sciences, Novi Sad, Sarbia, folic@uns.ac.rs
Professor dr Stanko Brčić, University of Belgrade, Faculty of Civil Engineering, Belgrade, Serbia, stanko@grf.bg.ac.rs

skih resursa čiji se kapacitet konstantno povećava, omogućava simulaciju ponašanja konstrukcija na veoma visokom nivou kvaliteta. Generalno se može konstatovati da je razvoj metoda analize konstrukcija za uslove dejstva zemljotresa u direktnoj korelaciji s nizom faktora, od kojih se izdvajaju: razvoj i unapređivanje instrumenata za kontinualni monitoring dejstva zemljotresa u realnom vremenu, arhiviranje, digitalizacija i razvoj baza podataka zemljotresa koje su dostupne putem interneta, razvoj metoda za obradu i procesiranje seizmičkih signala, unapređivanje eksperimentalnih istraživanja na modelima i realnim konstrukcijama, razvoj računarske mehanike i numeričkih metoda, razvoj tehnika paralelnog procesiranja u visokosofisticiranim naučno-istraživačkim centrima, primena novih metoda i materijala u sanaciji konstrukcija, razvoj novih materijala za izgradnju konstrukcija, unapređivanje postojećih i razvoj novih konstruktivnih sistema, razvoj hibridnih metoda analize konstrukcija, uvođenje multidisciplinarnosti u razmatranje problema, razmena iskustava na globalnom nivou putem predavanja, skupova, kongresa, radionica i publikacija. Najkompleksnija i najobimnija istraživanja sprovode se u visokosofisticiranim naučnim centrima, od kojih se izdvajaju vodeći američki centri: *Earthquake Engineering Research Institute (EERI)*, *Mid-America Earthquake Center (MAE)*, *Multidisciplinary Center for Earthquake Engineering Research (MCEER)*, *Pacific Earthquake Engineering Research Center (PEER)*, *The John A. Blume Earthquake Engineering Center, California Institute of Technology (CALTECH)*, *Network for Earthquake Engineering Simulations (NEES)* i tako dalje. U ovim centrima se razvijaju nova teorijska razmatranja i numeričke analize, sprovode eksperimentalna istraživanja i hibridne simulacije, pri čemu se studioznom pristupom mogu pouzdano proceniti, dodatno unaprediti ili odbaciti postojeće ili čak razviti nove metode analiza konstrukcija za uslove dejstva zemljotresa. S obzirom na to što je u poslednje dve decenije težište istraživanja u oblasti zemljotresnog inženjerstva na analizi performansi konstrukcija prema *Performance-Based Earthquake Engineering (PBEE)* metodologiji, to je veliki broj analiza i razvijen u okviru ove metodologije.

Proračun konstrukcija inženjerskih i arhitektonskih objekata sprovodi se u nekoliko faza, od analize ključnih parametara preko modeliranja konstrukcije, pa sve do selekcije analiza kojima se određuju svojstveni oblici, periodi vibracija, sile u presecima štapova i deformacije. Prilikom kreiranja numeričkog modela konstrukcije definišu se geometrijske i materijalne karakteristike štapova, opterećenje i prigušenje sistema. Na osnovu geometrijskih i materijalnih karakteristika štapova i opterećenja formiraju se matrice krutosti i masa štapova, a zatim i matrice krutosti i masa kompletnog sistema. Proračun geometrijskih karakteristika štapa određuje se iz dimenzija i oblika poprečnog preseka štapa i promene geometrije duž štapa, dok se selekcija materijalnih karakteristika štapa sprovodi prema mehaničkim karakteristikama materijala od koga je formiran štap. Proračun masa na sistemu sprovodi se konvertovanjem opterećenja u mase ili direktnim apliciranjem masa na sistemu. Selekcija parametara prigušenja sistema sprovodi se uzimajući u obzir tip materijala od koga je formiran štap, jedan deo ili kompletna konstrukcija. Standardni postupak uvođenja prigušenja u sistemu zasniiva se

methods and their implementation in software solutions supported by hardware resources whose capacity is continuously increasing, facilitates high quality simulation of structural behaviour. In general, it can be concluded that the development of methods for analysis of structures exposed to earthquake actions is directly correlated to a number of factors, the principal ones being: development and improvement of instruments for continuous monitoring of earthquake actions in real time, archiving, digitalization and development of earthquake data bases which are accessible on the internet, development of methods for processing seismic signals, improvement of experimental research on models and actual structures, development of computer mechanics and numerical methods, development of parallel processing techniques in highly sophisticated scientific-research centres, implementation of new methods and materials in rehabilitation of structures, improvement of the existing and development of new structural systems, development of hybrid methods of structural analysis, introduction of multidisciplinary approach in problem analysis, exchange of experiences on a global level through lectures, meetings, congresses, workshops and publications. The most complex and most extensive research is conducted in highly sophisticated scientific centres, the following centres being the leading ones: *Earthquake Engineering Research Institute (EERI)*, *Mid-America Earthquake Center (MAE)*, *Multidisciplinary Center for Earthquake Engineering Research (MCEER)*, *Pacific Earthquake Engineering Research Center (PEER)*, *The John A. Blume Earthquake Engineering Center, California Institute of Technology (CALTECH)*, *Network for Earthquake Engineering Simulations (NEES)* etc. In these centres new theoretical approaches and numerical analyses are developed as well as experimental research and hybrid simulations are conducted, whereby a meticulous approach can reliably evaluate, additionally improve or reject the existing methods or even develop new methods for analysis of structures exposed to earthquake actions. Considering that in the last two decades the focus of research in the area of earthquake engineering is on the analysis of structural performance according to *Performance-Based Earthquake Engineering (PBEE)* methodology, a large number of analyses is therefore developed within the framework of this methodology.

Engineering and architectural structures are calculated in several stages, from the analysis of key parameters via structural modelling, through the selection of analyses to determine the eigenforms, periods of vibration, forces in bar sections and deformations. The purpose of numerical modelling of the structure is to define the elements' geometric and material properties and the systems' load and damping. These properties and loads make the basis for forming the bars' stiffness and mass matrices, and subsequently the stiffness and mass matrices of the entire system. The method of calculation of bar's geometrical properties is determined based on dimensions and cross-sectional shape of the bar and changes in geometry along the bar, while the material properties of the bar are selected based on the mechanical characteristics of the material from which it is made. The system's mass is calculated by converting loads to masses or by applying masses directly to the system. The choice of system's damping

na definisanju kvantitativne vrednosti koeficijenta relativnog prigušenja ili preko drugih koeficijenata. Međutim, prigušenje se, pored direktnog definisanja u analizi konstrukcija, može uvesti i indirektno.

Analiza i određivanje prigušenja u konstrukcijama sprovodi se eksperimentalnim, analitičkim i numeričkim istraživanjima. Veliki broj eksperimentalnih istraživanja se zasniva na određivanju prigušenja kroz slobodne prigušene oscilacije, a u funkciji logaritamskog dekrementa. Ovakvo prigušenje je u domenu linearno-elastičnog ponašanja, jer se sistem samo izvede iz ravnotežnog položaja i pusti da osciluje. Međutim, ukoliko je pomeranje sistema izazvano dejstvom snažne pobude da osciluje, kao što je dejstvo zemljotresa ili vetra velikog intenziteta, tada se mora razmatrati i histerezisno prigušenje, a koje nastaje usled razvoja nelinearnih deformacija. U analitičkim istraživanjima se rezultati dobijeni eksperimentalnim istraživanjima uvode primenom različitih izraza. Ovi izrazi se, u najvećem broju slučajeva, baziraju na primeni određenih koeficijenata kojim se multipliciraju matrice ili ostali elementi izraza, tako da se prigušenje uvodi eksplicitno ili implicitno. Numerička istraživanja koriste osnovu analitičkih rešenja, pa po analogiji kao inpute za uvođenje prigušenja u sistem koriste niz koeficijenata. Međutim, softveri u kojima je implementirano nelinearno ponašanje sistema omogućavaju da se histerezisno prigušenje određuje preko energije disipacije kroz cikluse nelinearnog ponašanja (histerezisne petlje). S druge strane, u pojedinim softverima je moguće analizirati i slobodne prigušene oscilacije izvodeći sistem iz ravnotežnog položaja i prateći njegov odgovor u vremenskom domenu. Prigušenje se u analizi konstrukcija, najčešće, uvodi kao deo kritičnog prigušenja čije su vrednosti u funkciji tipa materijala, a nezavisno od mase i krutosti sistema [12]. Sa druge strane, primenom ekvivalentnog koeficijenta relativnog prigušenja može se razmatrati prigušenje na različitim tipovima materijala, uvodeći ga u formi kompozitnog prigušenja [1]. Takođe, primenom jedinstvenog ekvivalentnog koeficijenta relativnog prigušenja moguće je uzeti u obzir i viskozno i histerezisno prigušenje u nelinearnoj analizi konstrukcija [48]. Na vrednost koeficijenta relativnog prigušenja utiču kvalitet materijala, amplitude vibracija, period vibracija, svojevrsni oblici, tip veza i konfiguracija konstrukcije [20].

Metodologija nelinearne analize oštećenja objekata izloženih incidentnim, a posebno seizmičkim dejstvima, prikazana je u radu [19]. Predloženi postupak je zasnovan na povezanom nizu nelinearnih analiza kojima se prvo simuliraju kolapsi pojedinačnih stubova prizemlja, sa odgovarajuće izabranim scenarijima, posle čega se vrše nelinearne statičke *pushover* analize za bidirekcijsko seizmičko dejstvo. Matrice krutosti konstrukcije na kraju prethodne analize koriste se kao početne matrice krutosti u narednim analizama. Na kraju analize ciljnog pomeranja izvršena je, primenom metode spektra kapaciteta, procena stanja posmatrane zgrade na osnovu određenih globalnih i međuspratnih driftova i odgovarajućeg koeficijenta oštećenja.

U [46] su razmatrani različiti tipovi prigušenja koji se uvode u analizu konstrukcija, kao što su: materijalno/inercijalno, granično/konstruktivno i fluidno/viskozno prigušenje. Konstruktivni sistemi su razmatrani kao kontinualni (viskozno, *Kelvin-Voigt*, vremenski histerezisno i prostorno histerezisno prigušenje) i diskretni (viskozno,

parameter depends on the type of materials of the element/structure. Quantitative value of coefficient of relative damping or other coefficients are determined in the standard procedure. However, in addition to be directly defined, damping may be also introduced into the structural analysis indirectly.

Structural dampings are determined based on experimental, analytical and numerical research. In many experiments damping is determined from free damped oscillations as a function of logarithmic decrement. This damping is in the domain of linear-elastic behaviour. If the system's displacement is induced by a strong excitation that makes it oscillate (effects of earthquake or strong wind), hysteretic damping should also be taken into considered, which is the consequence of the development of nonlinear strains. Experimental results have enabled introduction of analytical expressions based on the use of specific matrix multipliers, so that damping is introduced either explicitly or implicitly. Numerical studies also use analytical solutions so that damping is introduced into the system through a series of coefficients. Software products which also incorporate nonlinear system behaviour enable hysteretic damping to be determined based on energy dissipation through cycles of nonlinear behaviour (hysteretic loops). Some software solutions enable free damped vibrations to be analyzed by simulating the system's out-of-balance state and monitoring its response in the time domain. Damping has been most commonly introduced into structural analysis as part of critical damping whose values depend on the type of material, and not on the mass and stiffness of the system [12]. By applying the equivalent relative damping coefficient, damping can be analyzed in different types of materials, being introduced in the form of composite damping [1]. Using a unitary equivalent relative damping coefficient in nonlinear structural analysis, both viscous and hysteretic damping can be taken into account [48]. In addition to quality of materials, the value of relative damping coefficient is affected by vibration amplitudes and periods, eigenforms of vibration, types of links and structure's configuration [20].

The methodology of nonlinear analysis of damage to objects exposed to incident, and particularly seismic effects, is shown in [19]. The proposed procedure is based on a related set of nonlinear analyses, which first simulate the collapses of individual ground-floor pillars, with appropriately selected scenarios, followed by nonlinear static pushover analyses of bidirectional seismic action. Structural stiffness matrices at the end of the previous analysis are used as the initial stiffness matrices in subsequent analyses. Finally, the analyses of target displacement were carried out using the Capacity Spectrum Method (CSM), and the assessment of state of the building under consideration is performed on the basis of global and floor drifts and appropriate coefficient of damage.

Paper [46] considers different types of damping introduction into structural analysis: material/inertial, ultimate/structural and fluid/viscous damping. Construction systems are considered as continuous (viscous, *Kelvin-Voigt*, time hysteretic and space hysteretic damping) and discrete (viscous, non-viscous and frequency dependent damping). Generalized approach

neviskozno i frekventno zavisno prigušenje). Generalizovani pristup u analizi prigušenja sistema kroz viskozno i neviskozno prigušenje prikazan je u studiji [2], dok su u [47] razmatrani faktori redukcije pomeranja i ukupne smičuće sile u funkciji prigušenja.

U radu [49] posmatrani su različiti aspekti seizmičkih dejstava u odnosu na „standardne“ aspekte analize ponašanja konstrukcija izloženih seizmičkim dejstvima. Naime, u radu [49] težište je na arhitektonskom i kulturološkom aspektu zgrada koje se svrstavaju u zaštićene objekte, odnosno u nacionalnu kulturnu baštinu. Standardni zahtevi u seizmičkim propisima, kao što su, npr. EN 1998-1:2004, ali i naši stari seizmički propisi, da su dozvoljena oštećenja, ali bez kolapsa prilikom najjačeg zemljotresa, nisu dovoljno prihvatljivi za značajne objekte koji pripadaju kulturnoj baštini. U tom smislu, u radu [49] predložena je detaljnija klasifikacija zaštićenih zgrada u tri kategorije, zavisno od stepena značaja kulturne baštine. U skladu s tim predložene su i odgovarajuće dopune i izmene seizmičkih propisa, kako bi se što bolje zaštitila kulturna dobra ne samo od kolapsa, što je nezamislivo samo po sebi, već i od većih oštećenja.

Cilj istraživanja prikazanog u ovom radu jeste da se sistematizuju metode za analizu konstrukcija u uslovima dejstva zemljotresa i definišu algoritmi modeliranja i načina uvođenja prigušenja u njima u kapacitativnom, vremenskom i frekventnom domenu.

2 OPŠTA SISTEMATIZACIJA SEIZMIČKIH ANALIZA I GENERALNI TRETMAN PRIGUŠENJA U NJIMA

U odnosu na realne fizičke modele objekata, matematički modeli konstrukcija predstavljaju idealizovane modele ponašanja s manjim ili većim stepenom aproksimacije. Analiza propagacije talasa kroz tlo usled dejstva zemljotresa, interakcija konstrukcija–tlo, numeričko modeliranje i analiza konstrukcija izloženih dejstvu zemljotresa konstantno se unapređuju razvojem računarske mehanike. U svakodnevnoj inženjerskoj praksi primenjuju se linearno-elastični modeli ponašanja konstrukcija za analizu statičkih i dinamičkih uticaja. Analize koje pripadaju ovoj grupi su:

- linearna statička analiza (LSA – *Linear Static Analysis*);
 - linearna dinamička analiza (LDA – *Linear Dynamic Analysis*);
- odnosno:
- ekvivalentna statička analiza (ESA – *Equivalent Static Analysis*);
 - spektralna – modalna analiza (SMA – *Spectral – Modal Analysis*).

Uobičajeni postupak primene linearnih proračunskih modela za statičku ili dinamičku analizu ne daje uvid u realno ponašanje zgrada izloženih dejstvu zemljotresa, jer ne uzima u obzir pojavu i razvoj nelinearnih deformacija u nosećoj konstrukciji. Savremene metode za analizu konstrukcija u uslovima dejstva zemljotresa zasnivaju se na primeni nelinearnog ponašanja, uzimajući u obzir razvoj i geometrijske i materijalne nelinearnosti. Analize koje pripadaju ovoj grupi su:

- nelinearna statička analiza (NSA – *Nonlinear Static Analysis*);
- nelinearna dinamička analiza (NDA – *Nonlinear*

to the analysis of the system's damping through viscous and non-viscous damping is shown in the case [2], while [47] considers the factors of reduction in displacement and total shear force as a function of damping.

In [49] various aspects of seismic actions are considered in relation to the "standard" aspects of analysis of behavioural of structures exposed to seismic actions. Here, the focus is on the architectural and cultural aspects of buildings that belong to the group of protected objects, i.e. represent a national cultural heritage. Standard requirements in seismic regulations (EN 1998-1:2004, for example), as well as our old seismic regulations, which allowed damage to occur under the action of the strongest earthquake but no collapse, are not eligible for important objects that belong to the cultural heritage. In this sense, [49] proposes a more detailed classification of protected buildings into three categories, depending on the degree of importance of cultural heritage. In accordance with this, appropriate amendments and changes to seismic regulations are proposed in order to better protect the cultural heritage not only against collapse, which is unthinkable in itself, but also against major damage.

The aim of the research presented in this paper is to systematize methods of analysis of structures in conditions of earthquake action and define modelling algorithms and ways of introducing damping in them in the capacitive, time and frequency domain.

2 GENERAL SYSTEMATIZATION OF SEISMIC ANALYSES AND GENERAL TREATMENT OF DAMPING

In comparison to the actual physical models of structures, mathematical structural models represent idealized behaviour models with a certain extent of approximation. Analysis of wave propagation through the soil due to earthquake actions, soil-structure interaction, numerical modelling and analysis of structures exposed to earthquake action are continuously being improved along with the development of computer mechanics. The linear-elastic models of structural behaviour for analysis of static and dynamic actions are implemented in the everyday engineering practice. Analyses that belong to this group are:

- Linear Static Analysis (LSA),
 - Linear Dynamic Analysis (LDA),
- with respect to:
- Equivalent Static Analysis (ESA),
 - Spectral - Modal Analysis (SMA).

The usual procedure of implementation of linear calculation models for static or dynamic analysis lacks insight in the actual behaviour of structures exposed to earthquake actions, because it fails to consider emergence and development of nonlinear deformations in the bearing structure. Contemporary methods for analysis of structures exposed to earthquake actions are based on implementation of nonlinear behaviour, taking into consideration development and geometrical and material nonlinearities. Analyses that belong to this group are:

- Nonlinear Static Analysis (NSA),
- Nonlinear Dynamic Analysis (NDA).

Dynamic Analysis).

Na slici 1 je prikazan dijagram toka opšte sistematizacije seizmičkih analiza konstrukcija.

Figure 1 shows the flowchart of general systematization of seismic analyses of structures.

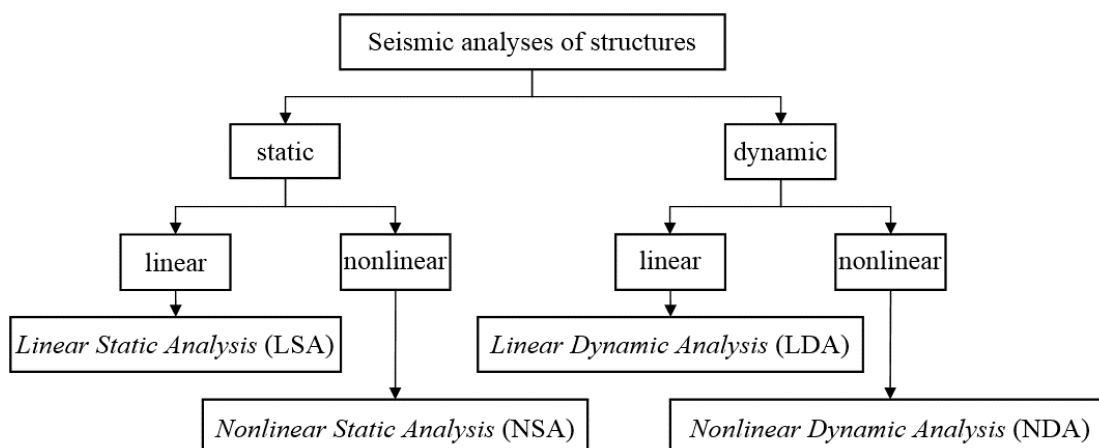

Slika 1. Dijagram toka opšte sistematizacije seizmičkih analiza konstrukcija
Figure 1. Flowchart of general systematization of seismic analyses of structures

Prethodno sistematizovane statičke i dinamičke seizmičke analize konstrukcija proračunavaju se primenom neke od metoda za matematičko-numeričko modeliranje i simulaciju ponašanja konstrukcija. Najveću primenu u rešavanju problema analize konstrukcija prema performansama (PBSD – *Performance-Based Seismic Design*) pronašle su:

- metoda konačnih elemenata (FEM – Finite Element Method);
 - metoda graničnih elemenata (BEM – Boundary Element Method);
- a takođe značajan doprinos u rešavanju problema kolapsa konstrukcija usled dejstva zemljotresa postignut je razvojem:
- metode diskretnih elemenata (DEM – *Discrete Element Method*);
 - proširene metode konačnih elemenata (XFEM – *eXtended Finite Element Method*);
 - metode primenjenih elemenata (AEM – *Applied Element Method*).

S druge strane, postoji niz seizmičkih metoda koje koriste rešenja NSA ili NDA i kombinuju ih s drugim naučnim disciplinama, tako da se problem razmatra multidisciplinarno u PBEE. Sistematizacija ovih metoda je takođe prikazana u radu.

U procesu modeliranja konstrukcije i pripreme seizmičke analize, prema kojoj će se sprovesti proračun konstrukcije, prigušenje je moguće uvesti preko: prigušenja materijala, prigušenja koje potiče od elemenata veze i prigušenja koje se direktno definiše u analizi. Na slici 2 je prikazan dijagram toka generalnog tretmana prigušenja u seizmičkoj analizi konstrukcija. Prigušenje materijala (*material damping*) uvodi se pri definisanju tipa materijala i može se aplicirati za određenu grupu linijskih, površinskih ili prostornih konačnih elemenata. Ovakav princip uvođenja prigušenja u analizu veoma je povoljan, s obzirom na to što je isto moguće definisati za konstrukcije koje se sastoje iz segmenata različitog tipa materijala, kao na primer:

- jedan deo noseće konstrukcije formira se od

Previously classified static and dynamic analyses of structures are calculated by implementing some of the methods for mathematical-numerical modelling and simulation of structural behaviour. The following methods have found the greatest application in solving problems with *Performance-Based Seismic Design* (PBSD):

- Finite Element Method (FEM),
- Boundary Element Method (BEM),

a considerable contribution to solving the problem of structural collapse due to earthquake actions was achieved by the development of

- Discrete Element Method (DEM),
- eXtended Finite Element Method (XFEM),
- Applied Element Method (AEM).

On the other hand, there is a number of seismic analyses which employ solutions of NSA or NDA and combine them with other scientific disciplines so that the problem is considered multidisciplinary in PBEE. Systematization of these analyses is also presented in the paper.

In the process of modelling the structure and preparing seismic analysis based on which the structure will be calculated, damping can be introduced via material damping, link element damping and damping which is directly defined in the analysis. Figure 2 shows the flowchart of general approach to damping in seismic analysis of structures. Material damping is introduced with the definition of the type of material and can be applied to a particular group of line, surface or spatial finite elements. This principle of damping introduction into the analysis is very advantageous, given that enables damping to be also defined for structures consisting of segments made of different types of materials:

- part of the support structure is made of concrete, and part of steel or wood without introduction of coupling,

betona, a drugi deo od čelika ili drveta bez uvođenja sprežanja;

– spregnute konstrukcije beton–čelik, beton–drvo i slično;

– modeliranje konstrukcije sa ispunom, pri čemu je ispunjena od materijala koji se razlikuje od noseće konstrukcije;

– problemi interakcije konstrukcija–tlo (SSI - *soil-structure interaction*), pri čemu se posebno može definisati prigušenje za noseću konstrukciju, a posebno za tlo.

Primenom ovog prigušenja može se uvesti i uticaj radijacijskog prigušenja kod tla, tako što bi se tlo modeliralo prostornim (*solid*) konačnim elementima i za njih bi se definisale odgovarajuće mehaničke karakteristike i prigušenje.

– composite structures of concrete - steel, concrete - wood and the like,

– modelling structure with infill, where the infill material is different from that of the support structure,

– problems of soil-structure interaction (SSI), where damping can be defined separately for the supporting structure, and separately for the soil.

It particularly enables defining damping for the supporting structure, specifically for soil (radiation damping), whereby soil is modelled by using spatial solid finite elements, for which the appropriate mechanical properties and damping will be defined.

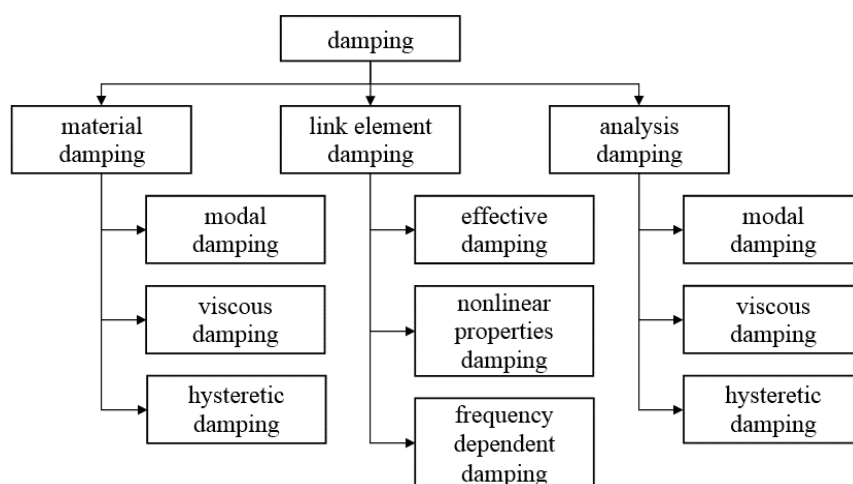

Slika 2. Dijagram toka generalnog tretmana prigušenja u seizmičkoj analizi konstrukcija [30]
Figure 2. Flowchart of general approach to damping in seismic analysis of structures [30]

U zavisnosti od tipa analize, za koju se definiše prigušenje materijala, generalna podela prigušenja može se sprovesti na: modalno (*modal damping*), viskozno (*viscous damping*) i histerezisno prigušenje (*hysteretic damping*). Modalno prigušenje uvodi se kod SMA i modalne LDA i NDA. Viskozno prigušenje uvodi se kod LDA i NDA za koje se sprovodi numerička integracija, dok se histerezisno prigušenje uvodi kod analize stalnog – postojanog stanja (SSA – *Steady - State Analysis*) i analize snage spektralne gustine (PSDA – *Power Spectral Density Analysis*). U zavisnosti od tipa elementa veze (*link element*), prigušenje se može uvesti kao: efektivno prigušenje (*effective damping*), prigušenje kod nelinearnog ponašanja i prigušenje kod frekventno zavisnih elemenata veze. Efektivno prigušenje se uvodi kod: SMA, LDA i NDA (modalna i numerička integracija), SSA i PSDA. Prigušenje kod frekventno zavisnih elemenata veze uvodi se kod SSA i PSDA. U zavisnosti od tipa analize, generalna podela prigušenja se može sprovesti na: modalno, viskozno i histerezisno prigušenje. Svako ovo prigušenje može se uvesti primenom različitih postupaka koji su prikazani u daljem delu teksta.

Depending on the type of analysis for which material damping is being defined, damping can be generally divided into modal, viscous, and hysteretic damping. Modal damping is introduced into SMA and modal LDA/NDA. Viscous damping is introduced into LDA/NDA which requires numerical integration to be carried out, while hysteretic damping is introduced into *Steady-State Analysis* (SSA) and *Power Spectral Density Analysis* (PSDA). Depending on the type of the link element, damping can be introduced as: effective damping, damping in nonlinear behaviour and damping of frequency dependent link elements. Effective damping is introduced into SMA, LDA (modal and numerical integration), SSA and PSDA. In frequency dependent link elements damping is introduced into SSA and PSDA. Depending on the type of analysis, damping can be generally divided to: modal, viscous and hysteretic damping. Each of the damping can be introduced by applying different procedures presented later in this paper.

2.1 Prigušenje materijala

Prigušenje materijala, u formi modalnog prigušenja, uvodi se primenom koeficijenta relativnog prigušenja ξ_m za različite tipove materijala, a koji predstavlja odnos realnog prigušenja i kritičnog prigušenja i za koji se može pisati:

$$\xi_{m,i} \neq \xi_{m,j} \neq \xi_{m,k} \dots \neq \xi_{m,n} \quad (1)$$

pri čemu se indeksirano i odnosi na i -ti materijal koji se koristi u analizi. Ovo prigušenje je poznato i kao kompozitno modalno prigušenje, a njegove vrednosti se nalaze u granicama $0 \leq \xi_m \leq 1$. Prigušenje materijala, u formi viskoznog (proporcionalnog) prigušenja, uvodi se primenom faktora participacije mase i krutosti sistema, tako da se proračun matrice prigušenja sprovodi prema [52]:

$$[C] = \alpha[M] + \beta[K], \quad (2)$$

$$\alpha = 4\pi \frac{T_1 \xi_1 - T_2 \xi_2}{T_1^2 - T_2^2}, \quad \beta = \frac{1}{\pi} T_1 T_2 \frac{T_1 \xi_2 - T_2 \xi_1}{T_1^2 - T_2^2}, \quad (3)$$

gde su α i β faktori participacije matrice masa i matrice krutosti u matrici prigušenja sistema, T_1 i T_2 periodi vibracija za prvi i drugi svojstveni oblik, ξ_1 i ξ_2 koeficijenti relativnog prigušenja za prvi i drugi svojstveni oblik. Veza između koeficijenata relativnog prigušenja za prvi i drugi svojstveni oblik i faktora participacije matrice masa i matrice krutosti u matrici prigušenja sistema glasi:

$$\xi_1 = \frac{\alpha}{2\omega_1} + \frac{\beta\omega_1}{2}, \quad \xi_2 = \frac{\alpha}{2\omega_2} + \frac{\beta\omega_2}{2}, \quad (4)$$

gde su ω_1 i ω_2 ugaone frekvencije za prvi i drugi svojstveni oblik. Ukoliko su koeficijenti relativnog prigušenja jednaki za oba svojstvena oblika vibracija $\xi_1 = \xi_2 = \xi$, tada izraz (3) postaje:

$$\alpha = \xi \frac{2\omega_1\omega_2}{\omega_1 + \omega_2}, \quad \beta = \xi \frac{2}{\omega_1 + \omega_2}. \quad (5)$$

Prigušenje materijala, u formi histerezisnog prigušenja, uvodi se primenom faktora participacije mase i krutosti sistema, analogno principu uvođenja viskoznog prigušenja. Budući da se ovo prigušenje uvodi kod analiza u frekventnom domenu, to se u proračunu primenjuje matrica histerezisnog prigušenja [52]:

$$[D] = \omega[C]. \quad (6)$$

2.2 Prigušenje koje potiče od elemenata veze

Prigušenje koje potiče od elemenata veze, a koji se modeliraju kod linearnih analiza, definiše se preko efektivnog prigušenja c_{eff} . Ovo efektivno prigušenje se uvodi za svaki element veze posebno i za svaku komponentu prigušenja nezavisno (ima ih šest), a njime se može predstaviti, između ostalog, i energija disipacije

2.1 Material damping

Material damping, in the form of modal damping, is introduced using relative damping coefficient ξ_m for different types of materials, which represents the ratio of actual and critical damping, wherein:

where the indexed i refers to the i -th material used in the analysis. This damping is also known as composite modal damping, and its values are within the limits of $0 \leq \xi_m \leq 1$. Material damping, in the form of a viscous (proportional) damping is introduced by applying the factors of participation of the system's mass and stiffness, so that the damping matrix is calculated as follows [52]:

where α and β are factors of participation of mass and stiffness matrices in the system's damping matrix, T_1 and T_2 are periods of vibration for the first and second eigenform, ξ_1 and ξ_2 are relative damping coefficients for the first and second eigenform. The relation between the relative damping coefficient for the first and second eigenform and the factor of participation of mass matrix and stiffness matrix in the system's damping matrix is as follows:

where ω_1 and ω_2 are angular frequencies for the first and second eigenform. If relative damping coefficients are the same for both eigenforms of vibrations $\xi_1 = \xi_2 = \xi$, then the expression (3) becomes:

Material damping, in the form of hysteretic damping, is introduced by applying the factors of participation of the system's mass and stiffness, analogous to the principle of introduction of viscous damping. Given that this damping is being introduced in analyses in the frequency domain, the calculation uses the hysteretic damping matrix [52]:

2.2 Damping induced by link elements

Damping induced by link elements, which are modelled in linear analyses, is defined through effective damping c_{eff} . This effective damping is introduced individually for each link element and independently for each of the 6 damping components. Besides, it can be used for representing energy dissipation due to nonlinear

usled nelinearnog prigušenja i razvoja plastičnih deformacija. Određivanje efektivnog prigušenja sprovodi se analogno određivanju komponenata efektivne krutosti. Ukoliko se element veze definiše s mogućnošću razvoja nelinearnih deformacija, tada se u toku nelinearne analize proračunava disipacija histerezisne energije u elementima veze. S druge strane, postoji mogućnost da se pri nelinearnom ponašanju elemenata veze dodatno uvede prigušenje, a u funkciji tipa samog elementa veze. U slučaju elementa prigušivača (*dampner element*), relacija nelinearna sila – pomeranje glasi [52]:

$$f_d = cv^e, \quad (7)$$

gde je f_d sila u elementu prigušivaču, c koeficijent prigušenja ($c=\xi c_c$ – proizvod koeficijenta relativnog prigušenja i koeficijenta kritičnog prigušenja), v brzina deformacije u elementu prigušivaču, e eksponent prigušenja ($0.2 \leq e \leq 2$). Kod frikcionog izolatora (*friction – pendulum insulator*) prigušenje se uvodi u analizi aksijalne sile f_i :

$$f_i = kd + cv, \quad (8)$$

gde je k krutost izolatora, d pomeranje izolatora, pri čemu se koeficijent relativnog prigušenja ξ može odrediti prema:

$$\xi = \frac{c}{2\sqrt{km}}, \quad (9)$$

gde je m odgovarajuća masa izolatora. U slučaju biaksijalnog frikcionog izolatora (*double - acting friction - pendulum insulator*) ovo prigušenje se uvodi u analizi aksijalne sile preko:

$$f_i = cv + \begin{cases} k_c(d + \Delta_c) & \text{ukoliko je / if } (d + \Delta_c) < 0 \\ k_t(d - \Delta_t) & (d - \Delta_c) > 0, \\ 0 & \text{ostalo / other} \end{cases} \quad (10)$$

gde je k_c krutost izolatora pri pritisku, k_t krutost izolatora pri zatezanju, Δ_c zazor otvora (*gap*) pri pritisku, Δ_t zazor otvora pri zatezanju. U slučaju ostalih tipova elemenata veze koji se zasnivaju na histerezisnom ponašanju, kao što su multiliniarni plastični (*multilinear plastic*), plastični (*Wen*) i izolator od gume (*rubber insulator*), a koji se primenjuju kod nelinearnih analiza, prigušenje se eksplicitno ne uvodi u proračun, već se u toku analize određuje.

Prigušenje frekventno zavisnih elemenata veze koristi se kod analize u frekventnom domenu, pri čemu frekventno zavisne karakteristike predstavljaju kompleksnu impedancu. Realni deo odgovara krutosti, dok imaginarni deo odgovara histerezisnom prigušenju. Frekventno zavisne karakteristike elementa veze sa šest stepeni slobode mogu se prikazati u matricnoj formi (36 elemenata), pri čemu je element matrice impedance [14]:

$$z_i = k_i + ic_i, \quad (11)$$

gde je k_i komponenta krutosti za i -ti stepen slobode, c_i komponenta prigušenja za i -ti stepen slobode.

damping and development of plastic strains. Effective damping is determined analogous to determining the components of the effective stiffness. If the link element is defined based on the possibility of developing nonlinear strains, then dissipation of hysteretic energy in link elements is required to be calculated during the nonlinear analysis. On the other hand, in the case of nonlinear behaviour of link elements, damping can be additionally introduced depending on the type of the link element. In the case of damper element, the relation between nonlinear forces and displacements is as follows [52]:

where f_d is the force in the damper element, c is the damping coefficient ($c=\xi c_c$ - product of the relative and critical damping coefficient), v is the strain rate in the damper element, e is the damping exponent ($0.2 \leq e \leq 2$). In friction-pendulum insulator, damping is introduced in the axial force analysis f_i :

where k is insulator stiffness, d is insulator displacement, while relative damping coefficient ξ can be determined from:

where m is the corresponding insulator mass. In the case of double-acting friction-pendulum insulator, this damping is introduced in axial force analysis through:

where k_c is the insulator's compressive stiffness, k_t is the insulator's tensile stiffness, Δ_c is the clearance gap under compression and Δ_t is the clearance gap under tension. In the case of other types of link elements which are based on hysteretic behaviour, such as multi linear plastic, *Wen* and rubber insulators, which can be applied in nonlinear analyses, damping is explicitly left out from calculation, but determined during the analysis.

Damping of frequency dependent link elements is used in analysis in frequency domain, where the complex impedance is represented by frequency dependent properties. The real part corresponds to stiffness, while imaginary part corresponds to hysteretic damping. Frequency dependent properties of link element with six degrees of freedom can be expressed in matrix form (36 elements), wherein the element of impedance matrix [14]:

where k_i is the stiffness component for the i -th degree of freedom, c_i is the damping component for the i -th degree of freedom.

2.3 Prigušenje koje se direktno definiše u analizi

Modalno prigušenje, koje se direktno definiše u analizi, može se uvesti kao: konstantno prigušenje (*constant damping for all modes*), interpolirano prigušenje (*interpolated damping by period or frequency*) i primenom faktora participacije mase i krutosti (*mass and stiffness proportional damping by coefficient*). Konstantno prigušenje se definiše primenom jedinstvenog koeficijenta relativnog prigušenja ξ_c . Ukoliko se u postupku modeliranja konstrukcije definiše samo jedan tip materijala, tada prigušenje koje se uvodi preko materijala ξ_m postaje ekvivalentno prigušenju koje se uvodi kao konstantno prigušenje u analizi ξ_c . Međutim, potrebno je uzeti u obzir da se ovi tipovi prigušenja, različiti po postupku uvođenja, sabiraju, tako da će ukupno prigušenje biti dodatno povećano. Interpolirano prigušenje ξ_i se definiše u funkciji selektovanih perioda vibracija T_i ili frekvencija f_i . Ovde postoji mogućnost da se za određene periode vibracija (frekvencije) posebno definišu koeficijenti relativnog prigušenja, a zatim da se za proračunate periode vibracija (frekvencije) interpolacijom odrede odgovarajući koeficijenti relativnog prigušenja $\xi_{i,i}$.

$$\xi_{i,i} = f(T_i) \vee \xi_{i,i} = f(f_i), \quad i = 1, \dots, n. \quad (12)$$

Van definisanog regiona, u kojem je zadato prigušenje, vrednost koeficijenta relativnog prigušenja je konstantna. Uvođenje prigušenja u analizu primenom faktora participacije mase i krutosti sistema sprovodi se: direktnim definisanjem ovih koeficijenata, definisanjem ovih koeficijenata u funkciji perioda vibracija prvog i drugog svojstvenog oblika i definisanjem ovih koeficijenata u funkciji frekvencija prvog i drugog svojstvenog oblika. U određenim softverskim rešenjima postoji mogućnost direktnog definisanja α i β faktora ili da se definišu periodi vibracija prvog i drugog svojstvenog oblika T_1 i T_2 i odgovarajuće vrednosti koeficijenata relativnog prigušenja ξ_1 i ξ_2 , a da se zatim sprovede proračun α i β faktora. Takođe, postoji mogućnost da se definišu frekvencije prvog i drugog svojstvenog oblika f_1 i f_2 i odgovarajuće vrednosti koeficijenata relativnog prigušenja ξ_1 i ξ_2 , a da se zatim sprovede proračun α i β faktora. Proračun matrice prigušenja se može sprovesti prema [35]:

$$[C] = \alpha[I] + \beta[\Omega^2], \quad (13)$$

gde je $[\Omega^2]$ matrica kvadrata svojstvenih vrednosti sistema, $[I]$ jedinična matrica.

Viskozno prigušenje, koje se direktno definiše u analizi, može se uvesti: primenom faktora participacije mase i krutosti α i β , u funkciji perioda vibracija prvog i drugog svojstvenog oblika T_1 i T_2 (*specify damping by period*) i u funkciji frekvencija prvog i drugog svojstvenog oblika f_1 i f_2 (*specify damping by frequency*). U slučaju uvođenja faktora participacije mase i krutosti α i β proračun matrice prigušenja $[C]$ sprovodi se prema izrazu (2), dok je u preostala dva postupka potrebno poznavati i periode vibracija T_1 i T_2 ili frekvencije f_1 i f_2 i odgovarajuće koeficijente relativnog prigušenja ξ_1 i ξ_2 da bi se proračunala matrica prigušenja $[C]$. Uvođenje prigušenja primenom različitih koeficijenata relativnog prigušenja za prva dva svojstvena oblika (frekvencije) ima niz prednosti, u odnosu na princip korišćenja jedinstvenog koeficijenta relativnog prigušenja.

2.3 Damping that is directly defined in the analysis

Modal damping that is directly defined in the analysis can be introduced as: constant damping for all modes, interpolated damping by period or frequency and applying the factors of mass and stiffness proportional damping by coefficient. Constant damping for all modes is defined by applying a unique relative damping coefficient of ξ_c . If only one type of material is defined in the process of structural modelling, then damping that is introduced through the material ξ_m becomes equivalent to damping which is introduced as a constant damping in the analysis of ξ_c . However, it is necessary to take into account that these differently introduced types of damping are added up, so that overall damping will be further increased. Interpolated damping ξ_i is defined as a function of selected vibration T_i or frequency f_i periods. Here, for certain periods of vibration (frequency) it is possible to separately define relative damping coefficients, and then, using interpolation, to determine the corresponding relative damping coefficients $\xi_{i,i}$ for the calculated periods of vibrations (frequencies).

Outside the defined region, where damping is predefined, the value of the relative damping coefficient is constant. Introduction of damping in the analysis by using mass participation factor and system stiffness is carried out in the following ways: by defining these coefficients directly, defining these coefficients as a function of the period of vibration of the first and second eigenform, and defining these coefficients as a function of frequencies of the first and second eigenform. Some software solutions allow defining factors α and β directly or defining periods of vibration of the first and second eigenform T_1 and T_2 , and the corresponding values of relative damping coefficients ξ_1 and ξ_2 , which is then followed by the calculation of factors α and β . It is also possible to define the frequencies of the first and second eigenform f_1 and f_2 and the corresponding values of relative damping coefficients ξ_1 and ξ_2 , and then to perform the calculation for factors α and β . Damping matrix can be calculated using the following formula [35]:

where $[\Omega^2]$ is the matrix of squares of the system's eigenvalues and $[I]$ is the unit matrix.

Viscous damping, which is directly defined in the analysis, can be introduced by: using factors of mass and stiffness participation (α and β) as a function of vibration periods of the first and second eigenform T_1 and T_2 (*specify damping by a period*) and as a function of frequencies of the first and second eigenform f_1 and f_2 (*specify dumping by frequency*). In the case of introducing the mass and stiffness participation factors α and β , the damping matrix $[C]$ is calculated according to the expression (2), while in the remaining two procedures it is required to identify periods of vibration T_1 and T_2 or frequencies f_1 and f_2 , and corresponding relative damping coefficients ξ_1 and ξ_2 to calculate the damping matrix $[C]$. Introducing damping by using different relative damping coefficients for the first two eigenforms (frequency) has a number of advantages

Histeretizno prigušenje, koje se direktno definiše u analizi, može se uvesti kao konstantno prigušenje za sve frekvencije (*constant damping for all frequencies*) i interpolirano prigušenje po frekvencijama (*interpolated damping by frequency*). Konstantno prigušenje za sve frekvencije se definiše preko faktora participacije mase i krutosti α i β , tako da se proračun matrice prigušenja $[C]$ sprovodi prema izrazu (2). Interpolirano prigušenje po frekvencijama se uvodi u proračun preko frekvencija f_i i odgovarajućih faktora participacije mase i krutosti α i β . Zatim se za proračunate frekvencije interpolacijom odrede odgovarajući koeficijenti relativnog prigušenja $\xi_{h,i}$.

3 LINEARNA STATIČKA ANALIZA (LSA)

Linearna statička analiza (LSA – *Linear Static Analysis*) koristi se u svakodnevnoj inženjerskoj praksi za proračun konstrukcija na seizmičko dejstvo prema propisima. Proračun se sprovodi tako što se primenom ekvivalentne statičke analize (ESA – *Equivalent Static Analysis*) ili spektralne – modalne analize (SMA – *Spectral - Modal Analysis*) odrede lateralne seizmičke sile, koje se apliciraju na konstrukciju. Zatim se primenom LSA po FEM ili sličnim metodama sprovede proračun, a nakon toga dimenzionisanje konstruktivnih elemenata. Na slici 3 prikazan je dijagram toka proračuna primenom LSA u interakciji sa ESA i SMA.

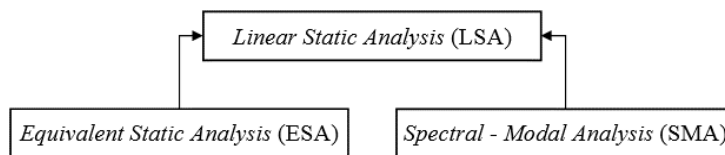

Slika 3. Dijagram toka proračuna primenom LSA u interakciji sa ESA i SMA
Figure 3: Flowchart of calculation using LSA in interaction with ESA and SMA

Uvođenje prigušenja u SMA moguće je sprovesti primenom: prigušenja materijala, prigušenja elemenata veze i prigušenja u analizi. Na slici 4 je prikazan dijagram toka uvođenja prigušenja kod SMA.

Prigušenje materijala uvodi se kao modalno prigušenje, dok se prigušenje elemenata veze uvodi kao efektivno prigušenje. Prigušenje koje se direktno definiše u analizi uvodi se kao: konstantno prigušenje, interpolirano prigušenje i primenom faktora participacije mase i krutosti, pri čemu se ovo poslednje prigušenje može uvesti primenom: faktora participacije mase i krutosti α i β , u funkciji perioda vibracija prvog i drugog svojstvenog oblika T_1 i T_2 i u funkciji frekvencija prvog i drugog svojstvenog oblika f_1 i f_2 . S druge strane, prilikom generisanja spektra odgovora prigušenje se uvodi preko koeficijenta relativnog prigušenja ξ_{rs} . Međutim, ukupno prigušenje u SMA definiše se preko kumulativnog koeficijenta relativnog prigušenja ξ , tako da se kriva spektra odgovora koriguje prema [43]:

$$S_a = S_{a,rs} \frac{2.31 - 0.41 \cdot \log \xi}{2.31 - 0.41 \cdot \log \xi_{rs}}, \quad (14)$$

over the principle of using a unique relative damping coefficient.

Hysteretic damping, which is directly defined in the analysis, can be introduced as constant damping for all frequencies and interpolated damping by frequency. Constant damping for all frequencies is defined through the factors of mass and stiffness participation (α and β), so that the damping matrix $[C]$ can be calculated using expression (2). Interpolated damping across the frequencies is introduced into calculation over the frequencies f_i and corresponding mass and stiffness participation factors α and β . Then the corresponding relative damping coefficients $\xi_{h,i}$ are determined for calculated frequencies using interpolation.

3 LINEAR STATIC ANALYSIS (LSA)

LSA is used in everyday engineering practice for calculating the structures against seismic actions in accordance with the regulations. First, lateral seismic forces which are applied to the structure are determined using *Equivalent Static Analysis* (ESA) or *Spectral-Modal Analysis* (SMA). Then, the calculation is conducted using the LSA to FEM or similar methods, after which dimensioning of structural elements is carried out. Figure 3 shows a flowchart of calculation using LSA in interaction with ESA and SMA.

Damping can be introduced into LSA by using: material damping, link element damping and analysis damping. Figure 4 shows the flowchart of introducing damping into LSA.

Material damping is introduced as a modal damping, while the link element damping is introduced as effective damping. The damping which is directly defined in the analysis is introduced as: constant damping, interpolated damping, using the factors of mass and stiffness participation, whereby the latter can be introduced by using the factors of mass and stiffness participation (α and β) as a function of the vibration period of the first and second eigenform T_1 and T_2 , and as a function of frequencies f_1 and f_2 . On the other hand, when generating the response spectrum, damping is introduced through the relative damping coefficient ξ_{rs} . However, overall damping in the SMA is defined through the cumulative relative damping coefficient ξ , so that the response spectrum curve is corrected according to [43]:

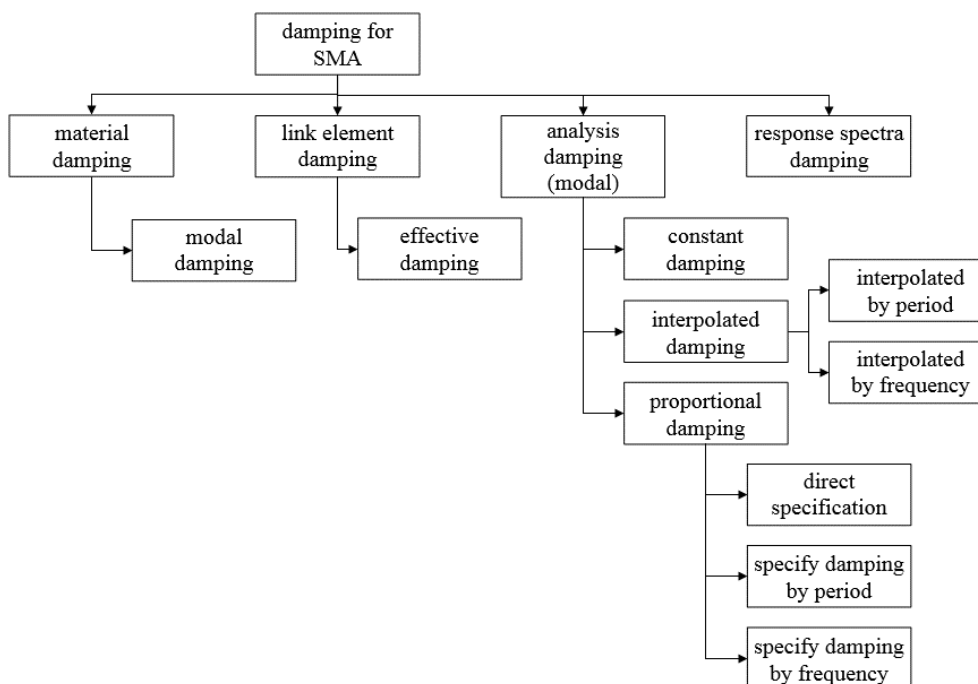

Slika 4. Dijagram toka uvođenja prigušenja kod SMA [30]
 Figure 4. Flowchart of introducing damping into LSA [30]

gde je S_a korigovana spektralna akceleracija koja odgovara prigušenju ξ , $S_{a,rs}$ inicijalna spektralna akceleracija koja odgovara prigušenju ξ_{rs} . Ukoliko su vrednosti koeficijenta relativnih prigušenja jednake $\xi_{rs}=\xi$, tada nema dodatne korekcije spektralnih akceleracija i u analizu se uvodi spektar odgovora koji je generisan za koeficijent relativnog prigušenja ξ_{rs} . Diferencijalne jednačine kretanja sistema sa više stepeni slobode mogu da se transformišu u nezavisne jednačine dobijajući izraz [52]:

$$\{\ddot{Y}\} + [C]\{\dot{Y}\} + [\Omega^2]\{Y\} = [\Phi]^T \{F\}, \quad (15)$$

gde je $\{Y\}$ vektor modalnih koordinata, $[\Phi]$ modalna matrica čije su kolone svojstveni oblici, $\{F\}$ vektor opterećenja sistema. Zbog dijagonalne strukture matrice prigušenja, jednačine su nezavisne (15) i imaju oblik:

$$\ddot{y}_i(t) + 2\xi_i\omega_i\dot{y}_i(t) + \omega_i^2 y_i(t) = r(t), \quad r(t) = \{\Phi\}_i^T \{F\}, \quad (16)$$

gde je $\{\Phi\}_i$ kolona i matrice $[\Phi]$. Prilikom proračuna SMA formira se matrica prigušenja prema izrazu (15), odnosno definišu se koeficijenti relativnog prigušenja prema izrazu (16).

4 NELINEARNA STATIČKA ANALIZA (NSA)

Nelinearna statička analiza (NSA – *Nonlinear Static Analysis*) sprovodi se u kapacitativnom domenu, a poznatija je kao *pushover* analiza ili *Nonlinear Static Pushover Analysis* (NSPA). Na abscisi i ordinati kapacitativnog domena predstavljaju se parametri inženjerskog zahteva (EDP – *engineering demand*

where S_a is the corrected spectral acceleration corresponding to damping ξ , and $S_{a,rs}$ is the initial spectral acceleration corresponding to damping ξ_{rs} . If values of relative damping coefficients are the same $\xi_{rs}=\xi$, then no further corrections of spectral accelerations are needed and the response spectrum which is generated for relative damping coefficient ξ_{rs} introduced in the analysis. Differential equations of movement of the system with several degrees of freedom can be transformed in independent equations, leading to the following expression [52]:

where $\{Y\}$ is the vector of modal coordinates, $[\Phi]$ is the modal matrix whose columns are eigenforms, and $\{F\}$ is the load vector of the system. Due to the diagonal structure of the damping matrix, equations (15) are independent and have the following form:

where $\{\Phi\}_i$ is the i column of matrix $[\Phi]$. When calculating the SMA, the damping matrix forms according to expression (15), and relative damping coefficients are defined according to expression (16).

4 NONLINEAR STATIC ANALYSIS (NSA)

NSA is conducted in capacitive domain, and it is more known as *pushover* analysis or *Nonlinear Static Pushover Analysis* (NSPA). On the abscise and ordinate of the capacitive domain, engineering demand parameters (EDP) are displayed, which are actually structural response parameters. *Target Displacement*

parameters), a što su zapravo parametri odgovora konstrukcije. Kao dopuna konačnog rešenja koje se dobija NSPA, sprovodi se i analiza ciljnog pomeranja (TDA – *target displacement analysis*). NSPA se sprovodi na realnom sistemu s više stepeni slobode (MDOF – *multi degree of freedom*), dok se TDA sprovodi za sistem s jednim stepenom slobode (SDOF – *single degree of freedom*) ili se direktno proračun sprovodi na osnovu realizovane *pushover* krive. Razvoj koncepta NSPA i TDA zgrada, za uslove seizmičkog dejstva, iniciran je pre više od dve decenije, a zvanične implementacije su usledile u ATC 40 [6], EN 1998-1:2004 [23], FEMA 356 [25] i FEMA 440 [26] propise. Danas postoji širok spektar NSPA i TDA. Kod određenih analiza se direktno sprovodi proračun ciljnog pomeranja kroz NSPA (integrirano rešenje), dok se kod određenih analiza ovo sprovodi nezavisno (sukcesivno rešenje). U ovom drugom slučaju je moguće kombinovati rešenja NSPA i TDA primenom različitih pristupa. Takođe, bitan faktor koji se može uzeti u obzir pri klasifikaciji ovih analiza jeste tip lateralnog seizmičkog opterećenja. Dakle, izdvajaju se tri ključna faktora koji determinišu razlike u ovim analizama: tip NSPA, tip TDA i tip lateralnog seizmičkog opterećenja. Sistematizacija NSPA prikazana je bez detaljnijeg klasifikovanja ovih analiza, s tim što se za ove analize koriste različiti tipovi inkrementalno-iterativnih algoritama. Analize koje pripadaju ovoj grupi su [31]:

- nelinearna statička konvencionalna *pushover* analiza (NSCPA – *Nonlinear Static Conventional Pushover Analysis*);
- nelinearna statička adaptivna *pushover* analiza (NSAPA – *Nonlinear Static Adaptive Pushover Analysis*);
- modalna *pushover* analiza (MPA – *Modal Pushover Analysis*);
- multimodalna *pushover* procedura (MMPP – *Multi-Mode Pushover Procedure*);
- metod modalnih kombinacija (MMC – *Method of Modal Combinations*);
- inkrementalna analiza spektra odgovora (IRSA – *Incremental Response Spectrum Analysis*);
- projektovanje konstrukcija prema performansama plastifikacije (PBPD – *Performance-Based Plastic Design*);
- nelinearna statička *pushover* analiza zasnovana na analizi mehanizama loma (NSPA-DMBD – *Nonlinear Static Pushover Analysis - Damage Mechanisms-Based Design*).

Na slici 5 je prikazana podela NSA prema postupku proračuna. NSCPA se zasniva na konstantnom zadržavanju raspodele lateralnog seizmičkog opterećenja kroz sve faze inkrementalno-iterativne analize, odnosno od inicijalnog linearnog to finalnog kolapsnog stanja konstrukcije [4]. NSAPA se zasniva na korekciji lateralnog seizmičkog opterećenja po inkrementima, uzimajući u obzir promenu perioda vibracija konstrukcije i spektralnu amplifikaciju seizmičkih sila prema spektru odgovora ubrzanja ili korekciju pomeranja prema spektru pomeranja [3]. Kontrola inkrementalnog koncepta za NSCPA i NSAPA moguća je preko sila (FBA – *Force-Based Analysis*) ili preko pomeranja (DBA – *Displacement-Based Analysis*). U zavisnosti od toga kako se sprovodi korekcija lateralnih apliciranih sila, moguće su opcije: totalna (TU), inkrementalna (IU) i hibridna (HU) korekcija. U zavisnosti od primenjene

Analysis(TDA) is conducted as a complement of the final solution obtained by NSPA. NSPA is conducted on an actual multi degree of freedom (MDOF) system, while the TDA is conducted on a single degree of freedom system (SDOF) or calculation is directly conducted based on the realized pushover curve. Development of the concept of NSPA and TDA of the buildings designed for seismic areas was initiated more than two decades ago, and official implementations were effected in ATC 40 [6], EN 1998-1:2004 [23], FEMA 356 [25] and FEMA 440 [26] codes. Nowadays, there is a wide range of NSPA and TDA. In case of certain analyses, calculation of target displacement is directly conducted through NSPA (integrated solution), while in other analyses, this is conducted independently (successive solution). In the second case, it is possible to combine solutions of NSPA and TDA by implementing various approaches. Another important factor which can be taken into consideration in classification of these analyses is type of lateral seismic load. Therefore, three key factors which determine differences in these analyses stand prominent: NSPA type, TDA type and lateral seismic load type. Systematization of NSPA is presented without further detailed classification of these analyses, regarding that for these analyses different types of incremental-iterative algorithms are used. Analyses belonging to this group are [31]:

- Nonlinear Static Conventional Pushover Analysis (NSCPA),
- Nonlinear Static Adaptive Pushover Analysis (NSAPA),
- Modal Pushover Analysis (MPA),
- Multi-Mode Pushover Procedure (MMPP),
- Method of Modal Combinations (MMC),
- Incremental Response Spectrum Analysis (IRSA),
- Performance-Based Plastic Design (PBPD),
- Nonlinear Static Pushover Analysis - Damage Mechanisms-Based Design (NSPA-DMBD).

Figure 5 shows the flowchart of NSA according to calculation procedure. NSCPA is based on the continuous retention of distribution of lateral seismic load through all the phases of incremental-iterative analysis, i.e. from initial linear to final collapse state of the structure [4]. NSAPA is based on the correction of lateral seismic load by increments, taking into consideration variation of periods of structural vibrations and spectral amplification of seismic forces according to the acceleration response spectrum or correction of displacement according to the displacement response spectrum [3]. Control of incremental concept for NSCPA and NSAPA is possible via forces as *Force-Based Analysis* (FBA) or via displacements as *Displacement-Based Analysis* (DBA). Depending on how correction of lateral applied forces is conducted, the following options are possible: total (TU), incremental (IU) and hybrid (HU) correction. Depending on the applied control and correction, the results with various degree of accuracy are obtained, where application of incremental displacement concept is especially emphasized.

kontrole i korekcije, dobijaju se rezultati s manjim ili većim stepenom tačnosti, gde se posebno naglašava primena inkrementalnog koncepta pomeranja.

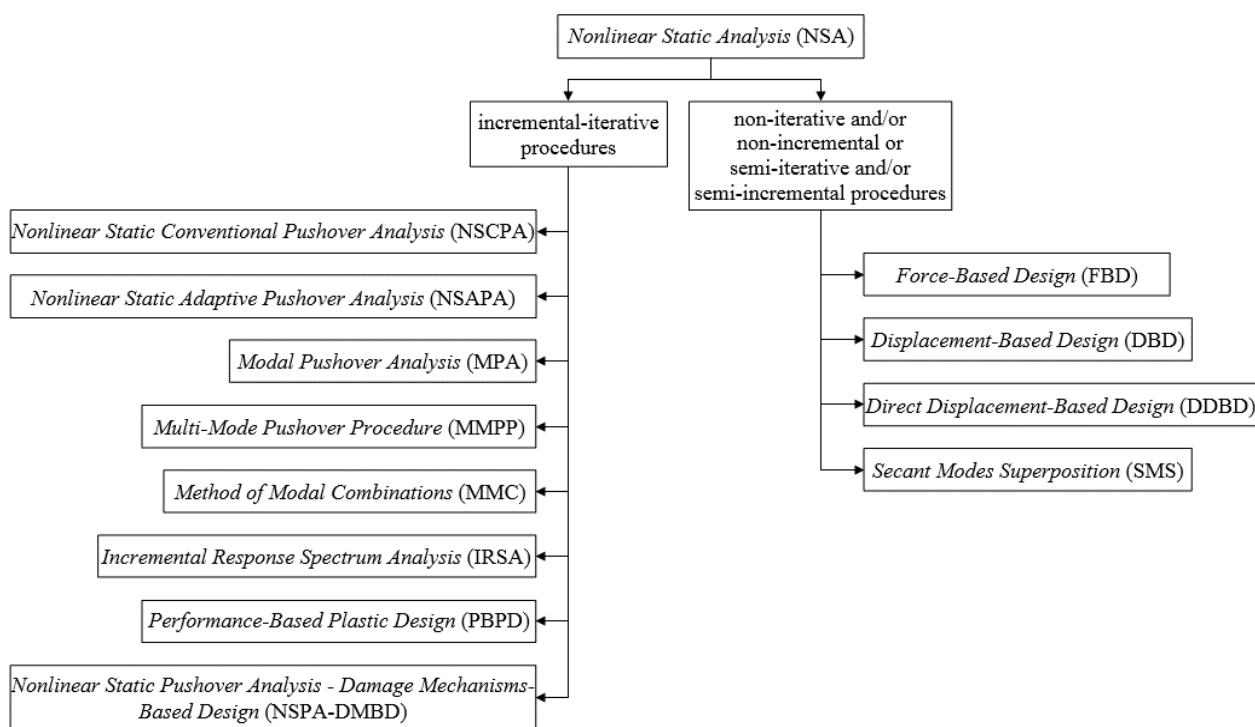

Slika 5. Podela NSA prema postupku proračuna [31]
Figure 5. Flowchart of NSA according to the calculation procedure[31]

Kod MPA se *pushover* krive mogu razviti po svojstvenim oblicima ili se kombinovati i dobiti konačna rešenja za veći broj svojstvenih oblika transformacijom u bilinearne krive ekvivalentnog sistema s jednim stepenom slobode, radi proračuna ciljnog pomeranja i parametara odgovora [13]. MMPP [40] i MMC [34], takođe, koriste različite principe za kombinacije uticaja svojstvenih oblika u ukupnom odgovoru sistema izraženo preko *pushover* krivih, gde se, pored standardnih, izdvajaju kombinacije direktnih superpozicija, efektivna modalna superpozicija i slično. IRSA u osnovi koristi SMA i pravilo jednakosti pomeranja, s tim što se ukupan odgovor sistema dobija primenom *pushover* krive [8]. U matematičkom smislu ova analiza se može razmatrati kao adaptivna multimodalna *pushover* analiza, u kojoj se simultano izvršavaju MPA za svaki svojstveni oblik, za odgovarajuće skalirano modalno pomeranje praćeno odgovarajućim pravilom za kombinovanje svojstvenih oblika. Prema PBPD se, za performansna stanja na nivou cele zgrade, koristi unapred odabrani drift ciljnog pomeranja i mehanizam plastifikacije pri tečenju [38]. Projektna ukupna smičuća sila u osnovi objekta, za odabrani nivo seizmičkog hazarda, dobija se iz proračuna odnosa količine ukupnog rada potrebnog da se konstrukcija dovede do nivoa ciljnog pomeranja i odgovarajuće zahtevane energije ekvivalentnog SDOF sistema. NSPA-DMBD nastala je povezivanjem NSPA, metode programiranog ponašanja (CDM – *Capacity Design Method*) i analize mehanizama loma (DMBD – *Damage Mechanisms-Based Design*) [17]. NSPA-

In MPA, pushover curves can be evolved according to eigenforms or they can be combined and final solutions for a large number of eigenforms can be obtained by transformation into bilinear curves of the SDOF, for the purpose of calculation of target displacement and response parameters [13]. MMPP [40] and MMC [34], too, utilize different principles for combinations of actions of eigenforms in the total response of the system, expressed via pushover, where, in addition to the standard ones, combinations of direct superpositions, effective modal superposition and similar stand prominent. IRSA basically uses SMA and the rule of equivalent displacement, whereby the total response of the system is obtained through implementation of the pushover curve [8]. In mathematical sense, this analysis can be considered as adaptive multimodal pushover analysis, in which modal pushover analyses are simultaneously performed for each eigenform for corresponding scaled modal displacement followed by the corresponding rule for combining of eigenforms. According to PBPD method, for performance states at the level of the entire building, a drift of target displacement chosen in advance, and yield plastic mechanism are used [38]. Design of the total shearing force at the ground level of the structure, for the chosen level of seismic hazard, is obtained from the calculation of the amount of total work required to bring the structure to the target displacement level and corresponding required energy of equivalent SDOF system. NSPA-DMBD method came into being by bringing together NSPA, Capacity Design Method (CDM) and Damage

DMBD pripada grupi metoda iterativno-interaktivnog dimenzionisanja (IID – *Iterative-Interactive Design*), s obzirom na to što se postupak analize mehanizma loma sistema sprovodi iterativno, a dimenzionisanje proverava nakon dostignute granične dilatacije.

NSA analize koje se zasnivaju na neiterativnim i/ili neinkrementalnim postupcima ili primenjuju poluiterativne i/ili poluinkrementalne postupke jesu:

- projektovanje prema silama (FBD - *Force-Based Design*);
- projektovanje prema pomeranju (DBD – *Displacement-Based Design*);
- projektovanje prema pomeranju bez iteracija (DDBD – *Direct Displacement-Based Design*);
- metoda sekantne superpozicije (SMS – *Secant Modes Superposition*).

Ove analize koriste i izraze formulisane iz velikog broja numeričkih testova, eksperimentalnih istraživanja i statističkih obrada podataka, primenom regresionih analiza, tako da u literaturi postoji velik broj gotovih rešenja, algoritama i analitičkih postupaka. Primenom ovih analiza moguće je još u fazi konceptualnog projektovanja konstrukcija obuhvatiti njihovo nelinearno ponašanje, ne ulazeći u detaljnije aspekte numeričkog modeliranja i kompleksne numeričke proračune. Fundamentalna razlika između FBD i DBD jeste što se kod prvih rešenje dobija izlazeći od sila, a kod drugih od pomeranja. DDBD koristi direktan pristup za dobijanje konačnog rešenja, pri čemu se, putem analitičkih postupaka, odgovor sistema dobija kroz elastoplastične modele ponašanja, uspostavljajući relaciju između prigušenja – duktilnosti i pomeranja – perioda vibracija [45]. SMS je razvijena radi dobijanja brzog i dovoljno pouzdanog nelinearnog odgovora sistema za dejstvo zemljotresa, ne uzimajući u obzir direktno NSPA i NDA, ali bazirajući se na sekantnoj krutosti i indeksima odgovora sistema [44]. Rešenje se dobija direktno, za razliku od metoda kod kojih se rešenje dobija po principu *korak po korak*.

TDA, kao što je već rečeno, predstavlja drugi deo NSA analize. Do sada je razvijen veći broj ovih analiza, među kojima su se, za potrebe naučnih istraživanja i stručnih projekata, ustalile:

- metoda spektra kapaciteta (CSM – *Capacity Spectrum Method*);
- neiterativna metoda spektra kapaciteta (NICSM – *Non-Iterative Capacity Spectrum Method*);
- poboljšana metoda spektra kapaciteta (ICSM – *Improved Capacity Spectrum Method*);
- adaptivna metoda spektra kapaciteta (ACSM – *Adaptive Capacity Spectrum Method*);
- metoda koeficijenata pomeranja (DCM – *Displacement Coefficient Method*);
- iterativna metoda koeficijenata pomeranja (IDCM – *Iterative Displacement Coefficient Method*);
- metoda ekvivalentne linearizacije (ELM – *Equivalent Linearization Method*);
- metoda modifikacije pomeranja (DMM – *Displacement Modification Method*);
- N2 metoda (*N2 Method*);
- inkrementalna N2 metoda (IN2 – *Incremental N2 Method*);
- metoda spektra granice tečenja (YPS – *Yield Point Spectra*).

Mechanisms-Based Design (DMBD) [17]. NSPA-DMBD method belongs to the group of Iterative-Interactive Design (IID) methods, regarding that the procedure of analysis of system failure mechanism is conducted iteratively, and dimensioning is verified when the ultimate strains have been reached.

NSA analyses based on the non-iterative and/or non-incremental procedures or implementing semi-iterative and/or semi-incremental procedures are:

- Force-Based Design (FBD),
- Displacement-Based Design (DBD),
- Direct Displacement-Based Design (DDBD),
- Secant Modes Superposition (SMS).

These analyses utilize expressions formulated from a large number of numerical tests, experimental research and statistic data processing, through implementation of regression analyses, so that in literature there is lots of ready-made solutions, algorithm and analytical procedures. By implementing these analyses, it is possible as early as in the phase of conceptual design of structures to include its nonlinear behaviour, without venturing into the more detailed aspects of numerical modelling and complex numerical calculations. Fundamental difference between FBD and DBD analyses is that in the former ones, the solution is obtained using forces as an initial parameter, and in latter ones the displacement parameter is used. DDBD analyses use a direct approach for obtaining the final solution, whereby, through analytical procedures, the response of the system is obtained via elastoplastic behaviour models, by establishing a relation between the damping - ductility and displacement - period of vibrations [43]. SMS analysis is developed with the purpose of obtaining a rapid and sufficiently reliable nonlinear response of the system to earthquake actions, without directly taking into account NSPA and NDA, but basing itself on the secant stiffness and indices of system response [44]. Solution is obtained directly in contrast to the methods where the solution is found *step by step*.

It was presented that TDA represents a second part of NSA analysis. Until now, a large number of these analyses were developed for the purposes of scientific research and professional designs, among which the following are the most common ones:

- Capacity Spectrum Method (CSM),
- Non-Iterative Capacity Spectrum Method (NICSM),
- Improved Capacity Spectrum Method (ICSM),
- Adaptive Capacity Spectrum Method (ACSM),
- Displacement Coefficient Method (DCM),
- Iterative Displacement Coefficient Method (IDCM),
- Equivalent Linearization Method (ELM),
- Displacement Modification Method (DMM),
- N2 Method,
- Incremental N2 Method (IN2),
- Yield Point Spectra (YPS).

Na slici 6 je prikazana podela NSA – TDA prema postupku proračuna.

Figure 6 shows the flowchart of NSA - TDA according to the calculation procedure.

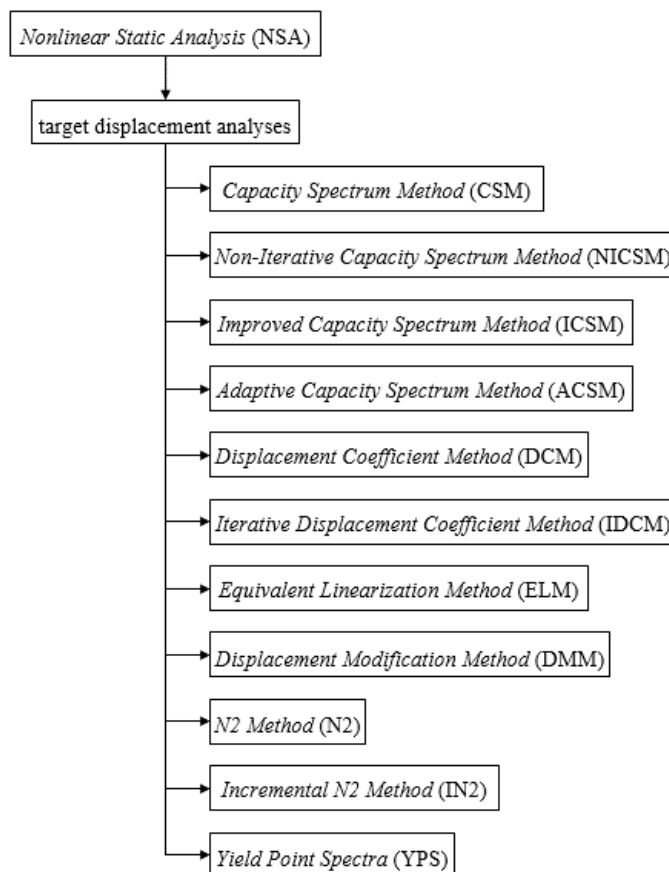

Slika 6. Podela NSA -TDA prema postupku proračuna [31]
 Figure 6. Flowchart of NSA - TDA according to the calculation procedure[31]

CSM pripada grupi analiza kojom se sprovodi samo TDA iz odnosa krive kapaciteta, krive seizmičkog zahteva i spektra odgovora [6], [32]. Razvijeno je nekoliko tipova CSM koje koriste spektralni odgovor u formatu spektralno ubrzanje - spektralno pomeranje (ADRS - *acceleration-displacement response spectra*), pri čemu je postupak određivanja nivoa ciljnog pomeranja iterativan. Ova metoda je implementirana u ATC 40 propise [6]. Kod NICSM se direktno određuje nivoo ciljnog pomeranja, bez iteracija, bazirajući se na rešenjima ekvivalentnih linearnih metoda [55]. Takođe, ovoj grupi pripadaju ICSM [54], [33] i ACSM [11], [10] koje su zapravo poboljšane verzije postojeće CSM i koje primenjuju statistički optimizovane linearizovane parametre i adaptivne algoritme za određivanje nivoa ciljnog pomeranja. Primenom DCM sprovodi se samo TDA, koristeći princip multiplikacije grupe koeficijenata kojima se uzima u obzir uticaj različitih faktora ponašanja konstrukcija. Ova metoda je implementirana u FEMA 356 propise [25]. U IDCM implementiran je dvostruki iterativni algoritam koji se sukcesivno sprovodi, a rešenje nivoa ciljnog pomeranja se, između ostalog, pretražuje i po *pushover* krivi [16]. IDCM u osnovi koristi matematičku formulaciju DCM, s tim što je kroz iterativni algoritam znatno unapređeno rešenje dobijanja ciljnog pomeranja. ELM je zapravo novija generacija CSM

CSM belongs to a group of analyses which conduct only TDA from the relations of capacity curve, seismic demand curve and response spectrum [6], [32]. Several types of CSM methods were developed, which use response spectrum in the format spectral acceleration - spectral displacement (ADRS), whereby the procedure of determining target displacement level is iterative. This method is implemented in ATC 40 codes [6]. NICSM directly determines the level of target displacement, without iterations, basing on the solutions of equivalent linear methods [55]. This group also includes ICSM [54], [33] and ACSM [11], [10] which are actually improved versions of the existing CSM and which implement statistically optimized linearized parameters and adaptive algorithms for determination of target displacement level. By implementing DCM only TDA is conducted, employing the principle of multiplication of a group of coefficients which takes into account influence of various factors of structural behaviour. This method is implemented in FEMA 356 codes [25]. In IDCM, successively conducted double iterative algorithm is implemented and the solution of target displacement level is, among other things, searched for using a pushover curve [16]. IDCM basically used mathematical formulation of DCM, whereby, through an iterative algorithm, the solution of target displacement is

implementirana u FEMA 440 propise [26], gde se, umesto spektra odgovora u ADRS formatu, koristi modifikovan spektar odgovora (MADRS - *modified acceleration-displacement response spectra*). DMM je, takođe, novija generacija DCM, gde su eliminisani određeni koeficijenti koji participiraju u proračunu, a dodatno su unapređeni delovi proračuna koji se odnose na histerezisne modele ponašanja konstrukcija. Ova metoda je implementirana u FEMA 440 propise [26]. TDA prema N2, implementirana u EN 1998-1:2004 [23] propis, proračunava se uzimajući u obzir neelastični spektar odgovora u funkciji koeficijenta duktilnosti [24]. Proširenje N2 predstavljeno je u formi IN2, kod koje je, osim prezentacije EDP parametara na abscisi i ordinati, moguće koristiti mere intenziteta (IM - *intensity measure*) na ordinati [21]. Na taj način, primenom IN2 može se direktno sprovesti komparacija rešenja sa inkrementalnom dinamičkom analizom (IDA - *Incremental Dynamic Analysis*). Nova spektralna prezentacija seizmičkog zahteva prikazana je YPS metodom, gde je zadržana osnova CSM i NSPA [5]. YPS metoda se može koristiti za projektovanje novih i ojačanje postojećih konstrukcija za odgovarajuće zahtevane nivoe krutosti i nosivosti, uz dodatno ograničenje globalne duktilnosti i drifta.

Kod NSA, odnosno NSPA prigušenje se ne uvodi pre proračuna, već se naknadno definiše nakon proračuna konstrukcije u TDA. Na slici 7 je prikazan dijagram toka uvođenja prigušenja kod NSPA.

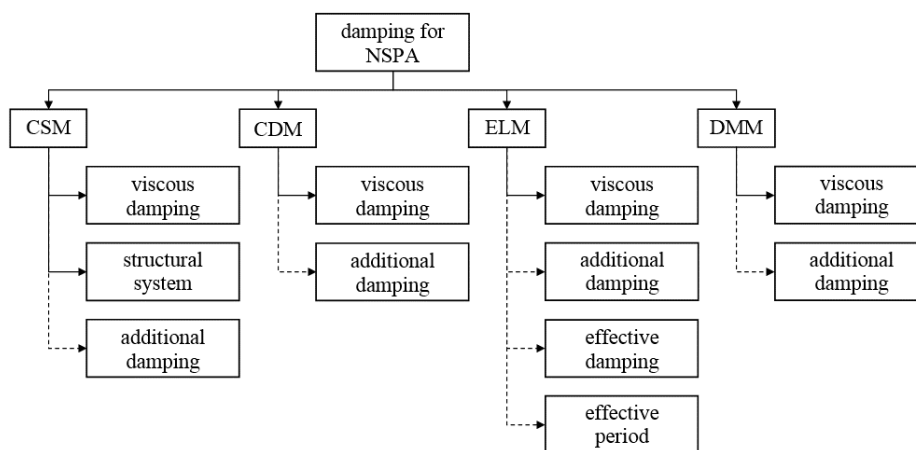

Slika 7. Dijagram toka uvođenja prigušenja kod NSPA [30]
Figure 7. Flowchart of introducing damping into NSPA [30]

Postupak uvođenja prigušenja sprovodi se preko jednog globalnog koeficijenta kojim se može uzeti u obzir i viskozno i histerezisno prigušenje. U zavisnosti od tipa analize ciljnog pomeranja moguće su opcije:

– CSM:

Prigušenje se uvodi preko globalnog koeficijenta prigušenja kao osnovno (*inherent*) i dodatno (*additional*) prigušenje, ali se može dodatno uticati i preko tipa konstruktivnog sistema. Za nivo ciljnog pomeranja d_t , koji se određuje kroz iteracije, ukupno efektivno prigušenje u sistemu ξ_{eff} dobija se prema [6]:

considerably improved. ELM is actually a new generation of CSM implemented in FEMA 440 codes [24], where instead of a response spectrum in ADRS format, modified response spectrum is utilized in the format spectral acceleration - spectral displacement (MADRS). DMM is, also, a newer generation of DCM, where certain coefficients participating in calculation were eliminated, while parts of calculation related to hysteretic models of structural behaviour were additionally improved. This method was implemented in FEMA 440 codes [26]. TDA according to N2 method, implemented in EN 1998-1:2004 [23] code is determined by taking into consideration the inelastic response spectrum in function of ductility coefficient [24]. Extension of N2 method is presented in the form of IN2 method, where, except of presentation of EDP parameters on abscissa and ordinate, it is possible to use intensity measure (IM) on ordinate [21]. In this way IN2 method can directly compare solutions with *Incremental Dynamic Analysis* (IDA). New spectral presentation of seismic demand is presented by YPS method, in which the basis of CSM and NSPA was retained [5]. YPS method can be used for designing new and strengthening existing structures for the required levels of stiffness and bearing capacity, with the additional limitation of global ductility and drift.

In NSA or NSPA damping is unlikely to be introduced before calculation; instead, it is subsequently defined after the structure is calculated in TDA. Figure 7 shows the flowchart of introducing damping into NSPA.

Damping is introduced through a global coefficient which can take into account both viscous and hysteretic damping. Depending on the type of TDA, the following options are possible:

– CSM:

Damping is introduced through a global damping coefficient as inherent and additional damping, but it can also be affected through the type of structural system. For the level of target displacement d_t , which is determined by iterations, the overall effective damping in the system ξ_{eff} is obtained from [6]:

$$\zeta_{eff} = \kappa \zeta_h + \zeta_v = \frac{63.7 \kappa (S_{a,y} S_{d,t} + S_{d,y} S_{a,t})}{S_{a,t} S_{d,t}} + \zeta_v, \quad (17)$$

gde je ζ_v koeficijent relativnog (viskozno) prigušenja (5%), ζ_h koeficijent histerezisnog prigušenja (prikazan kao ekvivalentno viskozno prigušenje), $S_{a,y}$ spektralna akceleracija na granici tečenja prikazana u ADRS, $S_{a,t}$ spektralna akceleracija za nivo ciljnog pomeranja, $S_{d,y}$ spektralno pomeranje na granici tečenja, $S_{d,t}$ spektralno pomeranje za nivo ciljnog pomeranja, κ koeficijent kojim se uzima u obzir koliko dobro je histerezisni model konstrukcije aproksimiran bilinearnim histerezisnim modelom.

– CDM:

Prigušenje se uvodi preko koeficijenta efektivnog prigušenja, a koji se koristi pri generisanju spektra odgovora. U suštini, ovo je viskozno prigušenje, dok se histerezisno određuje iz proračuna, mada se može uvesti i dodatno prigušenje preko ovog koeficijenta [25].

– ELM:

Prigušenje se uvodi preko globalnog koeficijenta prigušenja (osnovno i dodatno prigušenje), ali se kao alternativa može definisati efektivno prigušenje, prikazano preko koeficijenta relativnog prigušenja za histerezisni odgovor sistema [26]:

where ζ_v is the relative (viscous) damping coefficient (5%), ζ_h is the hysteretic damping coefficient (shown as equivalent viscous damping), $S_{a,y}$ is spectral acceleration at the yield point shown in the ADRS format, $S_{a,t}$ is spectral acceleration for the level of target displacement, $S_{d,y}$ is spectral displacement at the yield point, $S_{d,t}$ is spectral displacement for the level of target displacement, κ is the coefficient that takes into account how well the structure's hysteretic model is approximated by the bilinear hysteretic model.

– CDM:

Damping is introduced through the effective damping coefficient which is used in generating the response spectrum. In fact, this is a viscous damping, while a hysteretic damping is determined from calculation, but additional damping may also be introduced over this coefficient [25].

– ELM:

Damping is introduced through the global damping coefficient (basic and additional damping), but effective damping can be defined as an alternative solution, shown through the relative damping coefficient for the system's hysteretic response [26]:

$$\begin{aligned} 1 < \mu < 4 : & \quad \zeta_{eff} = A(\mu - 1)^2 + B(\mu - 1)^3 + \zeta_h \\ 4 \leq \mu \leq 6.5 : & \quad \zeta_{eff} = C + D(\mu - 1) + \zeta_h \\ \mu > 6.5 : & \quad \zeta_{eff} = E \left(\frac{F(\mu - 1) - 1}{(F(\mu - 1))^2} \right) \left(\frac{T_{eff}}{T_0} \right)^2 + \zeta_h \end{aligned}, \quad (18)$$

gde su vrednosti za A, B, C, D, E, F date u [26], dok se efektivan period vibracija određuje prema:

where values of A, B, C, D, E, F are given in [26], while the effective period of vibrations is determined by:

$$\begin{aligned} 1 < \mu < 4 : & \quad T_{eff} = (G(\mu - 1)^2 + H(\mu - 1)^3 + 1) T_0 \\ 4 \leq \mu \leq 6.5 : & \quad T_{eff} = (I + J(\mu - 1) + 1) T_0 \\ \mu > 6.5 : & \quad T_{eff} = \left(K \left(\sqrt{\frac{(\mu - 1)}{1 + L(\mu - 2)}} - 1 \right) + 1 \right) T_0 \end{aligned}, \quad (19)$$

gde su vrednosti za G, H, I, J, K, L date u [26], dok je T_0 inicijalan period vibracija nelinearnog sistema.

– DMM:

Prigušenje se uvodi preko koeficijenta efektivnog prigušenja, a koji se koristi pri generisanju spektra odgovora. U suštini, ovo je viskozno prigušenje, dok se histerezisno određuje iz proračuna, mada se može uvesti i dodatno prigušenje preko ovog koeficijenta [26].

where values for G, H, I, J, K, L are given in [26], while T_0 is the initial period of vibrations of the nonlinear system.

– DMM:

Damping is introduced through the effective damping coefficient, which is used in generating the response spectrum. Essentially, this is a viscous damping, while a hysteretic is determined from calculation, but additional damping may also be introduced over this coefficient [26].

5 LINEARNA DINAMIČKA ANALIZA (LDA)

Linearna dinamička analiza (LDA – *Linear Dynamic Analysis*) sprovodi se u vremenskom domenu, tako što se za ulazni seizmički signal koristi akcelerogram prirodnog ili veštačkog zemljotresa. Na ordinati vremenskog domena se predstavljaju EDP i IM kao

5 LINEAR DYNAMIC ANALYSIS (LDA)

LDA is conducted in time domain with accelerogram of natural or artificial earthquake used as the input seismic signal. The ordinate of time domain presents the EDP and IM as time dependent variables. Using LDA direct solution is obtained for the level of target

promenljive u vremenu. Primenom LDA se dobija direktno rešenje za nivo ciljnog pomeranja, tako da je ovo ujedno i TDA. Akcelerogram se skalira i/ili kompatibilizuje prema projektnom spektru odgovora iz propisa ili se koristi reprezentativan spektar odgovora grupe akcelerograma, pa se on naknadno skalira i/ili kompatibilizuje prema projektnom spektru odgovora iz propisa.

Uvođenje prigušenja u modalnu LDA moguće je sprovesti primenom: prigušenja materijala, prigušenja elemenata veze i prigušenja u analizi. Na slici 8 je prikazan dijagram toka uvođenja prigušenja kod modalne LDA. Prigušenje materijala se uvodi kao modalno prigušenje, dok se prigušenje elemenata veze uvodi kao efektivno prigušenje. Prigušenje koje se direktno definiše u analizi uvodi se kao: konstantno prigušenje, interpolirano prigušenje i primenom faktora participacije mase i krutosti, pri čemu se ovo poslednje prigušenje može uvesti primenom: faktora participacije mase i krutosti α i β , u funkciji perioda vibracija prvog i drugog svojstvenog oblika T_1 i T_2 i u funkciji frekvencija prvog i drugog svojstvenog oblika f_1 i f_2 .

displacement, so this is TDA in the same time. The accelerogram is scaled and/or made compatible according to the spectrum response under terms of regulations, or a representative response spectrum is used from the accelerogram group, which is later scaled and/or made compatible based on the project response spectrum provided in regulations.

Damping in modal LDA can be introduced by using: material damping, link element damping and damping in the analysis. Figure 8 shows the flowchart of damping introduction into modal LDA. Material damping is introduced as modal damping, while the link element damping is introduced as effective damping. Damping that is directly defined in the analysis is introduced as: constant damping, interpolated damping, and using the factors of mass and stiffness participation, whereby the latter can be introduced using: factors of mass and stiffness (α and β) participation as function of vibration period and frequency.

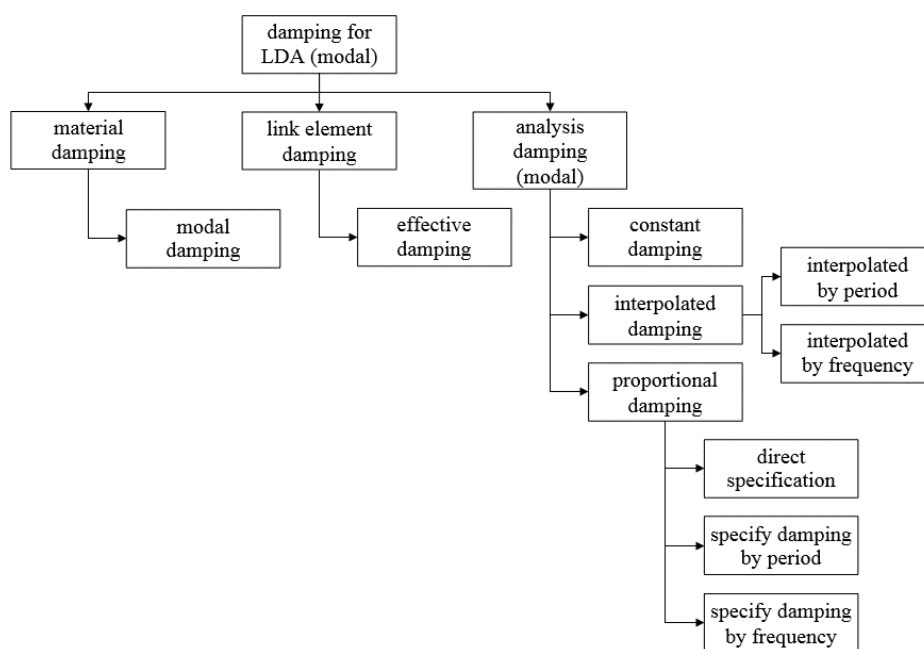

Slika 8. Dijagram toka uvođenja prigušenja kod modalne LDA [30]
Figure 8. Flowchart of introducing damping into modal LDA [30]

Diferencijalne jednačine kretanja sistema sa više stepeni slobode, kod modalne LDA, formulišu se u matricnom obliku [52]:

$$[M]\{\ddot{u}\} + [C]\{\dot{u}\} + [K]\{u\} = \{F\}, \quad (20)$$

gde je $[M]$ matrica masa, $[K]$ matrica krutosti, $\{\ddot{u}\}$ vektor ubrzanja, $\{\dot{u}\}$ vektor brzine, $\{u\}$ vektor pomeranja konstrukcije, $\{F\}$ vektor spoljašnjeg opterećenja. Prilikom proračuna modalne LDA formira se matrica prigušenja prema izrazu (20), a u zavisnosti od tipa prigušenja koje je definisano pre izvršenja analize.

Uvođenje prigušenja u LDA (numerička integracija) moguće je sprovesti primenom: prigušenja materijala,

Differential equations of movement of systems with several degrees of freedom, such as modal LDA, are formulated in matrix form [52]:

where $[M]$ is the mass matrix, $[K]$ the stiffness matrix, $\{\ddot{u}\}$ the acceleration vector, $\{\dot{u}\}$ the velocity vector, $\{u\}$ the structural displacement vector, and $\{F\}$ the external load vector. When calculating the modal LDA, the damping matrix is formed according to the expression (20), and depending on the type of damping which is defined prior to execution of the analysis.

In numerical integration LDA damping can be introduced by using: material damping, link element

prigušenja elemenata veze i prigušenja u analizi. Na slici 9 je prikazan dijagram toka uvođenja prigušenja kod LDA (numerička integracija).

damping and damping in the analysis. Figure 9 shows the flowchart of damping introduction into numerical integration LDA.

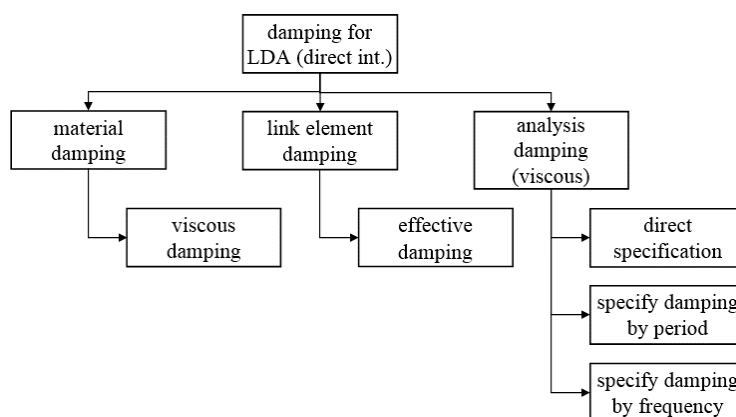

Slika 9. Dijagram toka uvođenja prigušenja kod LDA (numerička integracija) [30]
Figure 9. Flowchart of introducing damping into numerical integration LDA [30]

Prigušenje materijala se uvodi kao viskozno prigušenje, dok se prigušenje elemenata veze uvodi kao efektivno prigušenje. Prigušenje koje se direktno definiše u analizi uvodi se primenom: faktora participacije mase i krutosti α i β , u funkciji perioda vibracija prvog i drugog svojstvenog oblika T_1 i T_2 i u funkciji frekvencija prvog i drugog svojstvenog oblika f_1 i f_2 . Diferencijalne jednačine kretanja sistema sa više stepeni slobode, kod LDA (numerička integracija), formulišu se u matricnom obliku [52]:

$$[M]\{\Delta\ddot{u}\} + [C]\{\Delta\dot{u}\} + [K]\{\Delta u\} = \{\Delta F\}, \quad (21)$$

gde je $\{\Delta u\}$ vektor inkrementa ubrzanja, $\{\Delta\dot{u}\}$ vektor inkrementa brzine, $\{\Delta u\}$ vektor inkrementa pomeranja konstrukcije, $\{\Delta F\}$ inkrement vektora spoljašnjeg opterećenja. Prilikom proračuna LDA (numerička integracija) formira se matrica prigušenja prema izrazu (21), a u zavisnosti od tipa prigušenja koje je definisano pre izvršenja analize.

Material damping is introduced as viscous damping, while the link element damping is introduced as effective damping. Damping that is directly defined in the analysis is introduced by using: the factors mass and stiffness participation (α and β) as a function of the vibration period and a function of frequency. In numerical integration LDA, differential equations of the movement of system with several degrees of freedom are formulated in matrix form [52]:

where $\{\Delta\ddot{u}\}$ is the acceleration increment vector, $\{\Delta\dot{u}\}$ the speed increment vector, $\{\Delta u\}$ the vector of structural displacement increment, and $\{\Delta F\}$ is the vector of external load increment. When calculating the numerical integration LDA, a damping matrix is formed according to expression (21) as a function of the type of damping which is defined prior to the execution of the analysis.

6 NELINEARNA DINAMIČKA ANALIZA (NDA)

U odnosu na rešenja koja se dobijaju u kapacitativnom domenu primenom NSA, kod NDA rešenja se dobijaju u vremenskom domenu. Proračun nelinearnog odgovora se sprovodi primenom numeričke integracije, pri čemu se najčešće primenjuje *Newmark-ova* metoda prosečnog ubrzanja (AAM – *Average Acceleration Method*) ili metoda linearnog ubrzanja (LAM – *Linear Acceleration Method*), a takođe, primenjuje se i *Wilson-ov*, *Hilber-Hughes-Taylor-ov* i *Chung-Hulbert-ov* postupak. Najtačnije metode za analizu seizmičkog odgovora sistema jesu NDA analize, ukoliko se uzima u obzir potpun razvoj materijalne nelinearnosti, plastičnim zglobovima ili propagacijom neelastičnih deformacija primenom vlakana, i geometrijske nelinearnosti, kada se u analizi uzimaju u obzir velike deformacije i pomeranja. U ove analize se ubrajaju:

- nelinearna dinamička analiza zasnovana na modalnoj i numeričkoj integraciji (NDA – *Nonlinear*

6 NONLINEAR DYNAMIC ANALYSIS (NDA)

In comparison with the solutions obtained in the capacitive domain using NSA, in NDA solutions are obtained in time domain. Nonlinear response calculation is conducted by implementing numerical integration, whereby the most frequently implemented is *Newmark Average Acceleration Method* (AAM) or *Newmark Linear Acceleration Method* (LAM), along with the procedures by *Wilson*, *Hilber-Hughes-Taylor* and *Chung-Hulbert*. The most accurate methods for seismic response analysis are NDA, if considering full development of material nonlinearity through plastic hinges or propagation of inelastic deformations by using fibres, and geometrical nonlinearities when the analysis takes into account large deformations and displacements. These analyses include:

- modal and numerical integration *Nonlinear Dynamic Analysis* (NDA),
- *Endurance Time Method* (ETM).

Dynamic Analysis);

– metod vremena izdržljivosti (ETM – *Endurance Time Method*).

Na slici 10 je prikazana podela NDA prema postupku proračuna [31].

Figure 10 shows the NDA flowchart according to the calculation procedure [31].

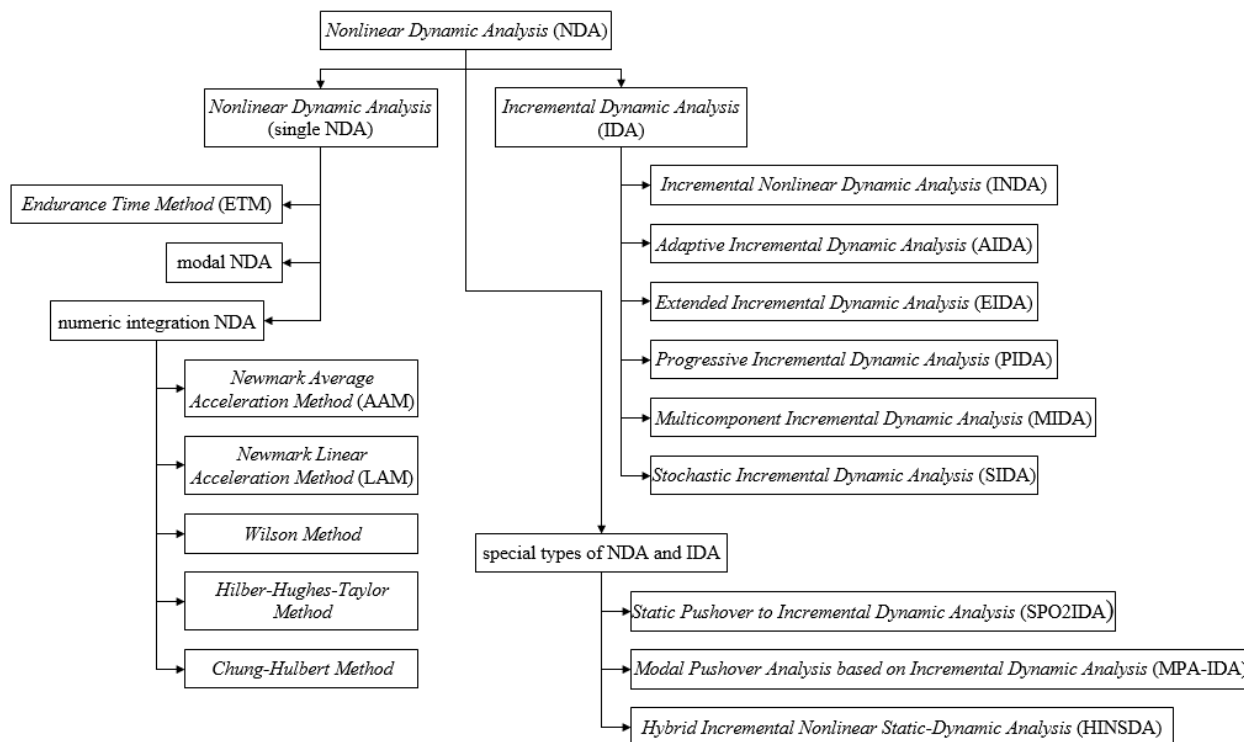

Slika 10. Podela NDA prema postupku proračuna [31]
Figure 10. NDA flowchart according to the calculation procedure[31]

Primenom NDA dobija se, kao što je već rečeno, odgovor sistema u vremenskom domenu, ali za samo jedan nivo seizmičkog zahteva. S druge strane, primenom ETM dobija se odgovor sistema u vremenskom domenu s kontinualnim priraštajem nelinearnih deformacija, od inicijalnog elastičnog do kolapsnog stanja [7]. Specifičnost ove metode ogleda se u primeni posebno konstruisane funkcije pobude – akceleroograma koji je, između ostalog, dodano kompatibilizovan prema spektru odgovora i optimizovan za nelinearan odgovor sistema.

Ukoliko se primeni set NDA sukcesivno povećavajući faktor skaliranja akceleroograma, tada se konačno rešenje može dobiti u kapacitativnom domenu. U tom smislu je veoma povoljno sprovoditi komparaciju rešenja dobijenih NSA i IDA. Faktički, rešenje dobijeno iz seta NDA u vremenskom domenu transformiše se u kapacitativan domen. Ovo se sprovodi tako što se izdvajaju ekstremne i odgovarajuće diskretne vrednosti, koje se zatim interpoliraju splajn funkcijom. Analize koje pripadaju ovoj grupi jesu [31]:

- inkrementalna dinamička analiza (IDA – *Incremental Dynamic Analysis*);
- inkrementalna nelinearna dinamička analiza (INDA – *Incremental Nonlinear Dynamic Analysis*);
- adaptivna inkrementalna dinamička analiza (AIDA – *Adaptive Incremental Dynamic Analysis*);

As already mentioned, a system response in time domain is obtained by implementing NDA, but only for one level of seismic demand. On the other hand, implementation of ETM provides system response in time domain with continuous increase of nonlinear deformations, from initially elastic to collapse state [7]. Singularity of this method reflects in implementation of specially designed excitation function (accelerogram) which is, inter alia, additionally compatible with the response spectrum and optimized for nonlinear system response.

If a set of NDA is implemented while successively increasing scaling factor of the accelerogram, then the final solution is obtained in capacitive domain. Thus, it is favourable to conduct comparison of solutions obtained by NSA and IDA. Actually, solution obtained from a set of NDA in time domain is transformed into capacitive domain. This is performed by singling out extreme and corresponding discrete values which are then interpolated by spline functions. Analyses belonging to this group are [31]:

- Incremental Dynamic Analysis (IDA),
- Incremental Nonlinear Dynamic Analysis (INDA),
- Adaptive Incremental Dynamic Analysis (AIDA),
- Extended Incremental Dynamic Analysis (EIDA),
- Progressive Incremental Dynamic Analysis (PIDA),

- proširena inkrementalna dinamička analiza (EIDA – *Extended Incremental Dynamic Analysis*);
- progresivna inkrementalna dinamička analiza (PIDA – *Progressive Incremental Dynamic Analysis*);
- multikomponentalna inkrementalna dinamička analiza (MIDA – *Multicomponent Incremental Dynamic Analysis*);
- stohastička inkrementalna dinamička analiza (SIDA – *Stochastic Incremental Dynamic Analysis*).

Termin IDA već je ustaljen u naučnim istraživanjima [51], dok je termin INDA prvi put uveden u [18] i ove analize se odnose na set NDA kod kojih se akcelerogram sukcesivno skalira, pri čemu je konstrukcija modelirana tako da najbolje opisuje realan fizički model konstrukcije i gde je uveden razvoj potpune materijalne i geometrijske nelinearnosti. AIDA se zasniva na adaptivnoj promeni selekcije zapisa ubrzanja tla pri različitim intenzitetima kretanja tla [39], dok se kod EIDA uvode neizvesnosti: zavisne od modela konstrukcije (*epistemic uncertainty*) i zavisne od seizmičkog hazarda i selekcije zapisa ubrzanja tla (*aleatoric uncertainty*) [22]. Neizvesnosti zavisne od modela konstrukcije određuju se primenom *Latin Hypercube Sampling* (LHS) metode. PIDA je razvijena kako bi se skratilo vreme potrebno za sprovođenje obimnih IDA, a da se zadrži nivo kvaliteta rešenja [9]. Takođe, slično PIDA, razvijene su MIDA i SIDA, s tim što se prvom analizom može razmatrati nelinearan odgovor sistema za različite uglove dejstva zemljotresa [37], a drugom analizom se stohastičkim modelovanjem, između ostalog, primenom *Point Estimation Method* (PEM) dobija rešenje u domenu kapaciteta [53].

Posebni tipovi NDA koji dobijaju rešenja u kombinaciji s drugim metodama jesu:

- statička *pushover* analiza zasnovana na inkrementalnoj dinamičkoj analizi (SPO2IDA – *Static Pushover to Incremental Dynamic Analysis*);
- modalna *pushover* analiza zasnovana na inkrementalnoj dinamičkoj analizi (MPA-IDA – *Modal Pushover Analysis based on Incremental Dynamic Analysis*);
- hibridna inkrementalna nelinearna statička-dinamička analiza (HINSDA – *Hybrid Incremental Nonlinear Static-Dynamic Analysis*).

SPO2IDA je razvijena u okviru istraživanja [50], a bazira se na primeni NSPA i niza regresionih analiza kojima se simulira IDA odgovora sistema. Na taj način se dobija odgovor sistema u kapacitativnom domenu, pri čemu se na abscisi koriste EDP parametri, a na ordinati IM mere. Kod IDA-MPA seizmički odgovor sistema se određuje iz NDA analize SDOF sistema, koji je ekvivalentan MDOF sistemu [42]. Radi dobijanja bržeg i dovoljno pouzdanog rešenja, u odnosu na INDA, razvijena je potpuno nova procedura nazvana hibridna nelinearna statička-dinamička analiza (HNSDA – *Hybrid Nonlinear Static-Dynamic Analysis*) [18]. U HNSDA analizi se koristi nelinearan odgovor MDOF sistema iz NSPA za proračun na korigovanom SDOF sistemu primenom NDA. Ukoliko se nelinearan odgovor sistema razmatra u kapacitativnom domenu, tada ova analiza postaje hibridna inkrementalna nelinearna statička-dinamička analiza (HINSDA).

Ključni aspekt kod TDA za NDA jeste procesiranje akcelerograma prema teoriji obrade signala. Na slici 11 je prikazana podela NDA – TDA prema postupku

- Multicomponent Incremental Dynamic Analysis (MIDA),
- Stochastic Incremental Dynamic Analysis (SIDA).

The term IDA is already well-established in scientific research [51], while the term INDA was for the first time introduced in [18] and these analyses refer to a set of NDA in which an accelerogram is successively scaled, whereby the structure is modelled to provide the best possible actual physical model of a structure and in which development of complete material and geometric nonlinearity was introduced. AIDA is based on the adaptive variation of selection of ground motion records at different intensities of ground motion [39], while EIDA introduces into the calculation epistemic (depending on the structure model) and aleatoric (depending on the seismic hazard and selection of ground motion records) uncertainties [22]. Epistemic uncertainty is determined by implementing *Latin Hypercube Sampling* (LHS) method. PIDA was developed with an aim of shortening the time necessary for performing of extensive IDA, while retaining the quality level of the solution [9]. Also, similar to PIDA, MIDA and SIDA were developed, whereby the former analysis can analyze a nonlinear system response for different angles of earthquake actions [37], and the latter analysis, through stochastic modelling inter alia, by implementing *Point Estimation Method* (PEM) a solution in capacitive domain is obtained [53].

Special types of NDA which obtain solutions in combination with other methods are:

- Static Pushover to Incremental Dynamic Analysis (SPO2IDA),
- Modal Pushover Analysis based on Incremental Dynamic Analysis (MPA-IDA),
- Hybrid Incremental Nonlinear Static-Dynamic Analysis (HINSDA).

SPO2IDA method is developed in the framework of research [50], and it is based on implementation of NSPA and a number of regression analyses which simulate IDA system response. The obtained system response is located in a capacitive domain, whereby EDP parameters are used on abscissa and IM parameters on ordinate. In the case of IDA-MPA, seismic system response is determined from NDA of SDOF system, which is equivalent to MDOF system [42]. In order to obtain a more rapid and sufficiently reliable solution, in comparison with INDA, a completely new procedure called *Hybrid Nonlinear Static-Dynamic Analysis* (HNSDA) was developed [18]. Nonlinear response to MDOF system is used in HNSDA from NSPA intended for calculation on the corrected SDOF system by implementing NDA. If nonlinear system response is considered in a capacitive domain, then this analysis becomes *Hybrid Incremental Nonlinear Static-Dynamic Analysis* (HINSDA).

The key aspect for TDA, for NDA, is processing of an accelerogram according to signal processing theory. Figure 11 shows the NDA - TDA flowchart according to the calculation procedure [31].

proračuna [31].

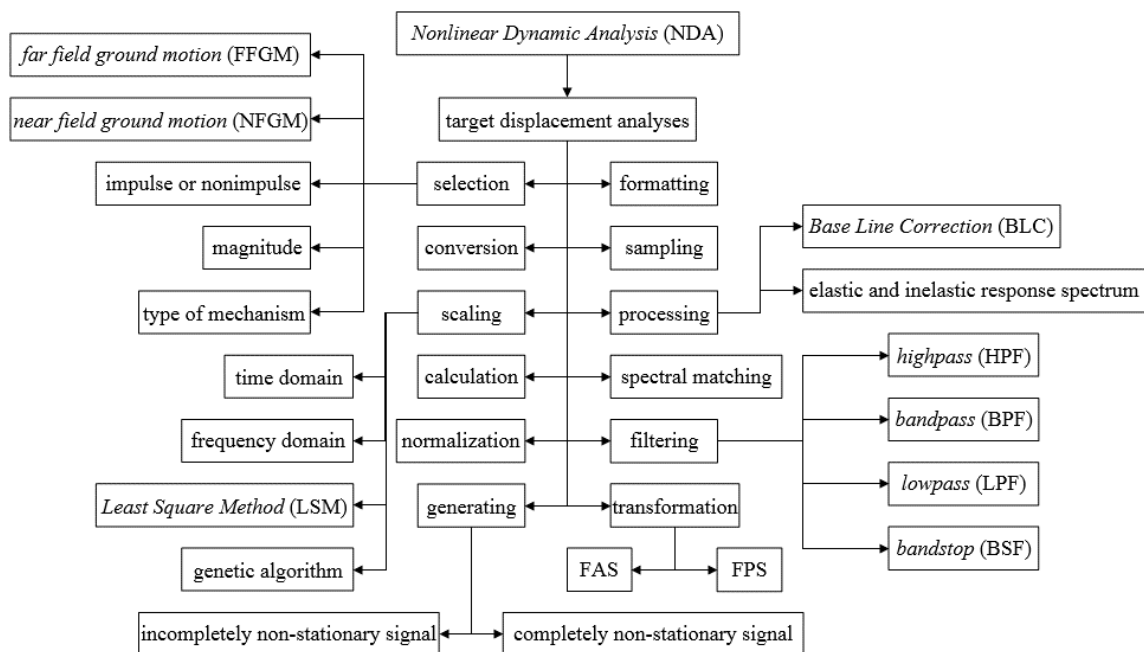

Slika 11. Podela NDA - TDA prema postupku proračuna [31]
 Figure 11. NDA - TDA flowchart according to the calculation procedure[31]

Postupak procesiranja akcelorograma obuhvata analizu, interpretaciju i prezentaciju akcelorograma kroz faze: selekcija, formatiranje, konvertovanje, semplovanje, skaliranje, kalkulacija, procesiranje, kompatibilizacija (*spectral matching*), normalizacija, filtriranje, generisanje i transformacija [15]. Ove procedure se izvršavaju u vremenskom, frekventnom, frekventno-vremenskom i kapacitivnom domenu. Selekcija je procedura odabira određenog tipa zemljotresa ili grupe zemljotresa prema unapred zadatim kriterijumima, kao što je selekcija prema kriterijumima da li su zemljotresi udaljeni (FFGM – *far field ground motion*) ili bliski (NFGM – *near field ground motion*), impulsni ili neimpulsni zemljotresi, prema magnitudi, tipu mehanizma, udaljenosti od mesta iniciranja propagacije seizmičkih talasa, brzini smičućih talasa u tlu za gornjih 30m dubine, hipocentralnom rastojanju ili prema nekom drugom kriterijumu. Formatiranje je procedura transformacije oblika zapisa akcelorograma iz baze zemljotresa i prilagođavanje softveru za analizu konstrukcija, dok je konvertovanje procedura transformacije jednih jedinica mere u druge. Skaliranje je skup procedura kojima se direktno ili indirektno multipliciraju vrednosti ubrzanja akcelorograma prema određenim kriterijumima. Skaliranje akcelorograma se sprovodi primenom nekoliko procedura, od kojih se izdvajaju: skaliranje akcelorograma u vremenskom domenu, skaliranje akcelorograma u frekventnom domenu, skaliranje preko spektra odgovora primenom metode najmanjih kvadrata (LSM – *Least Square Method*), skaliranje preko spektra odgovora primenom genetičkog algoritma, kompatibilizacija (*spectral matching*) i slične procedure. Kalkulacija je skup procedura kojima se određuju bazni parametri akcelorograma, kao što su mere intenziteta (IM), dok je procesiranje skup procedura koje mogu biti različitog karaktera, kao što je korekcija bazne linije (BLC – *Base*

The accelerogram processing procedure includes analysis, interpretation and presentation of accelerogram through the phases: selection, formatting, conversion, sampling, scaling, calculation, processing, spectral matching, normalization, filtering, generating and transformation [15]. These procedures are executed in time, frequency, frequency-time and capacitive domain. Selection is a procedure of choosing certain type of earthquakes or group of earthquakes according to the criteria set in advance, such as the selection according to the criteria whether earthquakes are far field ground motion (FFGM) or near field ground motion (NFGM), impulse or non-impulse ones, according to their magnitude, type of mechanism, distance from the location of initiation of propagation of seismic waves, velocity of shear waves in the ground in the top 30m of depth, hypo central distance or according to some other criteria. Formatting is the procedure of transformation of accelerogram record from the earthquake database and adaptation for the software for structural analysis, while conversion is the procedure of transformation of a measurement unit into the other one. Scaling is a set of procedures which directly or indirectly multiply values of acceleration of the accelerogram according to certain criteria. Scaling of accelerograms is performed by implementing several procedures, the following ones standing prominent: scaling of accelerograms in time domain, scaling of accelerograms in frequency domain, scaling through response spectrum implementing *Least Square Method* (LSM), scaling through the response spectrum by implementing genetic algorithm, spectral matching and similar procedures. Calculation is a set of procedures which determine basic parameters of accelerogram, such as intensity measures (IM), while processing is a set of procedures which can have different character such as *Base Line Correction* (BLC),

Line Correction), konstrukcija elastičnog i neelastičnog spektra odgovora i slične procedure. Kompatibilizacija je procedura kreiranja reprezentativnog (kompatibilnog) akceleroograma na osnovu jednog realnog ili grupe akceleroograma prema zadatom projektnom spektru odgovora. Normalizacija je procedura uravnoteženja dve komponente zemljotresa kada se koriste akceleroگرامи za bidirekciono seizmičko dejstvo, dok je filtriranje procedura primene određenih filtera u cilju eliminacije nebitnih frekvencijskih opsega i zadržavanja bitnih frekvencijskih opsega. Najčešće se koriste visokopropusni (HPF – *highpass*) i pojasnopropusni (BPF – *bandpass*), a takođe i niskopropusni (LPF – *lowpass*) i pojasna brana (BSF – *bandstop*) filter. Generisanje je procedura kreiranja novih akceleroograma, kao što su veštački (*artificial*) ili sintetički (*synthetic*) akceleroگرامи na osnovu definisanih procedura u frekventnom domenu. Ovi akceleroagramи se generišu kao nepotpuni nestacionarni ili potpuni nestacionarni akceleroagramи. Transformacija je procedura kojom se određuje frekvencijski sadržaj akceleroograma, odnosno vrednosti amplituda po frekvencijama u frekventnom domenu primenom *Fourier*-ovih transformacija.

Uvođenje prigušenja u modalnu NDA moguće je sprovesti primenom: prigušenja materijala, prigušenja kod nelinearnog ponašanja elemenata veze i prigušenja u analizi. Na slici 12 je prikazan dijagram toka uvođenja prigušenja kod modalne NDA. Prigušenje materijala se uvodi kao modalno prigušenje, dok se prigušenje elemenata veze uvodi uzimajući u obzir predefinisane parametre za nelinearno prigušenje i razvoj histerezisnog ponašanja. Prigušenje koje se direktno definiše u analizi uvodi se identično kao kod modalne LDA: konstantno prigušenje, interpolirano prigušenje i primenom faktora participacije mase i krutosti.

structure of elastic and inelastic response spectrum and similar procedures. Spectral matching is a procedure of creation of representative (compatible) accelerogram on the basis of one real or group of accelerograms according to the given design response spectrum. Normalization is the procedure of balancing two earthquake components when accelerograms for bidirectional seismic action are used, while filtering is the procedure of implementation of certain filters with the purpose of elimination of unimportant frequency range and retaining important frequency range. Highpass (HPF) and bandpass (BPF), as well as lowpass (LPF) and bandstop (BSF) filters are used most frequently. Generation is the procedure of creation of new accelerograms such as artificial or synthetic accelerograms, based on the defined procedures in frequency domain. These accelerograms are generated as incompletely non-stationary or completely non-stationary accelerograms. Transformation is the procedure used for determining the frequency content of an accelerogram, i.e. values of amplitudes by frequencies in a frequency domain via implementing *Fourier* transforms.

Damping in modal NDA analysis can be introduced by using: material damping, damping in the nonlinear behaviour of link elements and damping in the analysis. Figure 12 shows the flowchart of damping introduction into modal NDA. Material damping is introduced as modal damping, while damping of link elements is introduced taking into account the predefined parameters for nonlinear damping and the development hysteretic behaviour. Damping that is directly defined in the analysis is introduced in the same way as in modal LDA: constant damping, interpolated damping and using the factors of mass and stiffness participation.

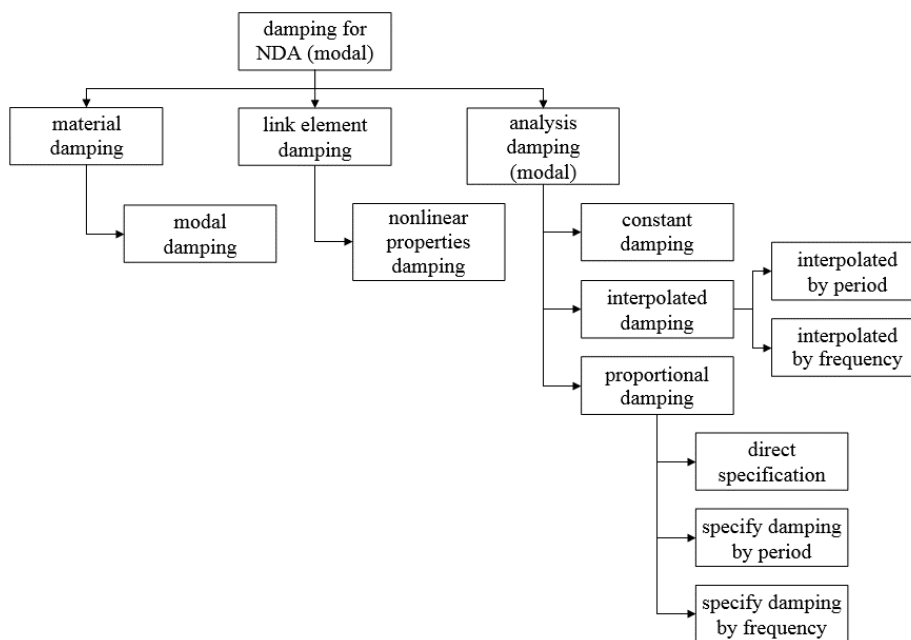

Slika 12. Dijagram toka uvođenja prigušenja kod modalne NDA [30]
Figure 12. Flowchart of introducing damping into modal NDA [30]

Diferencijalne jednačine kretanja sistema s više stepeni slobode, kod nelinearne dinamičke (modalne) analize, formulišu se u matricnom obliku [52]:

Differential equations of movement of system with several degrees of freedom, such as the modal NDA, are formulated in a matrix form [52]:

$$[M]\{\ddot{u}\} + [C]\{\dot{u}\} + [K]\{u\} + \{F\}_{NL} = \{F\}, \quad (22)$$

gde je $\{F\}_{NL}$ vektor sila koje potiču od elemenata veza s nelinearnim ponašanjem. Prilikom proračuna nelinearne dinamičke (modalne) analize formira se matrica prigušenja prema izrazu (22), a u zavisnosti od tipa prigušenja koje je definisano pre izvršenja analize. Efikasnost ove analize je u tome što se razdvaja vektor sila koje potiču od elemenata veza s nelinearnim ponašanjem od matrica elastične krutosti i prigušenja.

Uvođenje prigušenja u NDA (numerička integracija) moguće je sprovesti primenom: prigušenja materijala, prigušenja elemenata veze i prigušenja u analizi. Na slici 13 je prikazan dijagram toka uvođenja prigušenja kod NDA (numerička integracija). Prigušenje materijala se uvodi kao viskozno prigušenje, dok se prigušenje elemenata veze uvodi uzimajući u obzir predefinisane parametre za nelinearno prigušenje i razvoj histerezisnog ponašanja. Prigušenje koje se direktno definiše u analizi uvodi se identično kao kod LDA (numerička integracija). Diferencijalne jednačine kretanja sistema sa više stepeni slobode, kod NDA (numerička integracija), formulišu se analogno izrazu (22), s tim što se matrica krutosti formira uzimajući u obzir razvoj geometrijske i materijalne nelinearnosti, a proračunava primenom inkrementalno-iterativnog postupka. Prilikom proračuna NDA (numerička integracija) formira se matrica prigušenja prema izrazu (22), a u zavisnosti od tipa prigušenja koje je definisano pre izvršenja analize.

where $\{F\}_{NL}$ is the force vector coming from joint elements with nonlinear behaviour. During the calculation of modal NDA, a damping matrix is formed according to the expression (22), depending on the type of damping which is defined prior to the execution of the analysis. The efficiency of this analysis is reflected in separating the force vector originating from the link element with nonlinear behaviour from the matrix of elastic stiffness and damping.

In numerical integration NDA damping can be introduced by using: material damping, link element damping and damping in the analysis. Figure 13 shows the flowchart of damping introduction into numerical integration NDA. Material damping is introduced as viscous damping, while the link element damping is introduced taking into account the predefined parameters for nonlinear damping and the development hysteretic behaviour. Damping that is directly defined in the analysis is introduced in the same way as in numerical integration LDA. In numerical integration NDA, differential equations of movement of system with several degrees of freedom are formulated in analogy with expression (22), provided that the stiffness matrix is formed taking into account the development of geometric and material nonlinearity, and it is calculated using the incremental - iterative procedure. When calculating the numerical integration NDA the damping matrix is formed according to the expression (22), and depending on the type of damping which is defined prior to the execution of the analysis.

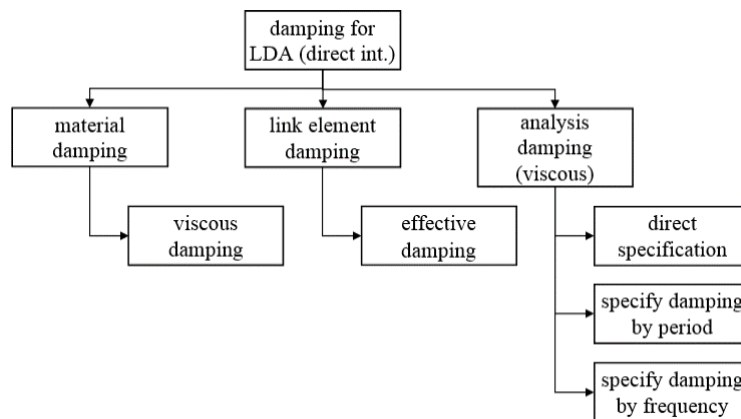

Slika 13. Dijagram toka uvođenja prigušenja kod NDA (numerička integracija) [30]
Figure 13. Flowchart of introducing damping into numerical integration NDA [30]

U slučaju izraženog nelinearnog ponašanja, usled stalnog pada krutosti sistema, nastupa konstantno smanjenje prigušenja, mada to i nema fizičkog opravdanja [14]. Tada je najpovoljnije da se matrica prigušenja formira na početku proračuna, kao proporcionalna početnoj linearnoj matrici krutosti uz zanemarenje člana koji je proporcionalan matrici masa. Objašnjenje za ovo leži u činjenici da su efekti histerezisne disipacije, kod nelinearnih sistema, dominantniji u odnosu na efekte viskoznog prigušenja, a koje je izraženo kod linearnih sistema. Eliminacija člana koji je proporcionalan matrici masa omogućava veće prigušenje viših svojstvenih oblika u odnosu na prigušenje nižih svojstvenih oblika.

Constant reduction of damping occurs in the case of pronounced nonlinear behaviour due to constant reduction of the system stiffness, although it lacks any physical justification [14]. Beginning of calculation is the best time to form the damping matrix as proportional to initial linear stiffness matrix while neglecting the member which is proportional to the mass matrix. This can be explained by the fact that effects of hysteretic dissipation in nonlinear systems are more dominant than the effects of viscous damping, which is more expressed in linear systems. Eliminating the member which is proportional to the mass matrix allows higher eigenforms to be damped more than the lower eigenforms.

7 SEIZMIČKE ANALIZE PREMA PERFORMANCE-BASED EARTHQUAKE ENGINEERING (PBEE)

Performance-Based Earthquake Engineering (PBEE) metodologija je inicirana u poslednjih dvadesetak godina prvo na determinističkom, a zatim i na probabilističkom nivou. PBEE metodologija se zasniva na multidisciplinarnom pristupu putem: računarske mehanike, numeričke metode, dinamike konstrukcija, nelinearne analize, teorije armiranobetonskih konstrukcija, teorije plastičnosti, mehanike loma, interakcije konstrukcija–tlo, zemljotresnog inženjerstva, inženjerske seizmologije, primene savremenih propisa za projektovanje konstrukcija, inženjerske statistike i verovatnoće. Razvoj savremene PBEE metodologije omogućava kompletnije i kompleksnije sagledavanje i tretiranje problema analizom hazarda (*hazard analysis*), analizom konstrukcije (*structural analysis*), analizom oštećenja (*damage analysis*) i analizom štete (*loss analysis*) [36], [41]. Analiza hazarda se predstavlja promenljivom mere intenziteta (IM), kojim se kvantifikuje pomeranje tla, dok se analiza konstrukcije predstavlja primenom inženjerskog parametra zahteva (EDP). Analiza oštećenja se predstavlja promenljivom mere oštećenja (DM), a analiza štete promenljivom odluke (DV). Uspostavljanje veze između IM i EDP sprovodi se preko modela seizmičkog zahteva (*seismic demand model*), a koji se određuje primenom probabilističke analize seizmičkog zahteva (PSDA – *Probabilistic Seismic Demand Analysis*) i INDA analize. Međutim, pre uspostavljanja veze EDP–IM potrebno je razmotriti IM promenljivu primenom probabilističke analize seizmičkog hazarda (PSHA – *Probabilistic Seismic Hazard Analysis*). Na osnovu određenog IM iz PSHA i EDP iz PSDA, NDA ili čak preko NSPA, uspostavlja se korelacija EDP–IM, najčešće preko spektralnog ubrzanja za IM i globalnog ili međuspratnog drifta za EDP. Model seizmičkog zahteva u PSDA analizi se može predstaviti i preko krivih povredljivosti (*fragility curves*). Uspostavljanje veze između EDP i DM sprovodi se preko modela oštećenja (*damage model*), a koji se određuje primenom probabilističke analize seizmičkog oštećenja (PSDamA – *Probabilistic Seismic Damage Analysis*), INDA ili NSPA, dok se uspostavljanje veze između DM i DV sprovodi preko modela štete (*loss model*), a koji se određuje primenom probabilističke analize seizmičke štete (PSLA – *Probabilistic Seismic Loss Analysis*), INDA ili NSPA.

8 ZAVRŠNE NAPOMENE

Primenom sprovedene sistematizacije seizmičkih analiza može se vrlo efikasno razmotriti koji tip analize se može primeniti u fazama preliminarnih i finalnih analiza za naučna istraživanja i stručne projekte. Autori su napravili sopstvenu sistematizaciju seizmičkih analiza, s tim što pojedine seizmičke analize mogu pripadati i prelaznim kategorijama analiza. Posebno je to slučaj kod onih analiza koje koriste multidisciplinarnu formulaciju problema, pa naučnoj i stručnoj javnosti ostaje da detaljnije razmotre matematičke formulacije svih pojedinačnih seizmičkih analiza.

Na konceptualnom nivou, uvođenje prigušenja u analizu konstrukcija trebalo bi razmatrati u funkciji tipa analize, da li je u pitanju linearna ili nelinearna analiza, odnosno u funkciji tipa domena u kojem se razmatra odgovor sistema, gde postoji mogućnost razmatranja u

7 SEISMIC ANALYSES ACCORDING TO PERFORMANCE-BASED EARTHQUAKE ENGINEERING (PBEE)

PBEE methodology has been initiated in the recent twenty years, firstly on deterministic and then probabilistic level. PBEE methodology is based on multidisciplinary approach through: computer mechanics, numerical methods, structural dynamics, nonlinear analyses, theory of reinforced concrete structures, theory of plasticity, failure mechanics, soil-structure interaction, earthquake engineering, engineering seismology, implementation of contemporary regulations for structural design, engineering statistics and probability. Development of contemporary PBEE methodology facilitates a more complete and complex analysis and treatment of the problem through hazard analysis, structural analysis, damage analysis and loss analysis [36], [41]. Hazard analysis is represented by variable intensity measure (IM), which quantifies ground displacement, while structural analysis is represented by implementation of engineering demand parameter (EDP). Damage analysis is represented by variable damage measure (DM), and loss analysis by variable decision variables (DV). Relation is established between IM and EDP through seismic demand model, which is determined by implementation of *Probabilistic Seismic Demand Analysis* (PSDA) and INDA. However, prior to establishing relation EDP-IM it is necessary to consider IM variable by implementing *Probabilistic Seismic Hazard Analysis* (PSHA). Based on the IM determined from PSHA and on EDP from PSDA, NDA or even via NSPA, a correlation EDP-IM is established, most often via the spectral acceleration for IM and global or inter storey drift for EDP. Model of seismic demand in PSDA analysis can be represented via fragility curves. Establishment of correlation between EDP and DM is conducted via damage model, which is determined by implementation of *Probabilistic Seismic Damage Analysis* (PSDamA), INDA or NSPA, while establishment of correlation between DM and DV is conducted using loss model, and determined by implementation of *Probabilistic Seismic Loss Analysis* (PSLA), INDA or NSPA.

8 CONCLUSION REMARKS

By implementing the conducted systematization of nonlinear seismic analyses, one can efficiently analyze which type of analysis can be implemented in the phases of preliminary and final analyses for scientific research and professional projects. The authors created their own systematization of analyses, considering that certain nonlinear seismic analysis can belong to transitional categories of analyses. It is particularly the case in those analyses which employ multidisciplinary problem formulation, thus a more in-detail consideration of mathematical formulations of all individual nonlinear seismic analyses remains to be performed.

At the conceptual level, damping introduction into structural analysis should be considered as a function of the type of analysis (linear or nonlinear analysis), that is, a function of the domain type in which the system

kapacitativnom, vremenskom ili frekventnom domenu. Budući da modeliranje prigušenja u analizi konstrukcija predstavlja jednu od najvećih nepoznanica, to je ovim naučnim istraživanjem ponuđeno inženjerskoj javnosti da se putem dijagrama tokova mogu otkloniti već postojeće nedoumice u vezi s modeliranjem prigušenja. Klasičan pristup kojim se uvodi prigušenje u analizu konstrukcija bazira se na koeficijentu relativnog prigušenja ξ . Međutim, treba znati da nije ekvivalentno kada se uzima u obzir koeficijent relativnog prigušenja i kada se (histerezisno) prigušenje uvodi u analizu primenom faktora participacije mase i krutosti α i β , a koji su određeni za vrednost koeficijenta relativnog prigušenja. Takođe, prilikom uvođenja prigušenja u analizu treba voditi računa o tome da se dodatno ne ignoriše postojanje prigušenja u sistemu, da se ne dupliraju vrednosti prigušenja ili da se uvodi prigušenje istog tipa, a na dva različita načina.

Zahvalnost: Ovaj rad je proistekao iz dela istraživačkog projekta TR 36043, koji je podržan od strane Ministarstva prosvete i nauke Republike Srbije. Zahvaljuje se na ovoj podršci (R. Folić).

9 LITERATURA REFERENCES

- [1] Abdelraheem Farghaly A.: Parametric Study on Equivalent Damping Ratio of Different Composite Structural Building Systems, Steel and Composite Structures, Vol. 14, No. 4, pp. 349–365, 2013.
- [2] Adhikari S.: *Damping Models for Structural Vibration*, PhD Dissertation, Cambridge University, Cambridge, UK, 2000.
- [3] Antoniou S., Pinho R.: *Development and Verification of a Displacement-Based Adaptive Pushover Procedure*, Journal of Earthquake Engineering, Vol. 8, No. 5, pp. 643–661, 2003.
- [4] Antoniou S., Pinho R.: *Advantages and Limitations of Adaptive and Non-Adaptive Force Based Pushover Procedures*, Journal of Earthquake Engineering, Vol. 8, No. 4, pp. 497–522, 2004.
- [5] Aschheim M., Black E.: *Yield Point Spectra for Seismic Design and Rehabilitation*, Earthquake Spectra, Vol. 16, No. 2, pp. 317–335, 2000.
- [6] ATC 40, *Seismic Evaluation and Retrofit of Concrete Buildings, Vol. 1*, Applied Technology Council, Redwood City, USA, 1996.
- [7] Avnani M., Estekanchi H.: *Collapse Analysis by Endurance Time Method*, International Journal of Optimization in Civil Engineering, Vol. 2, No. 2, pp. 287–299, 2012.
- [8] Aydinogly M.: An Incremental Response Spectrum Analysis Procedure Based on Inelastic Spectral Displacements for Multi-Mode Seismic Performance Evaluation, Bulletin of Earthquake Engineering, Vol. 1, No. 1, pp. 3–36, 2003.
- [9] Azarbakht A., Dolšek M.: *Progressive Incremental Dynamic Analysis for First-Mode Dominated Structures*, ASCE Journal of Structural Engineering, Vol. 137, 2011.
- [10] Bhatt C., Bento R.: The Extended Adaptive Capacity Spectrum Method for the Seismic Assessment of Plan-Asymmetric Buildings, Earthquake Spectra, Vol. 30, No. 2, pp. 683–703, 2014.
- [11] Casarotti C., Pinho R.: *An Adaptive Capacity Spectrum Method for Assessment of Bridges Subjected to Earthquake Action*, Bulletin of Earthquake Engineering, Vol. 5, No., pp. 377–390, 2007.
- [12] Chopra A.: *Dynamics of Structures: Theory and Applications to Earthquake Engineering*, Prentice-Hall, Englewood Cliffs, USA, 1995.
- [13] Chopra A., Goel R.: *A Modal Pushover Analysis Procedure to Estimating Seismic Demands for Buildings*, Pacific Earthquake Engineering Research Center, University of California Berkeley, PEER Report 2001/03, 2001.
- [14] *CSI Analysis Reference Manual*, Computers and Structures, Berkeley, USA, 2009.
- [15] Čosić M., Brčić S.: „Metodologija pripreme i obrade akcelorograma za linearne i nelinearne seizmičke analize konstrukcija”, Izgradnja Vol. 66, No. 11–12, pp. 511–526, 2012.
- [16] Čosić M., Brčić S.: *Iterative Displacement Coefficient Method: Mathematical Formulation and Numerical Analyses*, Journal of the Croatian Association of Civil Engineers, Vol. 65, No. 3, pp. 199–211, 2013.
- [17] Čosić M., Brčić S.: *The Development of Controlled Damage Mechanisms-Based Design Method for Nonlinear Static Pushover Analysis*, Facta Universitatis - Series: Architecture and Civil Engineering, Vol. 12, No. 1, pp. 25–40, 2014.
- [18] Čosić M.: „Nelinearna statička i dinamička seizmička analiza okvirnih zgrada prema performansama”, doktorska disertacija, Građevinski fakultet, Univerzitet u Beogradu, Beograd, 2015.
- [19] Čosić M., Folić R.: *Performance Analysis of Damaged Buildings Applying Scenario of Related Non-Linear Analyses and Damage Coefficient*, Building materials and structures, Vol. 58, No. 3, pp. 3–27, 2015.
- [20] Di Sarno L, Elnashai A.: *Fundamentals of Earthquake Engineering*, John Wiley & Sons, Chichester, UK, 2008.
- [21] Dolšek M., Fajfar P.: *IN2 - A Simple Alternative for IDA*, The 13th World Conference on Earthquake Engineering, Paper No. 3353, Vancouver, Canada, 2004.
- [22] Dolšek M.: *Estimation of Seismic Response Parameters Through Extended Incremental Dynamic Analysis*, Computational Methods in Earthquake Engineering, Vol. 21, pp. 285–304, 2010.

- [23] EN 1998-1:2004, *Eurocode 8: Design of Structures for Earthquake Resistance – Part 1: General Rules, Seismic Actions and Rules for Buildings*, Brussels, Belgium, 2004.
- [24] Fajfar P.: *A Nonlinear Analysis Method for Performance-Based Seismic Design*, *Earthquake Spectra*, Vol. 16, No. 3, pp. 573–592, 2000.
- [25] FEMA 356, *Pre-Standard and Commentary for the Seismic Rehabilitation of Buildings*, American Society of Civil Engineers, Federal Emergency Management Agency, Washington D. C., USA, 2000.
- [26] FEMA 440, *Improvement of Nonlinear Static Seismic Analysis Procedures*, Applied Technology Council (ATC-55 Project), Federal Emergency Management Agency, Washington D. C., USA, 2005.
- [27] FEMA 750P, *NEHRP Recommended Seismic Provisions for New Buildings and Other Structures*, Building Seismic Safety Council, Federal Emergency Management Agency, Washington D. C., USA, 2009.
- [28] FEMA P-58-1, *Seismic Performance Assessment of Buildings, Methodology*, Applied Technology Council, Federal Emergency Management Agency, Washington, USA, 2012.
- [29] FEMA P-58-2, *Seismic Performance Assessment of Buildings, Implementation Guide*, Applied Technology Council, Federal Emergency Management Agency, Washington D. C., USA, 2012.
- [30] Folić R., Čosić M., Folić B.: *Damping Models for Flow Chart Based Structural Analysis*, The 15th International Science Conference VSU, Sofia, Bulgaria, pp. 155–164, 2015.
- [31] Folić R., Čosić M.: *Performance-Based Non-linear Seismic Methods of Structures: A Review of Scientific Knowledge in the Last 20 Years*, The 16th International Scientific Conference VSU, Sofia, Bulgaria, pp. 146–156, 2016.
- [32] Freeman S.: *Review of the Development of the Capacity Spectrum Method*, *ISET Journal of Earthquake Technology*, Paper No. 438, Vol. 41, No. 1, pp. 1–13, 2004.
- [33] Guyader A., Iwan W.: *An Improved Capacity Spectrum Method Employing Statistically Optimized Linearization Parameters*, The 13th World Conference on Earthquake Engineering, Paper No. 3020, Vancouver, Canada, 2004.
- [34] Kalkan E., Kunnath S.: *Method of Modal Combinations for Pushover Analysis of Buildings*, The 13th World Conference on Earthquake Engineering, Paper No. 2713, Vancouver, Canada, 2004.
- [35] Kovačević D.: „MKE modeliranje u analizi konstrukcija”, *Građevinska knjiga*, Beograd, 2006.
- [36] Krawinkler H.: *Challenges and Progress in Performance-Based Earthquake Engineering*, International Seminar on Seismic Engineering for Tomorrow - In Honor of Professor Hiroshi Akiyama, Tokyo, Japan, pp. 1–10, 1999.
- [37] Lagaros N.: *Multicomponent Incremental Dynamic Analysis Considering Variable Incident Angle, Structure and Infrastructure Engineering: Maintenance, Management, Life-Cycle Design and Performance*, Vol. 6, No. 1–2, pp. 77–94, 2010.
- [38] Liao W.-C.: *Performance-Based Plastic Design of Earthquake Resistant Reinforced Concrete Moment Frames*, Doctoral dissertation, The University of Michigan, Ann Arbor, USA, 2010.
- [39] Lin T., Baker J.: *Introducing Adaptive Incremental Dynamic Analysis: A New Tool for Linking Ground Motion Selection and Structural Response Assessment*, Safety, Reliability, Risk and Life-Cycle Performance of Structures & Infrastructures, Taylor & Francis Group, London, UK, pp. 805–811, 2013.
- [40] Manoukas G., Avramidis.: *Improved Multimode Pushover Procedure for Asymmetric in Plan Buildings Under Biaxial Seismic Excitation – Application to Tall Buildings*, *The Structural Design of Tall and Special Buildings*, Vol. 24, No. 6. pp. 397–420, 2014.
- [41] Moehle J., Krawinkler H.: *A Framework Methodology for Performance-Based Earthquake Engineering*, The 13th World Conference on Earthquake Engineering, Paper No. 679, Vancouver, Canada, 2004.
- [42] Moon K., Han S., Lee T., Seok S.: *Approximate MPA-Based Method for Performing Incremental Dynamic Analysis*, *Nonlinear Dynamics*, Vol. 67, No. 4, pp. 2865–2888, 2011.
- [43] Newmark N., Hall W.: *Earthquake Spectra and Design*, Earthquake Engineering Research Institute (EERI), Berkeley, USA, 1982.
- [44] Peloso S., Pavese A.: *Secant Modes Superposition: A Simplified Method for Seismic Assessment of RC Frames*, The 14th World Conference on Earthquake Engineering, Beijing, China, Paper No. 14_05-01-0254, 2008.
- [45] Priestley M., Calvi G., Kowalsky M.: *Displacement-Based Seismic Design of Structures*, IUSS Press, Pavia, Italy, 2007.
- [46] Puthanpurayil A., Dhakal R., Carr A.: *Modelling of In-Structure Damping: A Review of the State-of-the-Art*, IX Pacific Conference on Earthquake Engineering Building an Earthquake-Resilient Society, Paper no. 091, Auckland, New Zealand, 2011.
- [47] Ramirez O., Constantinou M., Whittaker A., Kircher C., Chrysostomou C.: *Elastic and Inelastic Seismic Response of Buildings with Damping Systems*, *Earthquake Spectra*, Vol. 18, No. 3, pp. 531–547, 2002.
- [48] Smyrou E., Priestley N., Carr A.: *Modelling of Elastic Damping in Nonlinear Time-History Analyses of Cantilever RC Walls*, *Bulletin of Earthquake Engineering*, Vol. 9, No. 5, pp. 1559–1578, 2011.
- [49] Stojnić N., Kuzović D.: *Proposal of Reducing Seismic Damages on Immovable Cultural Properties (Building Structures)*, *Building materials and structures*, Vol. 59, No. 4, pp. 31–46, 2016.
- [50] Vamvatsikos D.: *Seismic Performance, Capacity and Reliability of Structures as Seen Through Incremental Dynamic Analysis*, PhD Dissertation, Stanford University, Stanford, USA, 2002.
- [51] Vamvatsikos D., Cornell A.: *Incremental Dynamic Analysis*, *Earthquake Engineering and Structural Dynamics*, Vol. 31, No. 3, pp. 491–514, 2002.
- [52] Wilson E.: *Three-Dimensional Static and Dynamic Analysis of Structures*, Computers and Structures, Inc., 2002.

- [53] Yu H., Lu D-G., Song P-Y., Wang G-Y.: *Stochastic Incremental Dynamic Analysis Considering Random System Properties*, The 14th World Conference on Earthquake Engineering, Beijing, China, Paper No. 14_S15-047, 2008.
- [54] Yu-Yuan L., Kuo-Chun C.: *An Improved Capacity Spectrum Method for ATC-40*, Earthquake Engineering & Structural Dynamics, Vol. 32, No. 13, pp. 2013-2025, 2003.

- [55] Yu-Yuan L., Miranda E.: *Non-Iterative Capacity Spectrum Method Based on Equivalent Linearization for Estimating Inelastic Deformation Demands of Buildings*, Structural Engineering / Earthquake Engineering, Vol. 21, No 2, pp. 113-119, 2004.

REZIME

PREGLED SAVREMENIH SEIZMIČKIH ANALIZA I NAČINA UVOĐENJA PRIGUŠENJA U NJIMA

Mladen ĆOSIĆ
Radomir FOLIĆ
Stanko BRČIĆ

Autori rada su, na osnovu analize velikog broja naučnih radova, dali prikaz sopstvene originalne sistematizacije seizmičkih analiza konstrukcija, a veliki deo njih je razvijen u poslednje dve decenije. Seizmičke analize su klasifikovane generalno u dve (četiri) grupe: linearne i nelinearne statičke analize; i linearne i nelinearne dinamičke analize. Posebno su klasifikovane analize nelinearnog seizmičkog odgovora konstrukcija, a posebno analize ciljnog pomeranja kojim se definiše odnos seizmičkog zahteva i seizmičkog odgovora. S druge strane, klasifikacija je sprovedena i u funkciji da li se nelinearan odgovor sistema dobija primenom inkrementalno-iterativnih procedura ili primenom poluiterativnih i/ili poluinkrementalnih procedura. Nelinearne dinamičke analize su klasifikovane prema konceptu matematičke formulacije, odnosno da li se zasnivaju na samo jednoj dinamičkoj analizi, većem broju dinamičkih analiza ili dobijaju rešenja u kombinaciji s drugim metodama. Primenom sprovedene sistematizacije seizmičkih analiza može se vrlo efikasno razmotriti koji tip analize je optimalan za analizu konstrukcija i koji tip analize je potrebno uzeti u obzir u fazi preliminarnih i finalnih analiza za naučna istraživanja i stručne projekte.

U radu su, takođe, prikazani aspekti modeliranja prigušenja u analizi konstrukcija sistematizacijom tipova prigušenja i formiranim dijagramima tokova, a u zavisnosti od tipa primenjene analize: linearne i nelinearne, statičke i dinamičke. Sistematizacija prigušenja je sprovedena prema načinu uvođenja u proračun i to preko prigušenja materijala, prigušenja elemenata veze i prigušenja koja se direktno uvode u analize, a koje se sprovode u kapacitativnom, vremenskom i frekventnom domenu. Primenom razvijenih dijagrama tokova, u procesu kreiranja numeričkih modela konstrukcija, može se vrlo efikasno razmotriti koji tip prigušenja treba odabrati i na koji način uvesti prigušenje u analizu konstrukcija. Takođe, primenom razvijenih dijagrama tokova mogu se definisati i alternativni pristupi uvođenja prigušenja u analizu konstrukcija.

Ključne reči: seizmičke analize, prigušenje, sistematizacija, performanse, konstrukcije

SUMMARY

AN OVERVIEW OF MODERN SEISMIC ANALYSES WITH DIFFERENT WAYS OF DAMPING INTRODUCTION

Mladen COSIC
Radomir FOLIC
Stanko BRCIC

The authors of the paper, on the basis of the analysis of a large number of scientific papers, presented their original systematization of seismic analyses of structures, where a large number of them were developed during the last twenty years. Seismic analyses are generally classified into two (four) groups: *Linear Static Analyses* (LSA) and *Nonlinear Static Analyses* (NSA), and *Linear Dynamic Analyses* (LDA) and *Nonlinear Dynamic Analyses* (NDA). The analyses of nonlinear seismic structural response were classified separately from the *Target Displacement Analyses* (TDA) which defines the relationship of the seismic demand and seismic response. On the other hand, classification was also conducted depending on whether a nonlinear response of the system is obtained by the implementation of incremental-iterative procedures or by implementation of semi-iterative and/or semi-incremental procedures. NDA were classified according to the concept of mathematical formulation, i.e. whether they are based on only one dynamic analysis, several dynamic analyses or they are solved in combination with other methods. By implementing the conducted systematization of seismic analyses, one can efficiently consider which type of analysis is optimal for structural analysis and which type of analysis should be taken into account in the phase of preliminary and final analyses in the course of scientific research and professional projects.

This paper also presents the aspects of damping modelling in structural analysis through the systematization of damping types and flowcharts, depending on the type of analysis applied: linear and nonlinear, static and dynamic. Damping has been systematized based on the way it was introduced into calculations, i.e. over material damping, link element damping and damping directly introduced into the analyses which are conducted in capacitive, time and frequency domains. In the process of creating numerical structural models, the type of damping and the way of its introduction into structural analysis can be very efficiently selected by applying the flow charts developed. By applying the developed flowcharts, alternative approaches to the introduction of damping into structural analysis can also be defined.

Keywords: seismic analyses, damping, systematization, performances, structures

FIBER KONAČNI ELEMENT U NELINEARNOJ ANALIZI KVADRATNIH SPREGNUTIH CFT STUBOVA

FIBER FINITE ELEMENT IN NONLINEAR ANALYSIS OF SQUARE CFT COLUMNS

Nikola BLAGOJEVIĆ
Svetlana M. KOSTIĆ
Saša STOŠIĆ

PREGLEDNI RAD
REVIEW PAPER
UDK:624.012.45
doi:10.5937/grmk1701031B

1 UVOD

Čelične cevi ispunjene betonom, to jest CFT (*Concrete Filled Tubes - CFT*) stubovi predstavljaju jedan od tipova spregnutih stubova. Pri opisivanju njihovog ponašanja, neophodno je imati u vidu različite nelinearne uticaje koji ih karakterišu. U ovom radu predložen je numerički model za nelinearnu analizu kvadratnih CFT stubova, baziran na primeni fiber konačnog elementa raspodeljene plastičnosti. Prema dosadašnjim istraživanjima, ovaj konačni element pokazao se kao dosta pouzdan – kako prilikom modeliranja čeličnih i betonskih, tako i u slučaju spregnutih konstrukcija [1], [2]. Ovde su analizirani njegova primena i izbor parametara modela prilikom opisivanja nelinearnog ponašanja uzoraka izloženih delovanju statičkog opterećenja, pri različitoj vitkosti uzoraka, različitom odnosu D/t (odnos ukupne dimenzije čeličnog profila $[D]$ i debljini čeličnog profila $[t]$), kao i uzoraka izloženih različitim tipovima statičkog naprezanja. Tačnost modela proverena je upoređivanjem sa eksperimentalnim podacima dostupnim u literaturi.

1 INTRODUCTION

Steel tubes filled with concrete, also known as CFT (*Concrete Filled Tubes - CFT*) columns represent one type of composite columns. To model their behaviour appropriately, it is necessary to take into account different nonlinear effects. In this work, a numerical model based on distributed plasticity fiber element is presented. According to previous studies, fiber element has shown great reliability in modelling steel, concrete and composite structures [1], [2]. The application of the previously defined numerical model and determination the model parameters is presented. The ability to model nonlinear behaviour of samples exposed to static load with different slenderness, D/t ratio (where D is the total dimension of a cross section and t is the thickness of steel tube) and different loading conditions has been analyzed. Accuracy of the model has been verified by comparing numerical results with experiments found in literature.

Nikola Blagojević, mast. inž. građ.
Građevinski fakultet Univerziteta u Beogradu, Bulevar kralja Aleksandra 73, 11000 Beograd,
e-mail: nblagojevic@grf.bg.ac.rs
Doc. dr Svetlana Kostić, dipl. inž. građ.
Građevinski fakultet Univerziteta u Beogradu, Bulevar kralja Aleksandra 73, 11000 Beograd,
e-mail: svetlana@grf.bg.ac.rs
Doc. dr Saša Stošić, dipl. inž. građ.
Građevinski fakultet Univerziteta u Beogradu, Bulevar kralja Aleksandra 73, 11000 Beograd, e-mail: sasa@grf.bg.ac.rs

Nikola Blagojevic, teaching assistant, MSc.
Faculty of Civil Engineering, University of Belgrade, Bulevar kralja Aleksandra 73, Belgrade,
e-mail: nblagojevic@grf.bg.ac.rs
Svetlana Kostic, assistant professor, PhD.
Faculty of Civil Engineering, University of Belgrade, Bulevar kralja Aleksandra 73, Belgrade,
e-mail: svetlana@grf.bg.ac.rs
Sasa Stosic, assistant professor, PhD.
Faculty of Civil Engineering, University of Belgrade, Bulevar kralja Aleksandra 73, Belgrade, e-mail: sasa@grf.bg.ac.rs

2 OPIS CFT STUBOVA

U novijoj inženjerskoj praksi, CFT stubovi se sve više koriste budući da poseduju brojne prednosti u poređenju s čisto čeličnim i čisto betonskim stubovima [3], [4]. Usled toga što se čelični profil nalazi na spoljašnjoj ivici preseka (Slika 1), CFT stubovi imaju povoljne geometrijske karakteristike, veliku krutost, kao i nosivost na savijanje. Beton – koji može biti armiran ili nearmiran - ispunjava centralni deo preseka, i time povećava nosivost preseka na pritisak i sprečava izbočavanje čelične cevi „ka unutra”. Visoka duktilnost CFT stubova čini ih posebno interesantnim za primenu u seizmički aktivnim područjima [5].

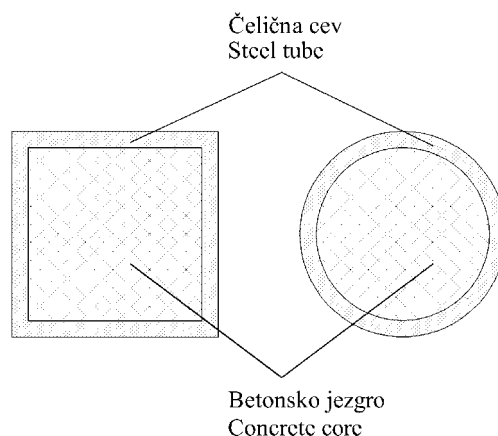

Slika 1. Tipični poprečni preseki CFT stubova
Figure 1. Typical cross sections of CFT columns

3 PONAŠANJE CFT STUBOVA

Dosadašnja eksperimentalna istraživanja [5]–[7] potvrdila su da je ponašanje CFT stubova nelinearno usled brojnih efekata kao što su: pojava pukotina u betonu, utezanje betona, viskozne deformacije betona (tečenje i skupljanje), tečenje čeličnog dela preseka, prisustvo rezidualnih napona u čeliku, izbočavanje čeličnog dela preseka, i tako dalje.

CFT stubovi najčešće su dominantno izloženi naponima pritiska. Pri dilatacijama u čeliku i betonu većim od 1‰, dolazi do pojave pukotina u betonu, povećanja njegove zapremine i sadejstva ova dva materijala [8]. Tada čelični presek deluje poput uzengija, uteže beton i time - zbog triaksijalnog stanja napona koje se javlja u betonu - povećava se čvrstoća betona na pritisak. S obzirom na oblik poprečnog preseka, efekat utezanja betona izraženiji je kod kružnih poprečnih preseka nego kod pravougaonih i kvadratnih [8]. Međutim, eksperimentalna istraživanja pokazala su da u određenim slučajevima ovaj efekat ne dolazi do izražaja. Naime, u slučaju vitkih CFT stubova sa odnosom L/D većim od 15, dolazi do izvijanja stuba, tj. gubitka stabilnosti, pre nego što dilatacije u betonu dostignu vrednost pri kojoj se pojavljuju pukotine i porast zapremine betona [9]. Stoga, budući da nema sadejstva betona i čelika, nema ni efekta utezanja betona. Takođe, pokazano je da je povećanje čvrstoće betona usled efekta utezanja zanemarljivo i kod ekscentrično opterećenih kružnih i pravougaonih stubova ukoliko je

2 DESCRIPTIONS OF CFT COLUMNS

In recent engineering practice, the use of CFT columns is increasing due to numerous advantages relative to steel or reinforced concrete columns [3], [4]. Since steel tube forms the exterior of the cross section (Figure 1), it provides CFT columns with large moment of inertia, leading to high stiffness and flexural capacity. The concrete, that can also be reinforced, fills the core of the cross section increasing compressive strength of the CFT column and also delaying local buckling of the steel tube by forcing all buckling modes outward. The use of CFT columns is of great interests in seismically active areas due to their high ductility[5].

3 BEHAVIOUR OF CFT COLUMNS

Previous studies[5]–[7] have confirmed that the behaviour of CFT columns is nonlinear due to numerous effects such as: cracking of the concrete, confining effect in concrete, viscous deformations (creep and shrinkage), yielding of the steel tube, residual stresses, buckling of the steel tube, etc.

CFT columns are predominantly exposed to compressive loading. The confining effects take place at an axial strain of approximately 1‰ when micro cracking in concrete start to occur and lateral expansion rate of concrete increases approaching lateral expansion rate of steel [8]. At that point, the steel tube acts as stirrups and confines concrete resulting in an increase in compressive strength due to triaxial stresses in concrete. Circular steel tubes provide higher degree of confinement than flat sides of rectangular tubes, hence, the increase of compressive strength due to confining effect is more evident in circular than in rectangular cross sections [8]. However, experiments have shown that confining effect is negligible under certain conditions. In slender CFT columns, when L/D ratio is higher than 15, loss of stability can appear even before axial strain in concrete achieves value when confining effects occur. In these cases increase in ductility and compressive strength of concrete due to confinement effect should be neglected [9]. In addition, when square or circular CFT columns are loaded eccentrically, it is shown that for e/D (e being force eccentricity) ratio

odnos e/D (e – ekscentricitet sile) veći od 0.125 [7].

U ovom radu, nelinearno ponašanje čelika i betona (sastavnih materijala CFT stuba) uzeto je u obzir primenom odgovarajućih nelinearnih konstitutivnih modela za ove materijale. Efekat utezanja betona buhvaćen je modifikovanjem konstitutivnih relacija za beton. Uticaji koji su zanemareni u prikazanoj numeričkoj analizi jesu: viskozne deformacije betona (tečenje i skupljanje betona), lokalno izbočavanje čeličnog dela preseka i rezidualni naponi u čeličnom delu preseka. Naime, budući da čelična cev obavlja betonski deo preseka, ceo sistem je zatvoren i nema značajnijih promena vlažnosti uzrokovanih uticajima spoljašnje sredine. Stoga, kao što su potvrdila i eksperimentalna istraživanja [10], uticaj skupljanja i tečenja uglavnom je zanemarljiv. Takođe, zbog betona koji ispunjava CFT stub, lokalno izbočavanje čeličnog dela preseka izraženo je samo kod preseka s malom debljinom čeličnog profila. Kao granica za D/t , kod pravougaonih preseka obično se usvaja vrednost $\sqrt{3E/f_y}$ [10] i – ukoliko je odnos D/t

manji od pomenute granice - do lokalnog izbočavanja dolazi tek nakon što se čelični deo preseka plastifikuje. Stubovi razmatrani u ovom radu zadovoljavaju datu granicu, pa lokalno izbočavanje nije razmatrano. Uticaj rezidualnih napona je zanemaren i predmet je naknadne studije.

4 NUMERIČKI MODEL

Nasuprot brojnim eksperimentalnim istraživanjima CFT stubova, do sada je razvijeno relativno malo numeričkih modela kojima bi se moglo opisati njihovo ponašanje. Za detaljno modeliranje veza CFT stubova s gredama obično se koriste 3D solid konačni elementi, što je - s obzirom na malu kompjutersku efikasnost ovakvih modela - neprihvatljivo prilikom modeliranja čitavih konstrukcija. Stoga, u modeliranju celih konstrukcija i dalje se prvenstveno koriste linijski konačni elementi.

U ovom radu je za modeliranje kvadratnih CFT stubova korišćen fiber konačni element raspodeljene plastičnosti, formulisan prema metodi sila [2], koji se pokazao kao vrlo efikasan i pouzdan u modeliranju čeličnih i betonskih, kao i spregnutih konstrukcija [1], [2]. Kod ovog elementa, posmatra se određeni broj poprečnih preseka duž ose elementa. Vršni se diskretizacija svakog od ovih poprečnih preseka na određeni broj vlakana (fiber-a). Svakom vlaknu poprečnog preseka dodeljuje se odgovarajuća konstitutivna relacija kojom se opisuje ponašanje materijala koje dato vlakno predstavlja (Slika 2). Integracijom po čitavom poprečnom preseku, dobijaju se sile u preseku (aksijalna sila i momenti savijanja) i matrica krutosti preseka (1), (2).

$$K_S = \sum_{i=1}^N E_{ii} \begin{bmatrix} 1 & -y_i & z_i \\ -y_i & y_i^2 & -y_i \cdot z_i \\ z_i & -y_i \cdot z_i & z_i^2 \end{bmatrix} \cdot A_i \quad (1)$$

higher than 0.125 increase in concrete strength since the confinement effect can be neglected[7].

In this work, nonlinear material models are used to take into account nonlinear behaviour of steel and concrete, parts of a CFT column cross-section. Confinement effect is taken into account using modified constitutive models for concrete. Viscous deformations of concrete, buckling of steel tube and residual stresses in steel are neglected. In CFT columns, the effect of viscous deformations has much smaller influence than in reinforced concrete columns. The steel tube serves as an enclosed environment, so conditions remain ideally humid minimizing the effects of creep and shrinkage [10]. Also, due to concrete core, local buckling of steel tube is postponed. Local buckling should be taken into account in CFT columns with small thickness of the steel tube. In rectangular cross sections, if D/t ratio is smaller than $\sqrt{3E/f_y}$ local buckling will not occur before steel yields [10]. All CFT columns considered in this paper have D/t ratios smaller than $\sqrt{3E/f_y}$, and the effect of

local buckling was not included in the numerical model. Residual stresses in steel tube are neglected, and are a subject of the future study.

4 NUMERICAL MODEL

Contrary to numerous experimental research of CFT column, relatively few numerical models that can model their behaviour have been developed so far. For detailed modelling of connections between CFT columns and beam, 3D solid models can be used. However, when modelling whole structures, this model is unacceptable due to its low numerical efficiency. Therefore, when modelling larger structures, frame finite elements are still primarily used.

In this work, modelling of square CFT columns is done using distributed plasticity force based fiber beam/column elements [2], that were proven as very efficient and reliable when used for modelling steel, reinforced concrete and composite structures [1], [2].

In this element, a certain number of cross sections are being monitored along the element axis. Also, cross section discretization is done for each of the monitored cross-sections; they are discretized into a number of integration points (fibers). A corresponding uniaxial material model is assigned to each of the integration points (fibers) (Figure 2). The section response (the section stiffness matrix K_S and the section resisting forces) is obtained through integration over the cross section (1), (2).

$$s = \begin{bmatrix} N \\ M_z \\ M_y \end{bmatrix} = \sum_{i=1}^N \begin{bmatrix} 1 \\ -y_i \\ z_i \end{bmatrix} \cdot \sigma_i \cdot A_i \quad (2)$$

gde je K_s – matrica krutosti poprečnog preseka, a s – sile u preseku.

where K_s - stiffness matrix of the cross section, and s – section forces.

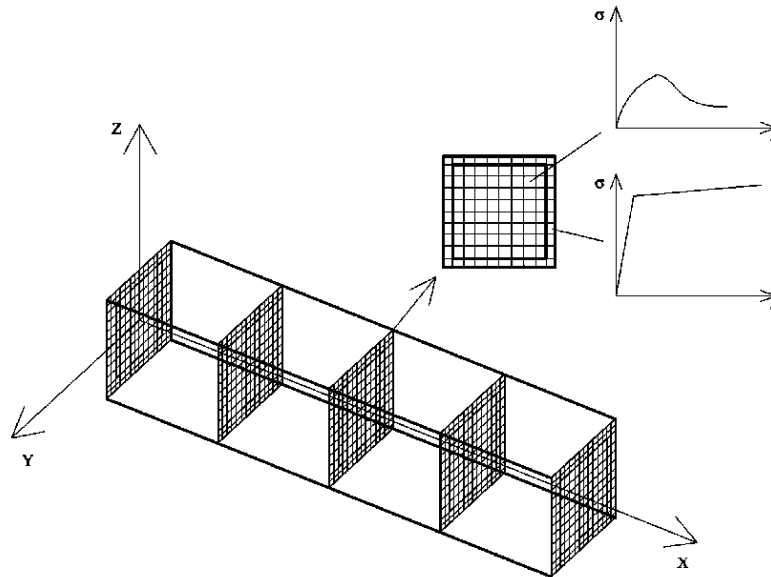

Slika 2. Konačni element s pet tačaka integracije duž ose
Figure 2. Finite element with five points of integration along the axis

Fiber konačni element korišćen u ovom radu definisan je metodom sila. Prednost ovako formulisanog fiber elemenata jeste to što je nelinearno ponašanje CFT stuba moguće aproksimirati manjim brojem konačnih elemenata (jedan element ili dva elementa po dužini stuba), s nekoliko tačaka integracije duž ose elementa. Takođe, uticaj raspodeljenog opterećenja lako se može uzeti u obzir [11].

Geometrijske nelinearnosti su uzete u obzir primenom korotacione formulacije [12].

Kod fiber elemenata, naponi se dobijaju iz dilatacija pomoću prethodno definisanih konstitutivnih veza koje su jednoosne. Uticaj višeosnih stanja napona ima se u vidu indirektno, korekcijom relacija za jednoosna stanja napona. Korišćeni su modeli materijala dostupni u programu *OpenSees* [13], u kom je urađena numerička analiza.

Za modeliranje čeličnog dela preseka korišćeni su sledeći modeli materijala: bilinearni model s kinematičkim ojačanjem i *Giuffré-Menegotto-Pinto* model sa izotropnim ojačanjem. Za modeliranje betonskog dela preseka, korišćeni su *Kent-Scott-Park* model, *Popov* model i *Chang-Mander*-ov model sa uzimanjem u obzir čvrstoće betona na zatezanje i bez toga. Na osnovu detaljne parametarske analize [14], zaključeno je da se najbolje poklapanje sa eksperimentima dobija u modelima sa *Giuffré-Menegotto-Pinto* modelom materijala sa izotropnim ojačanjem (Slika 3) za čelični deo preseka i *Chang-Mander* modelom materijala (Slika 4) za betonski deo preseka. Pored toga, parametarska analiza pokazala je i to da je - u slučaju monotonomog

Force based formulated fiber beam/column elements are used in this work. The main advantage of the force formulation is that nonlinear behaviour of CFT column can be approximated by less number of finite elements (one or two elements per length of the column) with few integration points along the axis of the finite element. In addition, distributed element loading can easily be included into the formulation [11].

Nonlinear geometry is taken into account using the corotational beam formulation [12].

Stresses in fiber elements are obtained from strains, using previously defined constitutive relations. All stress-strain models are uniaxial, while space stress conditions are approximated indirectly, using the modified uniaxial stress-strain relations. The computer program "*OpenSees*" [13] is used for all numerical simulations and stress-strain material models available in this program are used for numerical models.

Behaviour of steel in the cross section was modelled using: bilinear model with kinematic hardening and *Giuffré-Menegotto-Pinto* model with isotropic hardening. For the concrete part of the cross section *Kent-Scott-Park's* model, *Popov's* model and *Chang-Mander's* model were used. In addition, the results are compared when the tensile strength of concrete is included in the material model and when it is neglected. Detailed parametric study is conducted [14] and it is concluded that *Giuffré-Menegotto-Pinto's* model with isotropic hardening for steel (Figure 3) and *Chang-Mander's* model (Figure 4) for concrete are the most appropriate material models in the numerical modelling.

statičkog opterećenja - uticaj čvrstoće betona na zatezanje zanemarljiv pri određivanju granične nosivosti. Naime, u svim testovima, razlika numerički dobijene granične sile - ukoliko je modelirana čvrstoća betona na zatezanje i numerički dobijene granične sile kada je čvrstoća betona na zatezanje zanemarena - bila je manja od 0.25%. Stoga, u narednoj analizi, prilikom provere numeričkog modela, ova čvrstoća je zanemarena. U slučaju cikličnog ili dinamičkog opterećenja, trebalo bi uraditi dodatne analize. Stav većine istraživača jeste da se ova čvrstoća može zanemariti pri određivanju granične nosivosti CFT stubova, nezavisno od vrste opterećenja [15], [16].

Osnovni parametri *Giuffré-Menegotto-Pinto* modela (Slika 3) jesu granica razvlačenja f_y , modul elastičnosti E_s i parametar b koji predstavlja odnos početnog modula elastičnosti i ojačanja. Zakrivljenje na delu između elastičnog i plastičnog dela krive, kao i histerezisno ponašanje čelika definisano je parametrima R_0 , cR_1 , cR_2 čije vrednosti su takođe određene parametarskom analizom.

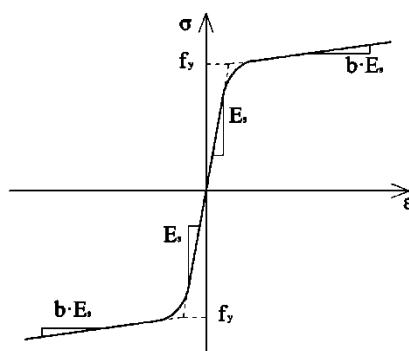

Slika 3. *Giuffré-Menegotto-Pinto* model čelika
Figure 3. *Giuffré-Menegotto-Pinto* steel model

Osnovni parametri *Chang-Mander* modela betona (Slika 4) jesu: čvrstoća utegnutog betona na pritisak f'_c , dilatacija pri maksimalnoj čvrstoći betona na pritisak ϵ'_{c0} , modul elastičnosti betona u elastičnoj oblasti E_c , čvrstoća betona na zatezanje f_t , dilatacija pri maksimalnoj čvrstoći betona na zatezanje ϵ_{ct} , bezdimenzionalni parametar koji definiše krivu modela u oblasti zatezanja x_p , bezdimenzionalni parametar koji definiše krivu modela u oblasti pritiska x_n , parametar koji definiše nelinearnu opadajuću krivu modela r .

Vrednosti navedenih parametara sračunate su na sledeći način. Čvrstoća utegnutog betona na pritisak usvojena je prema preporukama autora eksperimenata [6], [7]. Dilatacija pri maksimalnoj čvrstoći betona sračunata je prema izrazu [17]:

$$\epsilon'_{c0} = \epsilon_{c0} \cdot (1 + 5(C - 1)) \quad (3)$$

gde je C koeficijent koji zavisi od vrste betona i efekta utezanja. Za eksperimente u kojima postoje podaci o koeficijentu C usvojena je data vrednost, dok je u testovima u kojima ovi podaci ne postoje, vrednost koeficijenta C sračunata kao [5]:

Furthermore, it is shown that when samples are exposed to monotonic static load, tensile strength of concrete has little influence on numerical results. In all the samples, difference between ultimate forces, when tensile strength is included in the model and when it is neglected, was smaller than 0.25%. Therefore, in the following evaluation study, tensile strength of concrete is neglected. In the case of cyclic or dynamic loading, this should be further analyzed, although most researchers agree that tensile strength can be neglected when calculating ultimate forces for CFT columns [15], [16] irrespective of loading conditions.

Parameters for defining *Giuffré-Menegotto-Pinto* model (Figure 3) are yield strength f_y , modulus of elasticity E_s and strain-hardening ratio b . Transition curve from elastic to plastic branch and hysteretic behaviour of the model is defined using parameters R_0 , cR_1 , cR_2 . Values of these parameters are obtained through a parametric analysis.

Parameters for defining *Chang-Mander's* model (Figure 4) are: confined compressive strength f'_c , concrete strain at maximum compressive strength ϵ'_{c0} , initial elastic modulus E_c , tensile strength f_t , tensile strain at maximum tensile strength ϵ_{ct} , non-dimensional parameter that defines the strain at which the straight line descent begins in compression x_n , non-dimensional parameter that defines the strain at which the straight line descent begins in tension x_p and parameter that controls the nonlinear descending branch of the concrete model r .

Parameter values are calculated using expression available in the literature. Confined compressive strength is adopted in accordance with the recommendations given in [6], [7]. Concrete strain at maximum compressive strength is given by the following formula [17]:

where coefficient C depends on confinement effect and type of concrete. In experiments where coefficient C is given, that value is used, while in experiments where this value is not reported, it is calculated as [5]:

$$C = \left(1 + \frac{A}{1 + \left(\frac{D/t}{B} \right)^4} \right) \quad (4)$$

$$A = 1.335e^{-\left[\frac{f_c}{24.4} \right]}$$

$$B = 47.49 + \frac{207}{f_c}$$

Dilatacija ε_{c0} određena je prema izrazu [17]

Strain ε_{c0} is given by the equation [17]:

$$\varepsilon_{c0} = \frac{(C \cdot f_c)^{0.25}}{1150} \quad (5)$$

Za vrednost modula elastičnosti betona za uzorke u kojima postoji eksperimentalno dobijena vrednost, korišćena je data vrednost, dok je za uzorke za koje ne postoje podaci o eksperimentalno dobijenoj vrednosti – vrednost modula elastičnosti sračunata prema sledećem izrazu [18]:

In experiments where value for the modulus of elasticity of concrete, obtained experimentally, exists, that value is used, while in experiments where this value is not reported, the modulus of elasticity of concrete is calculated from the following expression [18]:

$$E_c = 8200 \cdot (C \cdot f_c)^{0.375} \quad (6)$$

Parametar koji definiše nelinearnu opadajuću krivu modela r definisan je izrazom [13]:

Parameter that controls the nonlinear descending branch of the concrete model r is defined [13]:

$$r = \frac{n}{n-1} \quad (7)$$

gde je:

Where:

$$n = \frac{E_c \cdot \varepsilon'_{c0}}{C \cdot f_c} \quad (8)$$

Parametri x_n i x_p imaju konstatne vrednosti koje za utegnuti beton unutar čelične cevi iznose: $x_n=30$, $x_p=2$ [13].

Parameters x_n and x_p are constant, and for confined concrete are: $x_n=30$, $x_p=2$ [13].

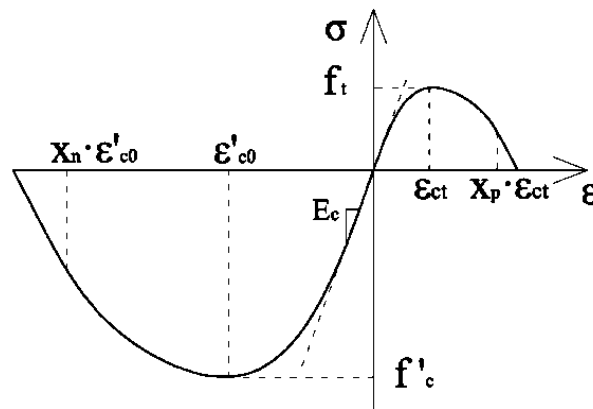

Slika 4. Chang-Mander-ov model betona
Figure 4. Chang-Mander concrete model

5 PROVERA NUMERIČKOG MODELA

Tačnost opisanog numeričkog modela proverena je upoređivanjem numeričkih rezultata sa eksperimentalnim rezultatima dostupnim u literaturi. Eksperimenti korišćeni za proveru modela jesu eksperimenti *Tomii* i *Sakina* [6] i eksperimenti *Bridge*-a [7] na uzorcima izloženim monotono rastućem statičkom opterećenju.

5.1 Eksperimenti Tomii i Sakina [6]

Eksperimenti *Tomii* i *Sakina* [6] vršeni su na prostoj gredi, izloženoj konstantnoj aksijalnoj sili i monotono rastućim momentima na krajevima (Slika 5). Praćene su deformacije grede, tj. obrtanje krajeva grede. Uzorci su kvadratnog poprečnog preseka s različitim debljinama čelične cevi, a geometrijski podaci i vrednost aksijalne sile P u odnosu na aksijalnu nosivost preseka pri pritisku P_0 dati su u Tabeli 1.

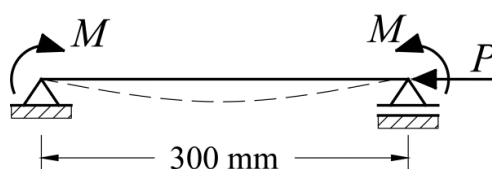

Slika 5. Testovi Tomii i Sakina - dispozicija
Figure 5. Tomii and Sakino experiment disposition

Tabela 1. Geometrijske karakteristike i karakteristike materijala uzoraka
Table 1. Dimensions and material properties of samples

Test	Čelična cev (mm) $D \times B \times t$ Steel tube (mm) $D \times B \times t$	D/t	f'_c [MPa]	f_y [MPa]	P [kN]	P/P_0
II-2	100 x 100 x 2.27	44	25.9	339	93.66	0.18
II-3	100 x 100 x 2.20	44	25.9	339	140.50	0.26
II-5	100 x 100 x 2.22	44	25.9	289	235.15	0.48
II-6	100 x 100 x 2.22	44	25.9	289	281.98	0.57
IV-3	100 x 100 x 4.25	24	22.4	288	188.32	0.29
IV-5	100 x 100 x 4.25	24	23.8	285	318.85	0.48
IV-6	100 x 100 x 4.26	24	23.8	288	381.62	0.57

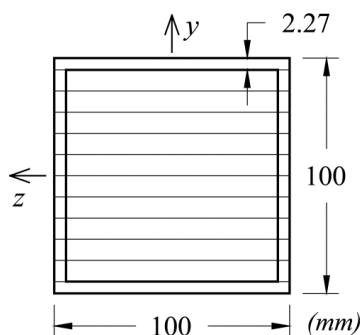

Slika 6. Diskretizacija poprečnog preseka u testovima Tomii i Sakina
Figure 6. Cross-section discretization for Tomii and Sakino experiments

Greda je modelirana s jednim fiber konačnim elementom sa pet tačaka integracije duž ose elementa. Budući da je u ovoj grupi testova poprečni presek izložen savijanju oko jedne ose, vršena je diskretizacija samo u pravcu y ose i betonsko jezgro je diskretizovano s deset slojeva (vlakana) u pravcu y ose, dok je čelična cev diskretizovana s deset slojeva po visini betonskog dela preseka i jednim slojem po debljini čelične cevi (Slika 6). Dalje povećanje broja vlakana nije uticalo na rezultate analize. Kao što je već rečeno, geometrijske nelinearnosti uzete su u obzir primenom korotacione formulacije [12].

Parametri *Chang-Mander*-ovog modela betona, sračunati prema izrazima (3-8) uz vrednost $C=1.2$, prikazani su u Tabeli 2.

Beam was modelled using one fiber element with 5 integration points along the axis of the element. Considering that samples in this experiment are exposed to uniaxial bending, discretization has been done only in the y direction. Concrete core is discretized with 10 fibers along the y axis, while steel tube is discretized with 10 layers through the height of the concrete core and one layer per tube thickness (Figure 6). Further increase in the number of fibres has no influence on the results. Geometrical nonlinearities are taken into account using the corotational formulation [12].

Parameters for *Chang-Mander's* model for concrete shown in Table 2 are calculated using previously defined expressions (3-8), with $C=1.2$.

Tabela 2. Parametri konstitutivnog modela betona

Table 2. Concrete model parameters

Test	ϵ'_{co}	E_c [MPa]	r
II-2	0.00392	27784.42	1.31
II-3	0.00392	27784.42	1.31
II-5	0.00392	27784.42	1.31
II-6	0.00392	27784.42	1.31
IV-3	0.00378	26312.18	1.29
IV-5	0.00384	26917.22	1.30
IV-6	0.00384	26917.22	1.30

Za parametre modela čelika E_y , f_y i b korišćeni su eksperimentalno dobijeni rezultati [6], a za R_0 , cR_1 , cR_2 vrednosti određene parametarskom analizom (Tabela 3): $R_0=15$, $cR_1=0.925$ i $cR_2=0.15$.

For some of steel model parameters (Table 3) experimentally obtained values are used [6] (for E_y , f_y and b), while for other parameters values are obtained through a detailed parametric study: $R_0=15$, $cR_1=0.925$ and $cR_2=0.15$.

Tabela 3. Parametri konstitutivnog modela čelika

Table 3. Steel model parameters

Test	f_y [Mpa]	E_y [MPa]	b
II-2	339	217385	0.007
II-3	339	217385	0.007
II-5	289	215745	0.007
II-6	289	215745	0.007
IV-3	288	225553	0.010
IV-5	285	225553	0.010
IV-6	288	215743	0.010

Slike 7-10 prikazuju poređenje numerički i eksperimentalno dobijenih relacija moment (M) – rotacija kraja grede (φ). Samo kao ilustracija prethodno navedenog zaključka u vezi sa zanemarivanjem čvrstoće betona na zatezanje (f_t), za uzorak II-2, prikazani su

Figures 7-10 show comparison between end moment (M) – end rotation (φ) relations obtained using previously defined numerical model and experimental results. For sample II-2, two diagrams are shown to illustrate the small effect of the modelling of the tensile strength of

numerički rezultati modela sa uzimanjem u obzir čvrstoće betona na zatezanje i bez toga. Kod ostalih uzoraka, prikazani su samo numerički rezultati dobijeni bez uzimanja u obzir ove čvrstoće ($f_t=0$). Vrednosti graničnih momenata nosivosti uzoraka dati su u Tabeli 4. Sračunata srednja vrednost i standardna devijacija za ovu grupu testova potvrđuju visok stepen tačnosti modela za sve nivoe aksijalne sile.

concrete on ultimate capacity. One is when tensile strength is included in the concrete model ($f_t \neq 0$), and the other one is when it is neglected ($f_t = 0$). For other samples, numerical results presented below are obtained not taking into account tensile strength of concrete. Ultimate moment capacities of samples are shown in Table 4. Calculated average and standard deviation for this group of test show high level of accuracy of the numerical model. Also, it is evident that numerical model is very good at describing nonlinear behaviour of CFT columns exposed to constant axial force and monotonically increasing end moments for all P/P_0 ratios.

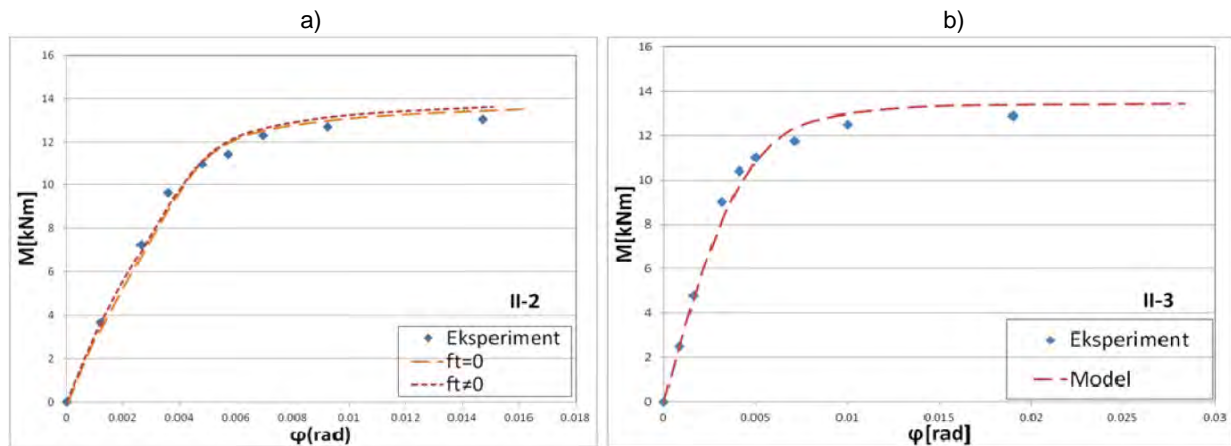

Slika 7. Moment M – rotacija φ dijagram a) test II-2 i b) test II-3
 Figure 7. End moment M - end rotation φ diagram a) test II-2 and b) test II-3

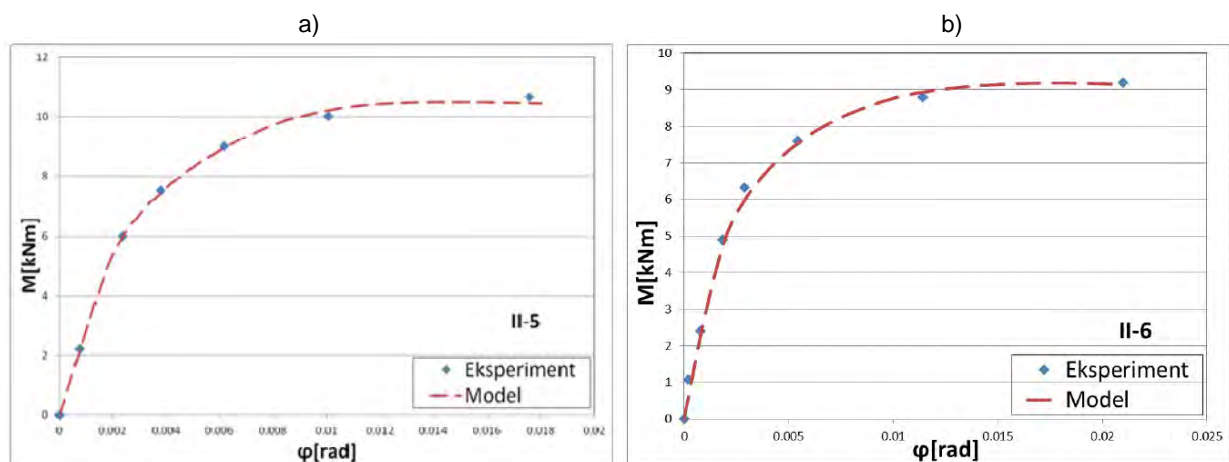

Slika 8. Moment M – rotacija φ dijagram a) test II-5 i b) test II-6
 Figure 8. End moment M - end rotation φ diagram a) test II-5 and b) test II-6

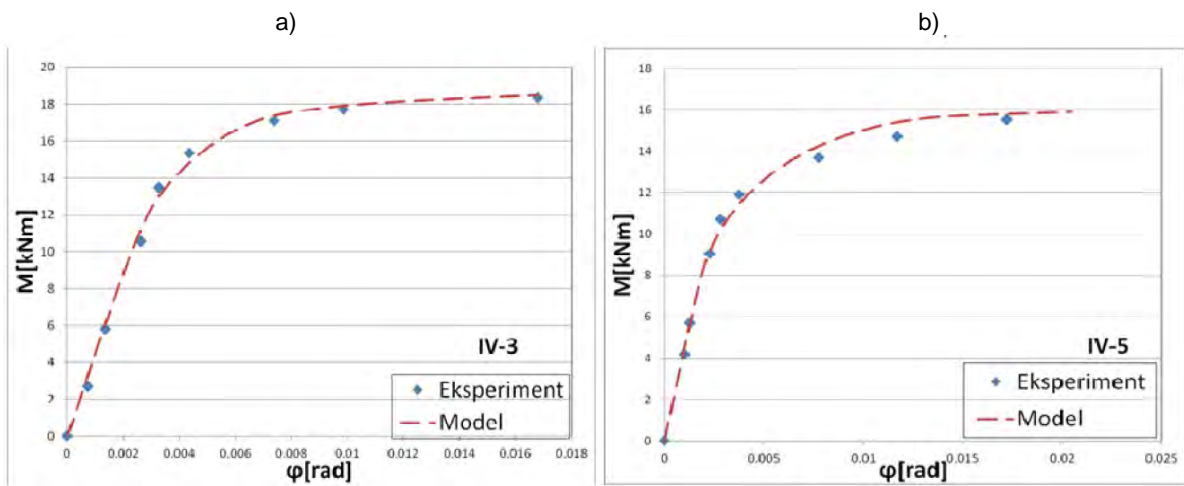

Slika 9. Moment M – rotacija φ dijagram a) test IV-3 i b) test IV-5
 Figure 9. End moment M - end rotation φ diagram a) test IV-3 and b) test IV-5

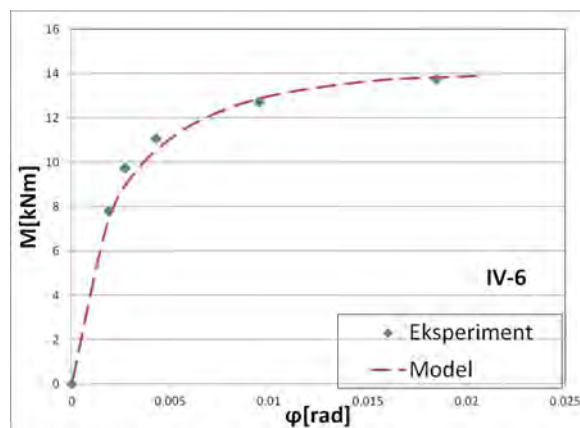

Slika 10. Moment M – rotacija φ dijagram, test IV-6
 Figure 10. End moment M - end rotation φ diagram test IV-6

Tabela 4. Poređenje numeričkih i eksperimentalnih rezultata
 Table 4. Numerical and experimental results

Test	$M_{u,exp}$ [kNm]	$M_{u,num}$ [kNm]	$M_{u,exp}/M_{u,num}$
II-2	13.03	13.3	0.98
II-3	12.9	13.25	0.97
II-5	10.66	10.43	1.02
II-6	9.2	9.15	1.01
IV-3	18.4	18.4	1.00
IV-5	15.51	15.68	0.99
IV-6	13.73	13.8	0.99
Srednja vrednost Average			0.99
St. dev			0.03

5.2 Eksperimenti Bridge-a [7]

Eksperimenti *Bridge-a* [7] vršeni su na prostoj gredi izloženoj ekscentričnoj monotono rastućoj sili pritiska N (Slika 11). U ovoj grupi testova, ispitivan je uticaj vitkosti, ekscentriciteta sile N i kosog savijanja na nelinearno ponašanje CFT stubova.

5.2 Bridge experiment[7]

Bridge experiment [7] is conducted on a simply supported beam exposed to eccentric axial force (Figure 11). Axial compressive force N is monotonically increasing, while the mid-span deflection is being monitored. In this group of tests, the effects of loading eccentricity, column slenderness and biaxial bending on nonlinear behaviour of CFT columns are studied.

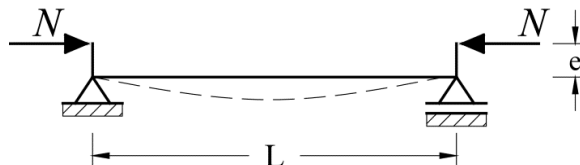

Slika 11. Testovi Bridge-a – dispozicija
Figure 11. Bridge experiment disposition

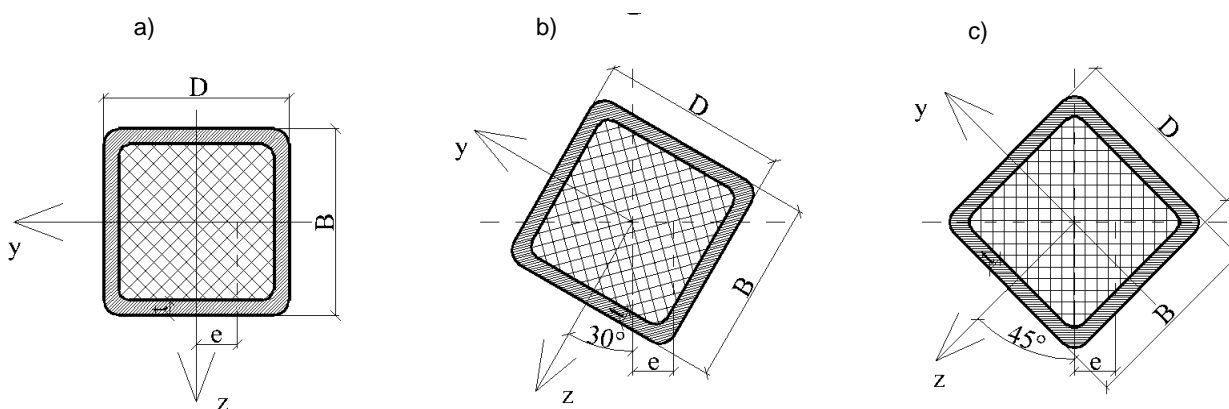

Slika 12. Orijentacija poprečnog preseka uzoraka a) SHC-1, SHC-7, SHC-8; b) SHC-3, SHC-5 i c) SHC-4, SHC-6
Figure 12. Orientation of cross-section for samples a) SHC-1, SHC-7, SHC-8; b) SHC-3, SHC-5 and c) SHC-4, SHC-6

Tabela 5. Podaci o dispoziciji eksperimenta i dimenzijama uzoraka
Table 5. Geometrical properties for Bridge experiment

Test	Čelična cev (mm) $D \times B \times t$ Steel tube (mm) $D \times B \times t$	D/t	L [m]	α (°)	e (mm)
SHC-1	203.7 x 203.9 x 9.96	20	2.13	0	38
SHC-3	203.3 x 202.8 x 10.03	20	2.13	30	38
SHC-4	202.8 x 203.4 x 9.88	20	2.13	45	38
SHC-5	202.6 x 203.2 x 10.01	20	3.05	30	38
SHC-6	203.2 x 202.1 x 9.78	20	3.05	45	64
SHC-7	152.5 x 152.3 x 6.48	23.5	3.05	0	38
SHC-8	152.5 x 152.3 x 6.48	23.5	3.05	0	64

Geometrijski podaci o uzorcima su prikazani u Tabeli 5, sa oznakama veličina prikazanim na slici 12.

Geometrical properties of samples are given in Table 5, while Figure 12 depicts the meaning of parameters e (eccentricity) and α (angle).

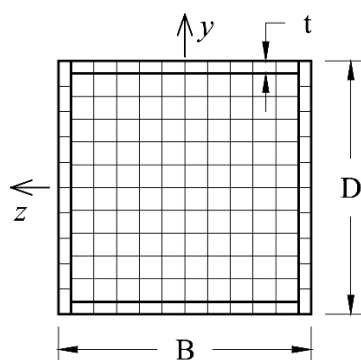

Slika 13. Diskretizacija poprečnog preseka u testovima Bridge-a
Figure 13. Cross-section discretization for Bridge experiments

Greda je modelirana sa dva konačna elementa s tri tačke integracije duž ose elementa. Budući da je u nekim testovima poprečni presek izložen savijanju oko obe ose, izvršena je diskretizacija poprečnog preseka i u y i u z pravcu sa ukupno 140 tačaka diskretizacije (za betonski deo preseka 100 tačaka integracije, za čelični deo preseka 40 tačaka diskretizacije [Slika 13]).

S obzirom na to što je u svim ispitivanim uzorcima ove grupe testova odnos e/D bio veći od 0.125, kao što je objašnjeno u delu 3, u numeričkom modelu zanemareno je povećanje čvrstoće betona pri pritisku, tj. usvojeno je da je $f'_c = f_c$. Ostali parametri modela materijala sračunati su prema izrazima (3)-(8) i njihove vrednosti date su u Tabeli 6. Parametar b ima vrednost 0.025.

Beam was modelled with two fiber elements with three integration points along the element axis. Considering that beam is exposed to biaxial bending, the discretization was done along both y and z directions. Total number of cross section integration points (fibers) is 140 (100 fibers for concrete core and 40 fibers for steel tube) (Figure 13).

The increase of compressive strength due to confinement for these samples was neglected, because e/D ratio was higher than 0.125, as explained in section 3. Remaining material model parameters are calculated using expressions (3-8) and their values are shown in Table 6. Parameter b has a value of 0.025

Tabela 6. Parametri konstitutivnih modela materijala
Table 6. Parameters for models of materials

Test	f'_c [MPa]	ϵ'_{c0}	E_c [MPa]	r	f_y [MPa]	E_y [GPa]
SHC-1	30.2	0.00641	23300	1.39	291	205
SHC-3	34.5	0.00585	26410	1.42	313	205
SHC-4	33.1	0.00603	27850	1.36	317	205
SHC-5	37.8	0.00548	28330	1.45	319	205
SHC-6	32.1	0.00615	27090	1.35	317	205
SHC-7	35.0	0.00573	24060	1.50	254	205
SHC-8	35.0	0.00573	24060	1.50	254	205

Slike 14-17 prikazuju poređenje numerički i eksperimentalno dobijenih relacija aksijalna sila (N) - vertikalno pomeranje na sredini raspona (v). Granične vrednosti aksijalne sile su date u Tabeli 7. Kao i u prethodnoj grupi testova, srednja vrednost i standardna devijacija potvrđuju visoku tačnost predloženog numeričkog modela. Najveće odstupanje numerički i eksperimentalno dobijenih rezultata je kod uzoraka SHC-7 i SHC-8 koji imaju najveću vitkost. Odnos L/D kod ovih uzoraka jeste 20, odnosno, veći je od 15. Kao što je objašnjeno u uvodnom delu, u ovim slučajevima stabilnost nosača dominantno određuje njegovo ponašanje, što dati numerički model ne uzima u obzir i što će biti predmet naknadne analize. Kod ostalih uzoraka, granična sila određena je s greškom manjom od 7%.

Figures 14-17 show numerically and experimentally obtained relations between axial force (N) - vertical mid-section displacement (v). Numerically and experimentally obtained values of ultimate axial forces are shown in Table 7. As with previous group of test, average value and standard deviation confirm the ability of the proposed numerical model to approximate well the nonlinear behaviour of CFT columns exposed to eccentric axial force. Larger differences between numerical and experimental results are observed in samples with higher slenderness such as SHC-7 and SHC-8. Ratio L/D for these samples is 20, i.e. higher than 15. As was explained in introduction, in these cases stability of CFT column dominantly governs the behaviour of the sample. In proposed numerical model, this is not considered and will be a subject of future study. In other samples,

ultimate axial force obtained numerically differs from experimental results by 7% at most.

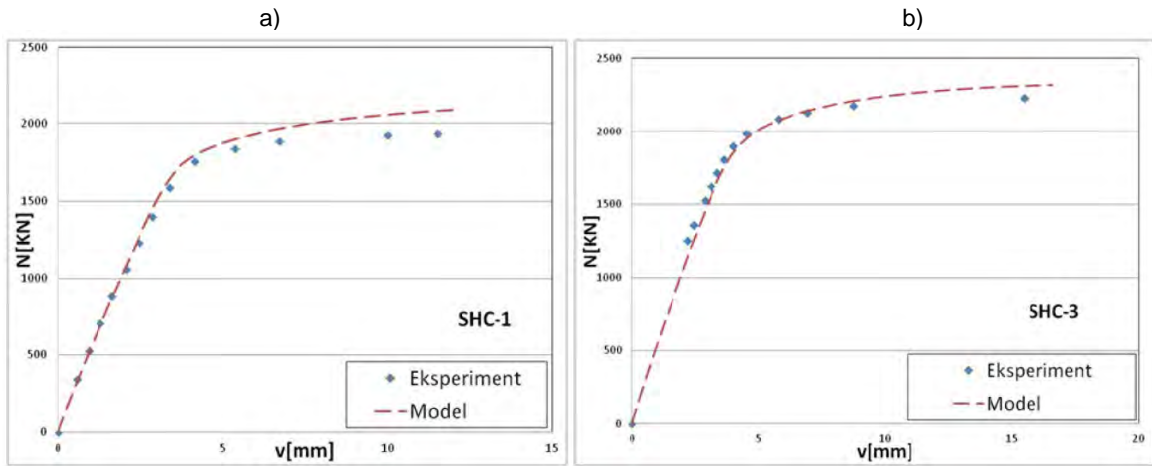

Slika 14. Aksijalna sila N – pomeranje v dijagram a) test SHC-1 i b) test SHC-3

Figure 14. Axial force N - mid-section displacement v diagram a) test SHC-1 and b) test SHC-3

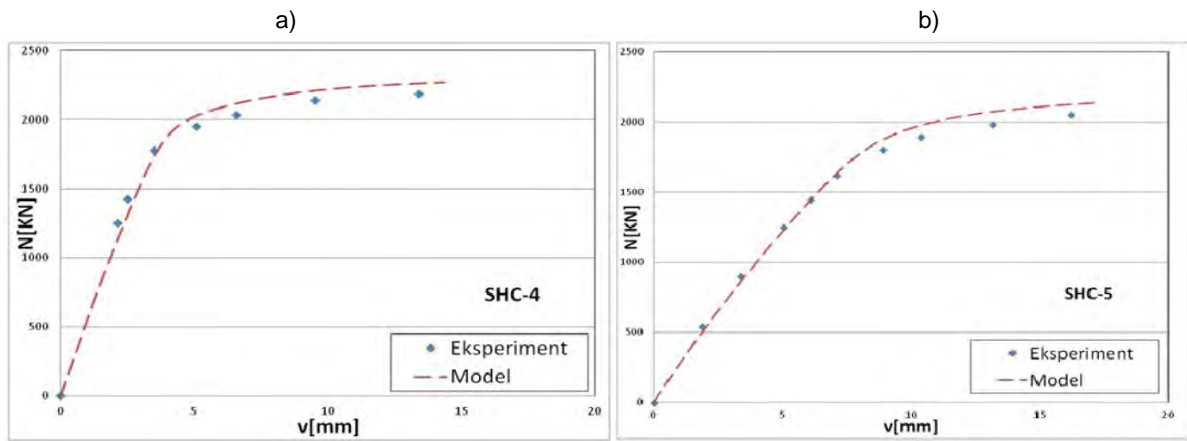

Slika 15. Aksijalna sila N – pomeranje v dijagram a) test SHC-4 i b) test SHC-5

Figure 15. Axial force N - mid-section displacement v diagram a) test SHC-4 and b) test SHC-5

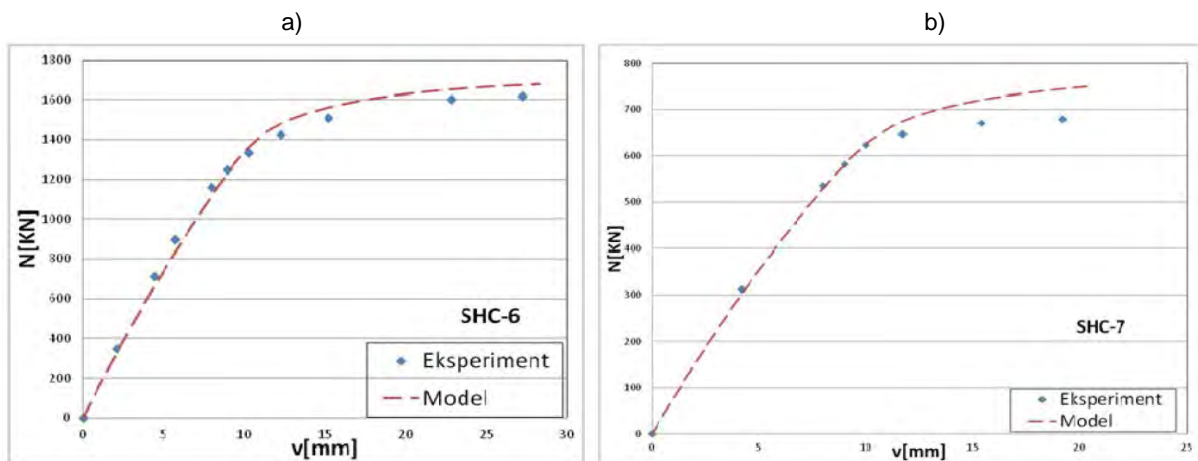

Slika 16. Aksijalna sila N – pomeranje v dijagram a) test SHC-6 i b) test SHC-7

Figure 16. Axial force N - mid-section displacement v diagram a) test SHC-6 and b) test SHC-7

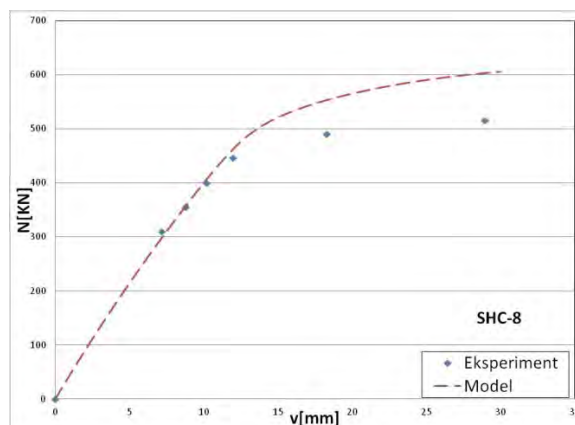

Slika 17. Aksijalna sila N – pomeranje v dijagram test SHC-8

Figure 17. Axial force N - mid-section displacement v diagram test SHC-8

Tabela 7. Poređenje numeričkih i eksperimentalnih rezultata za graničnu vrednost sile N

Table 7. Numerical and experimental results

Test	$N_{u,exp}$ [kN]	$N_{u,num}$ [kN]	$N_{u,exp}/N_{u,num}$
SHC-1	1939.7	2081.2	0.93
SHC-3	2229.8	2314.1	0.96
SHC-4	2188.5	2263.7	0.97
SHC-5	2050.3	2147.3	0.95
SHC-6	1619.9	1671.6	0.97
SHC-7	678.8	744.2	0.91
SHC-8	515.9	603.5	0.85
Srednja vrednost Average			0.94
St. dev.			0.04

6 ZAKLJUČAK

U radu je predložen numerički model za nelinearnu analizu kvadratnih CFT stubova, primenom fiber elementa raspodeljene plastičnosti. Modelom su prikazani sledeći uticaji: nelinearno ponašanje betona i čelika primenom odgovarajućih konstitutivnih relacija, efekat utezanja betona i geometrijske nelinearnosti. Model zanemaruje lokalno izbočavanje čeličnog dela preseka, rezidualne napone prisutne u čeličnom delu preseka i viskozne deformacije betona.

Za modeliranje čeličnog i betonskog dela preseka CFT stuba analizirani su različiti konstitutivni modeli materijala. Parametarskom analizom utvrđeno je da se najmanja odstupanja od eksperimentalno dobijenih rezultata dobijaju primenom *Giuffré-Menegotto-Pinto* modela za čelični deo preseka i *Chang-Mander* modela za betonski deo preseka. Zatim, poređenjem sa eksperimentalnim rezultatima testova *Tomii* i *Sakina* i *Bridge-a*, izvršena je evaluacija tako definisanog numeričkog modela. U ovim testovima stubovi su bili izloženi

6 CONCLUSION

In this work, a numerical model for nonlinear analysis of square CFT columns using distributed plasticity fiber finite element is proposed. Numerical model presented in this work takes into consideration: nonlinear behaviour of concrete and steel using nonlinear material models, confinement effect and geometrical nonlinearities. Local buckling of steel tube, residual stresses and viscous characteristics of concrete are not considered.

For modelling of steel and concrete parts of the cross section various material models are analysed. Parametric study is conducted and it is concluded that the best agreement between numerical and experimental results is achieved using *Giuffré-Menegotto-Pinto* model for steel and *Chang-Mander* model for concrete. Afterwards, validation of such numerical model is done by comparing numerical and experimental results of CFT columns exposed to proportional and non-proportional monotonically increasing loading. Based on numerical results it can be concluded

statičkom, monotono rastućem opterećenju. Na osnovu dobijenih rezultata, može se zaključiti da predloženi numerički model karakteriše visok stepen tačnosti u nelinearnoj analizi kvadratnih CFT stubova pri statičkom opterećenju.

ZAHVALNOST:

Drugi autor zahvaljuje Ministarstvu nauke Republike Srbije za finansijsku podršku u okviru projekta TR 36046.

7 LITERATURA REFERENCE

- [1] Hajjar JF, Molodan A, Schiller PH, A distributed plasticity model for cyclic analysis of concrete-filled steel tube beam-columns and composite frames., *Eng. Struct.* 20 4-6398-412 Doi 101016s0141-02969700020-5, 1998.
- [2] Spacone E, Filippou FC, Taucer FF, Fiber Beam-Column Model for Nonlinear Analysis of RC Frames, *Appl. Earthq. Eng. Struct. Dyn.* 25 7727-742, 1996.
- [3] L. Vlajić and A. Landović, Strengthening of reinforced concrete columns coupled with steel tubes, *Gradjevinski Materijali Konstr.*, vol. 53, no. 4, pp. 39–49, 2010.
- [4] Lazović M., Radovanović J, and Deretić-Stojanović B, Bearing capacity and stability of elastically fixed CFT columns, *Tech. Gaz. Portal Sci. J. Croat. Hrčak Osijek*, 2016.
- [5] H. R. Valipour and S. J. Foster, Nonlinear static and cyclic analysis of concrete-filled steel columns, *J. Constr. Steel Res.*, vol. 66, no. 6, pp. 793–802, Jun. 2010.
- [6] Masahide Tomii and Kenji Sakino, Experimental Studies on the Ultimate Moment of Concrete Filled Square Steel Tubular Beam-Columns, Jan. 1979.
- [7] Bridge RQ, Concrete filled steel tubular columns, Rep. No R283Sydney Aust. Sch. Civ. Eng. Univ. Syd., 1976.
- [8] Robert Park and Robert B. Knowles, Axial Load Design for Concrete Filled Steel Tubes, *J. Struct. Div.* 1970 Vol 96 Issue 10 Pg 2125-2153.
- [9] B. C. Gourley, C. Tort, M. D. Denavit, P. H. Schiller, and J. F. Hajjar, A synopsis of studies of the monotonic and cyclic behavior of concrete-filled steel tube members, connections, and frames, Newmark Structural Engineering Laboratory. University of Illinois at Urbana-Champaign., 2008.
- [10] B. C. Gourley and J. F. Hajjar, *Cyclic Nonlinear Analysis of Concrete-filled Steel Tube Beam-columns and Composite Frames*, 1994.
- [11] S. Kostic and B. Deretic-Stojanovic, Fiber element formulation for inelastic frame analysis, *Gradjevinski Materijali Konstr.*, vol. 59, no. 2, pp. 3–13, 2016.
- [12] M. A. Crisfield, *Non-linear finite element analysis of solids and structures*. Chichester ; New York: Wiley, 1991.
- [13] McKenna, Frank, G. L. Fenves, and M. H. Scott, *Open system for earthquake engineering simulation.*, Univ. Calif. Berkeley CA, 2000.
- [14] Nikola Blagojevic, *Nonlinear analysis of frames with CFT columns*, MSc Thesis, Faculty of Civil Engineering, Belgrade, 2016.
- [15] J. M. Portolés, M. L. Romero, F. C. Filippou, and J. L. Bonet, Simulation and design recommendations of eccentrically loaded slender concrete-filled tubular columns, *Eng. Struct.*, vol. 33, no. 5, pp. 1576–1593, May 2011.
- [16] A. H. Varma, R. Sause, J. M. Ricles, and Q. Li, Development and validation of fiber model for high-strength square concrete-filled steel tube beam-columns, *ACI Struct. J.*, vol. 102, no. 1, p. 73, 2005.
- [17] M. D. Denavit and J. F. Hajjar, Characterization of behavior of steel-concrete composite members and frames with applications for design, Newmark Structural Engineering Laboratory. University of Illinois at Urbana-Champaign., 2014.
- [18] Chang, G.A and Mander, J.B, Seismic Energy Based Fatigue Damage Analysis of Bridge Columns: Part 1 – Evaluation of Seismic Capacity, NCEER Tech. Rep. No NCEER-94-0006 State Univ. N. Y. Buffalo N, 1994.

REZIME

FIBER KONAČNI ELEMENT U NELINEARNOJ ANALIZI KVADRATNIH SPREGNUTIH CFT STUBOVA

Nikola BLAGOJEVIĆ
Svetlana M. KOSTIĆ
Saša STOŠIĆ

U radu je prikazana nelinearna analiza kvadratnih CFT stubova, pomoću fiber konačnog elemenata raspodeljene plastičnosti. CFT stubove karakteriše nelinearno ponašanje, što je potrebno imati u vidu u numeričkom modelu. Model predložen u ovom radu uzima u obzir sledeće nelinearne uticaje: nelinearno ponašanje betona i čelika primenom odgovarajućih konstitutivnih relacija, efekat utezanja betona i geometrijske nelinearnosti. Analizirani su uzorci izloženi delovanju statičkog opterećenja koji imaju različitu vitkost, odnos D/t (odnos ukupne dimenzije čeličnog profila $[D]$ i debljine čeličnog profila $[t]$), kao i uzorci izloženi različitim tipovima naprezanja. Na osnovu parametarske analize, određeni su modeli materijala za čelik i beton, kao i njihovi parametri koji najbolje aproksimiraju ponašanje CFT stubova. Tačnost modela proverena je zatim i upoređivanjem sa eksperimentalnim podacima dostupnim u literaturi.

Ključne reči: fiber konačni element, CFT stub, nelinearna analiza

SUMMARY

FIBER FINITE ELEMENT IN NONLINEAR ANALYSIS OF SQUARE CFT COLUMNS

Nikola BLAGOJEVIC
Svetlana M. KOSTIC
Sasa STOSIC

The paper presents nonlinear analysis of square CFT columns using distributed plasticity fiber elements. Behaviour of CFT columns is nonlinear and it is necessary to include different nonlinear effects into the numerical model in order to simulate their behaviour properly. Model proposed in this work considers: nonlinear behaviour of concrete and steel using nonlinear stress-strain models, confinement effect and geometrical nonlinearities. Tests exposed to static loading with different slenderness, different D/t ratio (where D is the total dimension of a cross section and t is the thickness of steel tube) and different loading conditions are analyzed. Stress-strain models that best approximate the behaviour of CFT columns are determined from a detailed parametric study. The proposed numerical model is validated by comparing numerical with experimental results available in the literature.

Key words: fiber beam/column element, CFT column, nonlinear analysis

OJAČANJE DRVENIH GREDA PRIMENOM FRP ŠIPKI

STRENGTHENING OF TIMBER BEAMS USING FRP BARS

Marija TODOROVIĆ
Boško STEVANOVIĆ
Ivan GLIŠOVIĆ

PREGLEDNI RAD
REVIEW PAPER
UDK:624.011.1.072.2
666.94
doi:10.5937/grmk1701047T

1 UVOD

Drvo kao jedan od najstarijih građevinskih materijala nalazi primenu i u savremenoj građevinskoj praksi zahvaljujući tome što predstavlja prirodan, obnovljiv, biorazgradiv i estetski atraktivan materijal. Potreba da se ojačaju drvene konstrukcije može nastati iz različitih razloga, kao što su mehanička oštećenja, destruktivni uticaji okruženja ili povećanje korisnog opterećenja. U ovom kontekstu, razvoj efikasnih metoda ojačanja od velike je važnosti.

Poslednjih godina, primena polimera ojačanih vlaknima (*Fiber Reinforced Polymer* - FRP) u oblasti sanacija i ojačanja građevinskih konstrukcija omogućena je zahvaljujući povećanoj dostupnosti i sve nižoj ceni. FRP materijali su grupa naprednih kompozita u okviru kojih se nalaze vlakna izraženih mehaničkih karakteristika (najčešće staklena ili karbonska) povezana izuzetno čvrstom, hemijski otpornom i trajnom sintetičkom smolom (kao matricom). Ovi kompozitni materijali dostupni su kao gotovi fabrički proizvodi najčešće u formi traka, tkanina ili šipki. Povezivanje FRP ojačanja za konstrukcijske elemente izvodi se uglavnom lepljenjem uz primenu odgovarajućih polimernih lepkova. Ovi materijali se već dugo uspešno koriste pri ojačanju betonskih i zidanih konstrukcija [1,2], dok je njihova primena za ojačanje i sanaciju drvenih konstrukcija još uvek u fazi ispitivanja kako bi se obezbedila pravilna i optimalna

1 INTRODUCTION

Timber, as one of the oldest structural materials, is still widely used nowadays since it is natural, renewable, biodegradable and aesthetically attractive material. The need for reinforcement of timber structures can be caused by various reasons, such as mechanical damage, destructive effects of the environment or the increase in service loads. Therefore, the development of effective methods of reinforcement is of great importance.

In recent years, the use of Fibre Reinforced Polymers - FRP in the field of repair and strengthening of structures was made possible thanks to the increased availability and lower price. FRP materials are a group of advanced composites comprised of fibres with high mechanical properties (usually glass or carbon fibres) embedded in chemically resistant and durable synthetic resin (as a matrix). These composites are available as finished products, usually in the form of plates, sheets or bars. Bonding of FRP reinforcement to structural elements is mainly performed by gluing with suitable polymer adhesives. In the past years composite materials have been successfully used for the reinforcement of concrete and masonry structures [1,2], while their application for the reinforcement and repair of timber structures is still in the experimental phase in order to ensure their proper and optimal use. FRP com-

Marija Todorović, Asistent - student doktorskih studija, mast. inž. građ., Građevinski fakultet Univerziteta u Beogradu, Beograd, todorovicm@grf.bg.ac.rs
Boško Stevanović, Redovni profesor, dr, dipl. inž. građ., Građevinski fakultet Univerziteta u Beogradu, Beograd, bole@imk.grf.bg.ac.rs
Ivan Glišović, docent, dr, dipl. inž. građ, Građevinski fakultet Univerziteta u Beogradu, Beograd, ivang@imk.grf.bg.ac.rs

Marija Todorovic, Teaching assistant, MSc, Faculty of Civil Engineering, University of Belgrade, Republic of Serbia, todorovicm@grf.bg.ac.rs
Bosko Stevanovic, Professor, PhD, Faculty of Civil Engineering, University of Belgrade, Republic of Serbia, bole@imk.grf.bg.ac.rs
Ivan Glisovic, Assistant professor, PhD, Faculty of Civil Engineering, University of Belgrade, Republic of Serbia, ivang@imk.grf.bg.ac.rs

upotreba. FRP kompoziti su idealno ojačanje za drvene elemente zbog njihovih izuzetnih karakteristika, kao što su odlična mehanička svojstva, mala sopstvena težina, izuzetna trajnost, velika mogućnost oblikovanja i fleksibilnost.

U radu je predstavljena upotreba FRP šipki kao materijala za ojačanje drvenih nosača. Postavljanje FRP šipki unutar poprečnog preseka nosača ima nekoliko značajnih prednosti u odnosu na uobičajenu primenu FRP traka sa spoljne strane preseka, kao što su: veća sigurnost pri požaru, bolja estetska svojstva, efikasnija veza drvo-FRP (veća površina lepljenja) i smanjena mogućnost pojave delaminacije ojačanja.

2 FRP KOMPOZIT

Zavisno od zahtevanih fizičkih i mehaničkih karakteristika, kao i od ekonomskih razmatranja, FRP kompoziti mogu biti sačinjeni od različitih tipova vlakana i polimernih matrica, i prilagođeni tako da obezbede potrebnu nosivost i krutost u željenim pravcima. U okviru kompozita vlakna i matrica zadržavaju svoj fizički i hemijski identitet, a ipak zajedno proizvode određena svojstva koja ne mogu biti dostignuta kada deluju samostalno.

2.1 Vlakna

Izbor vlakana umnogome utiče na karakteristike kompozita. Za primenu u građevinarstvu dominiraju tri tipa veštačkih vlakana: karbonska, staklena i aramidna, a u poslednje vreme primenu nalaze i prirodna bazaltna vlakna. Vlakna imaju različite karakteristike, uključujući i cenu, što čini jednu vrstu više pogodnom od druge vrste za različite namene. Sva vlakna imaju generalno veliki kapacitet nosivosti (veći od običnog čelika) i linearno elastično ponašanje do loma. U tabeli 1 su prikazane osnovne karakteristike vlakana.

Staklena vlakna imaju dobre mehaničke karakteristike, visoku hemijsku otpornost i odlična izolaciona svojstva uz nisku cenu u odnosu na druge tipove vlakana. Nedostaci ovih vlakana jesu relativno nizak modul elastičnosti, mala otpornost na zamor, osetljivost na habanje i na vlagu, kao i sklonost ka deformacijama tečenja.

Karbonska vlakna imaju visoke mehaničke karakteristike u pravcu vlakana i znatno niže u poprečnom pravcu. Prednosti karbonskih vlakana jesu dobar odnos između čvrstoće i težine, odlična trajnost, dobra reološka svojstva, otpornost na zamor. Najveći nedostatak karbonskih vlakana jeste njihova cena.

Aramidna vlakna imaju najmanju zapreminsku masu i najveću čvrstoću na zatezanje naspram zapreminske mase u poređenju sa staklenim i karbonskim vlaknima. Kompoziti sa aramidnim vlaknima imaju dobru otpornost na dinamička i udarna opterećenja. Aramidna vlakna imaju visoku termičku stabilnost i dobru hemijsku otpornost. Mane aramidnih vlakana jesu nepostojanost na povišenim temperaturama, kao i osetljivost na vlažnost i UV zračenje.

Bazaltna vlakna imaju odličnu otpornost na koroziju i hemijske uticaje. Po svom ponašanju najbližnja su staklenim vlaknima, pa se često koriste kao zamena za njih. Najveća prednost ovog tipa vlakana jeste u tome

posites are the perfect reinforcement for timber elements due to their exceptional characteristics, such as excellent mechanical properties, low weight, good durability, availability in different shapes and flexibility.

The paper presents the use of FRP bars as reinforcement materials for timber beams. Placing the FRP bars within a cross-section of the beams has several important advantages over traditional use of FRP plates on the outer sides of the beams, such as greater fire safety, better aesthetic appearance, more efficient timber-FRP bond (greater gluing surface) and decreased possibility of delamination.

2 FRP COMPOSITES

Depending on the required physical and mechanical properties, as well as economic factors, FRP composites can be made from various types of fibres and polymer matrices and they can be adapted to provide the required load carrying capacity and stiffness in desired directions. Within the composite, fibres and matrices keep their physical and chemical identity, yet together they produce certain properties that cannot be achieved when they are used separately.

2.1 Fibres

The choice of fibres greatly affects the characteristics of the composite. In civil engineering three types of fibres are mainly used: carbon, glass and aramid; lately the natural basalt fibres are also applied. The fibres have different properties and prices, which makes one type more suitable than the other for different purposes. All fibres generally have a large load carrying capacity (greater than steel) and linear elastic behaviour up to failure. Table 1 shows the main fibre properties.

Glass fibres have good mechanical properties, high chemical resistance, excellent insulating properties and low cost compared to other types of fibres. Disadvantages of these fibres are relatively low modulus of elasticity, low fatigue resistance, sensitivity to abrasion and moisture, as well as tendency to creep deformations.

Carbon fibres have high mechanical properties in fibre direction and much lower in transverse direction. The advantages of carbon fibres are good strength to weight ratio, excellent durability, good rheological properties and fatigue resistance. The greatest disadvantage of carbon fibres is their price.

Aramid fibres have the lowest weight and the highest tensile strength to weight ratio compared to glass and carbon fibres. Composites with aramid fibres have good resistance to dynamic and impact loads. Aramid fibres have high thermal stability and good chemical resistance. Main flaws of aramid fibres are sensitivity to high temperatures, moisture and UV radiation.

Basalt fibres have excellent resistance to corrosion and chemical influences. These fibres are most similar to glass fibres and are often used as a substitute for them. The biggest advantage of basalt fibres is that they are natural material and therefore the negative impacts on the environment during production and use of these fibres are reduced to minimum.

što su prirodan materijal, pa su negativni uticaji na životnu sredinu tokom proizvodnje i upotrebe ovih vlakana svedeni na minimum.

Tabela 1. Poređenje prosečnih vrednosti karakteristika vlakana [3–6]
Table 1. Comparison of average fiber properties [3–6]

Vlakna <i>Fibres</i>	Zapreminska masa <i>Density</i> (g/cm ³)	Modul elastičnosti <i>Modulus of elasticity</i> (GPa)	Čvrstoća na zatezanje <i>Tensile strength</i> (MPa)
Staklena <i>Glass</i>	2,6	70-80	2000-3500
Karbonska <i>Carbon</i>	1,75-1,95	240-760	2400-5100
Aramidna <i>Aramid</i>	1,45	62-180	3600-3800
Bazaltna <i>Basalt</i>	2,8	90	4800

2.2 Matrica

Matrica je vezivni materijal, sa osnovnim zadatkom da drži vlakna zajedno i sačuva njihovu orijentaciju. Takođe, matrica ima ulogu da štiti vlakna od uticaja okruženja i mehaničkog habanja. Veoma je važno da matrica bude hemijski i termički kompatibilna s vlaknima, kao i da ima malu zapreminsku masu kako ne bi povećavala težinu kompozita [7]. Najčešće korišćeni polimer za FRP materijale u građevinarstvu je epoksid. Poliester ili vinilester se takođe upotrebljavaju. U Tabeli 2 prikazane su osnovne karakteristike matrica.

2.2 Matrix

Matrix is a bonding material, with the main task to hold the fibres together and preserve their orientation. Also, matrix has a role to protect fibres from environmental influences and abrasion. It is very important that the matrix is chemically and thermally compatible with the fibres, and that it has a small density in order to prevent the increase of weight of the composite to the great extent [7]. The most commonly used polymer for FRP materials in construction is epoxy. Polyesters and vinylesters are also used. Table 2 shows the main properties of the matrix.

Tabela 2. Karakteristike matrica [6]
Table 2. Matrix properties [6]

Materijal <i>Material</i>	Zapreminska masa <i>Density</i> (g/cm ³)	Modul elastičnosti <i>Modulus of elasticity</i> (GPa)	Čvrstoća na zatezanje <i>Tensile strength</i> (MPa)
Epoksid <i>Epoxy</i>	1,1-1,4	2,0-6,0	35-130
Poliester <i>Polyester</i>	1,1-1,5	1,2-4,5	40-90
Vinilester <i>Vinylester</i>	1,5	3,0-4,0	65-90

2.3 Kompozit

Karakteristike FRP materijala ne mogu se predvideti jednostavnim sumiranjem karakteristika njegovih sastavnih delova. Vlakna i matrica deluju komplementno da obezbede željene karakteristike obe komponente. Na primer, većina matrica na bazi polimera ima malu čvrstoću na zatezanje, ali izuzetnu tvrdoću i savitljivost, dok tanka vlakna imaju veliku čvrstoću na zatezanje, ali oseljivost na oštećenja. Generalno, karakteristike FRP kompozita zavise od karakteristika materijala vlakana i matrice, orijentacije vlakana (kod šipki obično vlakna postavljena u jednom pravcu), zapreminskog udela vlakana, i tako dalje.

Pultruzija je tehnologija koja se uglavnom koristi za proizvodnju FRP šipki, koje mogu biti u obliku kružnog ili kvadratnog poprečnog preseka, glatke ili

2.3 Composite

The properties of FRP materials cannot be predicted by simple summation of the characteristics of its component parts. The fibres and matrix act complementary so as to provide the desired characteristics of both components. For example, most polymer-based matrices have a low tensile strength, but excellent toughness and flexibility, whereas thin fibres have a high tensile strength, but they are sensitive to damage. Generally, the properties of FRP composites depend on material characteristics of fibre and matrix, fibre orientation (in the case of bars fibres are usually oriented in one direction), the percentage of fibres in the composite, etc.

Pultrusion is a technology that is generally used for production of FRP bars. Bars can have a circular or

rebraste kao i peskarene (slika 1).

square cross section, and they can be smooth or ribbed, as well as sand-coated (Figure 1).



Slika 1. Tipovi FRP šipki
Figure 1. Types of FRP bars

2.4 Lepkovi

Ako nije postignut pravilan spoj između FRP kompozita i drveta neće se ostvariti spregnuto dejstvo i prevremeni lom može se dogoditi pri apliciranju većeg opterećenja. Stoga, uspešna primena FRP kompozita na konstrukcijske elemente zahteva da visokokvalitetni, trajni spoj bude ostvaren između dva različita materijala. Implementacija FRP ojačanja obično zahteva upotrebu lepkova. Postoji nekoliko prednosti primene lepljenog spoja, kao što su: mogućnost povezivanja različitih materijala, obezbeđivanje velike krutosti, ravnomerno raspodeljeno opterećenje i tako dalje. S druge strane, lepkovi su osetljivi na uslove sredine, kao što je vlažnost, i nisu pogodni kada su izloženi visokim temperaturama (otpornost na požar).

Postoji mnogo tipova prirodnih ili sintetičkih lepkova (elastomeri, termoplastični, termostabilni lepkovi) koji se mogu koristiti. Ipak, izbor odgovarajućeg lepka treba da bude načinjen na bazi raspoložive podloge i izabrane vrste FRP šipki. U okviru tehničkih listova za FRP proizvode, proizvođači obično navode koji lepak treba upotrebiti zavisno od konstrukcije koja se ojačava. Najpodesniji lepkovi za kompozitne materijale jesu lepkovi na bazi epoksida. Ovi lepkovi imaju određene prednosti kao što su dobre karakteristike popunjavanja pora na spojnim površinama, ograničeno skupljanje tokom vremena očvršćavanja, sposobnost očvršćavanja na ambijentalnim temperaturama i zahtevanje samo minimalnog pritiska u procesu spajanja.

3 OJAČANJE DRVENIH ELEMENATA IZLOŽENIH SAVIJANJU

Kod drvenih elemenata napregnutih na savijanje, inicijalni lom nastaje uglavnom u zategnutoj zoni u blizini kvrga, defekta ili na mestima poprečnog nastavka lamela kod lepljenih lameliranih nosača. Lom usled zatezanja drveta izloženog savijanju je krt, nasumičan i teško predvidiv. Stoga, drveni nosači se uglavnom ojačavaju na zategnutoj strani, čime se povećava nosivost i krutost na savijanje i postiže znatno duktilniji lom u pritisnutoj zoni. Ojačanje postavljanjem šipki blizu površine u pripremljene proreze ne menja visinu nosača dok istovremeno štiti šipke od spoljašnjih uticaja. U različitim radovima do sada je ispitivano ponašanje monolitnih i lepljenih lameliranih drvenih nosača ojačanih FRP šipkama. U nastavku su prikazana neka od istraživanja.

2.4 Adhesives

If proper connection between FRP and timber is not achieved composite effect is unlikely to be accomplished and premature failure can occur. Therefore, successful application of FRP composites in structural elements requires the achievement of high-quality, durable connection between the two materials. Implementation of FRP reinforcement usually requires use of adhesives. There are several advantages of adhesives, such as the ability to connect different materials, high stiffness, uniformly distributed load, etc. On the other hand, the adhesives are sensitive to environmental factors such as humidity and they are unsuitable when exposed to high temperatures (low fire resistance).

There are many types of natural or synthetic adhesives (elastomers, thermoplastic, thermosetting adhesives) that can be used. However, the suitable adhesive should be chosen based on the material properties of the structure and the type of FRP bars. As part of the technical data sheets for FRP products, manufacturers usually specify which adhesive should be used depending on the structure that is being reinforced. The most suitable adhesives for composite materials are epoxy-based adhesives. These adhesives have certain advantages such as good filling of the pores of bonding surfaces, limited shrinkage during curing, the ability to cure at ambient temperatures and they require only minimal pressure in the process of bonding.

3 STRENGTHENING OF TIMBER ELEMENTS SUBJECTED TO BENDING

In timber elements subjected to bending, initial failure occurs mainly in the tensile zone near knots, defects or finger joints of glued laminated beams. Tensile failure of timber is brittle, random and difficult to predict. Therefore, the timber beams are usually reinforced at tension side, which increases load carrying capacity and flexural stiffness. Also, this type of reinforcement allows for ductile failure in the compressive zone to be achieved. Positioning the bars near the surface in the prepared slots does not change the height of the beam and protects the bars from environmental influences. Various researchers so far have investigated the behaviour of solid and glued laminated timber beams reinforced with FRP bars. Some of the experimental investigations are presented in this paper.

Gentile, Svecova i Rizkalla [8] sprovedli su eksperimentalno ispitivanje s ciljem procene ponašanja na savijanje trideset godina starih drvenih nosača (Duglasova jela) ojačanih šipkama na bazi staklenih vlakana (GFRP). Dvadeset dve grede (10x30x430 cm) isečene iz glavnih nosača starog drvenog mosta, od kojih je 15 ojačanih, ispitano je na savijanje. Grede su bile ojačane GFRP šipkama postavljenim u zategnoj zoni sa bočnih strana (slika 2a). Uticaj površine ojačanja u poprečnom preseku bio je razmatran kroz tri procenta ojačanja: 0,27, 0,41 i 0,82%. Pored gređa, četiri cela glavna nosača mosta (20x60x1040 cm), od kojih su tri ojačana, ispitano je s ciljem utvrđivanja uticaja efekata veličine uzorka na rezultate ojačanja. Ovi nosači su ojačani GFRP šipkama, koje su postavljene u zategnoj zoni s donje strane preseka ili s bočnih strana (slika 2b). Procenti ojačanja kod nosača bili su 0,26 i 0,42%.

Gentile, Svecova and Rizkalla [8] conducted an experimental testing in order to assess flexural behaviour of 30-year-old timber beams (Douglas fir) reinforced with glass fibre reinforced polymer (GFRP) bars. Twenty two beams (10x30x430 cm) cut from the old timber bridge stringers, from which 15 were reinforced, were tested in bending. The beams were reinforced with GFRP bars positioned in tension zone on the sides of the beam (Figure 2a). Reinforcement percentages in the cross section were: 0.27, 0.41 and 0.82%. In addition, four whole timber bridge stringers (20x60x1040 cm), three of which were reinforced, were examined to investigate the size effect on the performance of strengthening technique. These beams were reinforced with GFRP bars, which were positioned in tension zone of the cross-section at the bottom or on the sides (Figure 2b). Percentages of reinforcement for stringers were 0.26 and 0.42%.

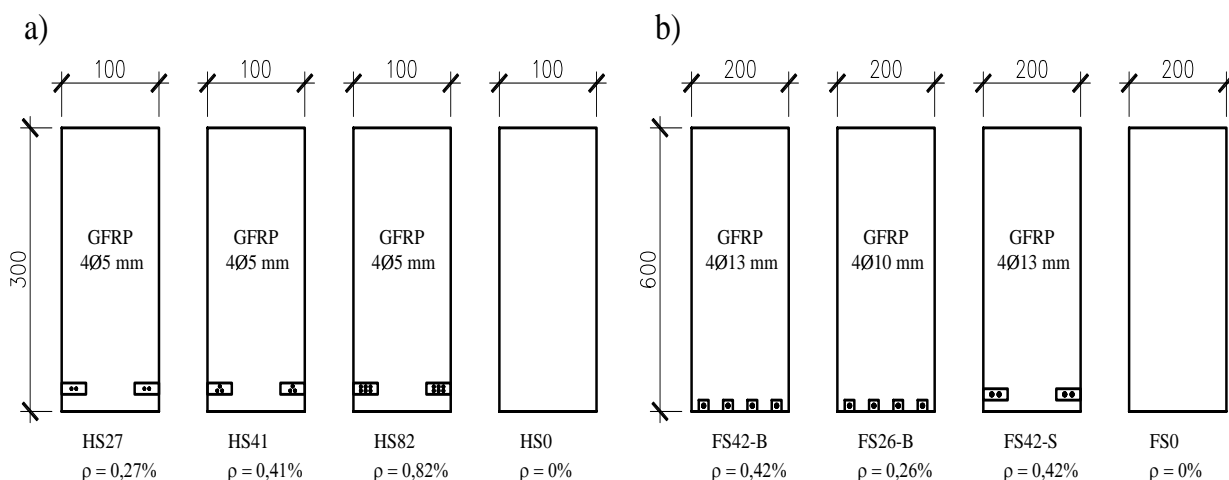

Slika 2. Poprečni preseki ispitanih ojačanih i neojačanih uzoraka [8]
Figure 2. Crosssections of reinforced and unreinforced beams [8]

Istraživanje je pokazalo da su GFRP šipke efikasna tehnika ojačanja na savijanje monolitnih drvenih nosača. Slično ponašanje, u smislu oblika loma, dijagrama opterećenje–ugib, raspodele dilatacija i granične čvrstoće, zabeleženo je kod obe grupe ispitanih uzoraka. Nije evidentiran nikakav efekat veličine uzorka. Za procene ojačanja između 0,27 i 0,82%, granično opterećenje se povećalo 48–60%. Ojačanjem nosača prosečna vrednost granične dilatacije zatezanja drveta povećala se za 64%, što pokazuje da prisustvo ojačanja znatno umanjuje uticaj defekata u drvetu. Osim toga, kod 60% ojačanih uzoraka zabeleženi oblik loma je duktilni lom u pritisnutoj zoni.

Svecova i Eden [9] sprovedli su istraživanje kako bi doprineli razvoju praktične metodologije ojačanja postojećih drvenih mostova primenom GFRP šipki. Povod za ovo istraživanje jeste težnja da se umesto skupe zamene starih i oštećenih drvenih mostova ojačaju postojeće konstrukcije i na taj način im se produži upotrební vek. Eksperimentalni program obuhvatio je ispitivanje na savijanje do loma 45 drvenih gređa (Duglasova jela), isečenih iz glavnih nosača drvenih mostova oblasti Manitoba u Kanadi. Grede su bile dimenzija 10x30x200 cm. Generalno, dve šeme



The research showed that the GFRP bars are effective flexural strengthening technique for solid timber beams. Similar behaviour in terms of failure modes, load-deflection, strain distribution and ultimate strength was observed in both groups of tested beams. Size effect of the beams was not recorded. For reinforcement ratios between 0.27 and 0.82%, ultimate load increased 48-60%. Average tensile strain value increased by 64%, indicating that the presence of reinforcement significantly reduces the influence of defects in timber. In addition, in 60% of reinforced beams ductile failure in the compressive zone was recorded.

Svecova and Eden [9] carried out a research to contribute to the development of reinforcement techniques of existing timber bridges by using GFRP bars. The reason behind this study was the tendency to shift from costly replacements to strengthening of existing structures and thus to extend their service lives. The experimental program included testing in bending of 45 timber beams (Douglas fir), cut from the timber bridge stringers from Manitoba area in Canada. The dimensions of the beams were 10x30x200 cm. Overall, two reinforcement schemes were used in the test program. The first group, Group S, included 16 beams

ojačanja primenjene su u okviru programa ispitivanja. Prva grupa, Grupa S, obuhvatila je 16 greda, koje su ojačane samo vertikalnim šipkama (prečnika 16 mm) kao ojačanjem na smicanje, dok je druga grupa od 20 greda, Grupa SF, pored vertikalnih imala i ojačanja u vidu dve horizontalne šipke sa bočnih strana (prečnika 5 mm), što je predstavljalo kombinaciju ojačanja na savijanje i na smicanje. Položaj i rastojanje vertikalnih šipki, kao i dužina horizontalnih šipki jesu parametri koji su varirani. Rezultati ispitivanja ojačanih greda upoređeni su s rezultatima ispitivanja grupe od devet neojačanih greda (Grupa C). Program eksperimentalnog ispitivanja dat je u tabeli 3.

that were reinforced only with vertical bars (diameter 16 mm) as shear reinforcement. The second group of 20 beams, SF Group, in addition to the vertical reinforcement had two horizontal bars positioned on the sides (diameter 5 mm), which was a combination of flexural and shear reinforcement. The position and spacing of vertical bars, as well as the length of the horizontal bars were the parameters that were varied. The test results of reinforced beams were compared with the results of 9 unreinforced beams (Group C). The program of experimental tests is given in Table 3.

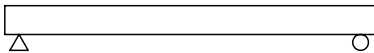
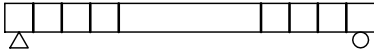
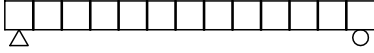
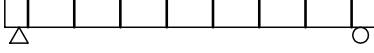
Tabela 3. Program eksperimentalnog ispitivanja [9]
Table 3. The program of experimental tests [9]

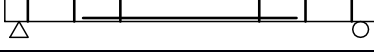
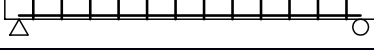
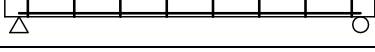
Oznaka uzoraka Beam label	Šema ojačanja Reinforcement scheme	Broj uzoraka Number of beams
C		9
S-S150		5
S-C150		6
S-C300		5
SF-S150		5
SF-S300		5
SF-C150		5
SF-C300		5

Eksperimentalno ispitivanje dovelo je do sledećih zaključaka:

- upotreba GFRP šipki pokazala se kao primenljiva za ojačanje drvenih greda;
- optimalno rastojanje vertikalno postavljenih šipki za povećanje smičuće nosivosti treba da bude jednako širini poprečnog preseka;
- grede ojačane samo na smicanje pokazale su povećanje nosivosti od 33%, dok su kombinovano ojačane grede pokazale povećanje od 47% do 52%;
- upotreba kombinovanog ojačanja uzrokuje lom u pritisnutoj zoni, kome prethode velike deformacije, što može poslužiti kao upozorenje pre loma grede;
- upotreba ojačanja smanjuje prirodnu varijabilnost mehaničkih karakteristika drveta u različitim pravcima;
- veze između GFRP, lepka i drveta nisu pokazale znake popuštanja pre nastupanja loma čitave grede;
- dijagrami kombinovano ojačanih greda opterećenje–ugib pokazali su duktilno ponašanje, pri čemu je 60% greda imalo dva puta veće ugibe pri lomu u odnosu na neojačane grede.

Istraživanje Amy i Svecova [10] predstavlja nastavak eksperimentalnog programa ojačanja glavnih nosača

The research has led to the following conclusions:

- Use of GFRP bars proved to be feasible for reinforcing timber beams;
- Optimal spacing between vertical shear bars is equal to the width of the cross section;
- Shear reinforced beams have shown an increase in load carrying capacity of 33%, while both shear and flexural reinforced beams showed an increase of 47% to 52%;
- Using both flexural and shear strengthening of timber increased the strength of the beams and also introduced compressive failure accompanied by large deflections before it, which served as warning of impending failure;
- Introduction of both flexural and shear reinforcement reduced the inherent strength variability of timber;
- Bonds between GFRP, timber and epoxy showed no signs of fracture before the failure of the entire beam;
- Load–deflection curves of beams from group SF became pseudo-ductile with 60% of tested beams experiencing twice the amount of deflection compared with control beams.

drvenih mostova. Sva istraživanja do tada su sprovedena na pravougaonim gredama bez zasečenih krajeva. Međutim, većina drvenih nosača u okviru mostova u kanadskoj oblasti Manitoba imala je redukovanu visinu na krajevima. Zbog koncentracije napona na mestu nagle promene visine, na zasečenim delovima nosača, ovaj eksperimentalni program obuhvatio je ojačanje zasečenih drvenih nosača. Ukupno 26 drvenih nosača (10x40x340 cm) ispitano je na savijanje do loma: osam neojačanih (kontrolnih) uzoraka (Grupa C), 12 ojačanih horizontalnim GFRP šipkama (prečnika 12 mm) u oblasti najvećih napona savijanju u zategnutoj zoni (Grupa F) i šest ojačanih horizontalnim GFRP šipkama u zategnutoj zoni i kosim GFRP šipkama, pod uglom od 60° prema horizontalnoj ravni, kao ojačanje na smicanje (Grupa FD). Program eksperimentalnog ispitivanja dat je u tabeli 4.

The research of Amy and Svecova [10] represents further investigation of timber bridge stringers reinforcement. All previous research in this area was conducted on rectangular beams, without dapped ends. However, the majority of timber bridge stringers in Manitoba (Canada) have dapped ends. Because of the stress concentration at daps, this experimental program investigated flexural strengthening of dapped timber stringers. A total of 26 timber beams (10x40x340 cm) were tested in bending to failure: 8 unreinforced (control) stringers (group A), 12 stringers reinforced with GFRP bars (diameter 12 mm) in tensile region (Group F) and 6 stringers reinforced with GFRP bars in tensile zone and GFRP dowel bars inclined at an angle of 60° to the horizontal plane for shear reinforcement (Group FD). The program of experimental tests is given in Table 4.

Tabela 4. Program eksperimentalnog ispitivanja [10]
Table 4. The program of experimental tests [10]

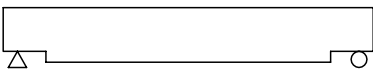
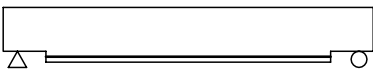
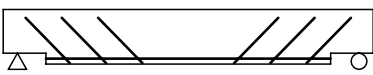
Grupa uzoraka <i>Beam group</i>	Šema ojačanja <i>Reinforcement scheme</i>	Broj uzoraka <i>Number of beams</i>
C		8
F		12
FD		6

Primena samo ojačanja na savijanje ne preporučuje se za zasečene nosače, jer je dominantan smičući lom na zasečenom delu, koji znatno redukuje nosivost nosača. Usled primene ojačanja i na savijanje i na smicanje za ovaj tip nosača povećalo se granično opterećenje za 22%, uz promenu oblika loma (pritisak upravno na vlakna u pritisnutoj zoni). Duktilnost nosača je, takođe, povećana primenom GFRP ojačanja. Znatno veće povećanje duktilnosti zabeleženo je kod nosača ojačanih i na savijanje i na smicanje u odnosu na nosače ojačane samo na savijanje.

Borri, Corradi i Grazini [11] su teorijski i eksperimentalno ispitivali ojačanja postojećih drvenih elemenata izloženih savijanju primenom FRP materijala. Kako bi utvrdili krutosti, nosivosti i duktilnosti ojačanih drvenih greda, dvadeset greda dimenzija 20x20x400 cm ispitano je u okviru eksperimentalnog dela. Pored uzoraka ojačanih karbonskim tkaninama, ispitano je i pet drvenih greda ojačanih karbonskim šipkama (CFRP). U zategnutoj zoni, blisko donjoj površini, postavljena je jedna ili dve šipke, prečnika 7,5 mm (slika 3). Dodatno, jedna greda je ojačana s dve prednapregnute karbonske šipke.

The use of flexural reinforcement only is not recommended for dapped beams because shear failures at daps can occur and reduce the ultimate strength of the beam significantly. The use of both flexural and shear reinforcement for this type of beams has led to an increase in ultimate load of 22%, with a change of failure mode (compression perpendicular to the grain in the compressive zone). Ductility of stringers was also improved by GFRP reinforcement. Beams with both flexural and shear reinforcement had significantly greater ductility increase compared to those with only flexural reinforcement.

Borri, Corradi and Grazini [11] have theoretically and experimentally investigated the strengthening of existing timber elements subjected to bending with FRP materials. In order to determine the stiffness, load carrying capacity and ductility of reinforced timber beams, 20 beams (20x20x400 cm) were experimentally tested. In addition to the beams reinforced with carbon fibre reinforced polymer (CFRP) sheets, 5 timber beams reinforced with CFRP bars were tested. In tensile zone, close to the bottom surface, one or two bars with a diameter of 7.5 mm were placed (Figure 3). In addition, one beam was reinforced with two prestressed carbon bars.

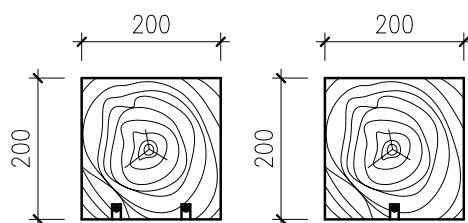

Slika 3. Šeme ojačanja greda s karbonskim šipkama [11]
Figure 3. Schemes for beams with CFRP bar reinforcement [11]

U oba slučaja ojačanja s karbonskim šipkama zabeleženo je povećanje nosivosti i krutosti (28,9% i 22,0% za slučaj jedne šipke, odnosno 52,0% i 25,5% za slučaj dve šipke). Međutim, grede ojačane karbonskim šipkama pokazale su manje duktilno ponašanje od greda ojačanih karbonskim tkaninama, kao i u poređenju s neojačanim gredama. Pozitivan efekat izazvan prisustvom šipki nije bio dovoljan da ograniči lokalna oštećenja i premosti lokalne defekte u drvetu. Prednaprezanje CFRP šipki nije vodilo ka bilo kakvom značajnijem poboljšanju u poređenju s neprednapregnutim ojačanjem. Kako se radilo o malom broju uzoraka, autori preporučuju dalja eksperimentalna ispitivanja s različitim vrstama drveta i većim brojem greda.

Micelli, Scialpi i La Tegola [12] razmatrali su mogućnost upotrebe šipki na bazi karbonskih vlakana (CFRP) kao ojačanja lepljenih lameliranih drvenih nosača. Šest nosača od lepljenog lameliranog drveta (smreka), od čega četiri ojačana, ispitano je na savijanje. Nosači (12x20x500 cm) su ojačani karbonskim šipkama prečnika 12,5 mm (jednom ili dve) postavljenim u zategnutoj zoni, u neposrednoj blizini donje površine (slika 4).

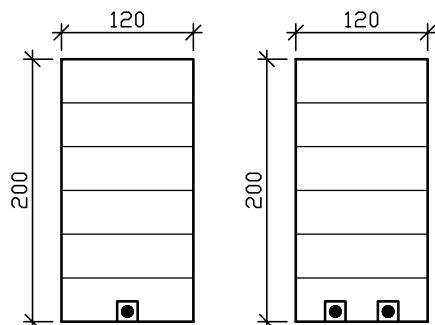

Slika 4. Poprečni preseki ojačanih nosača [12]
Figure 4. Crosssections of reinforced beams [12]

Eksperimentalni rezultati su pokazali da se postavljanjem CFRP šipki sa zategnute strane poprečnog preseka može značajno poboljšati nosivost i krutost nosača. Za procenete ojačanja 0,51% i 1,03%, zabeleženo je povećanje graničnog momenta od 26% i 82%, odnosno povećanje krutosti od 8% i 19% u odnosu na neojačane nosače. Oblici loma i eksperimentalni podaci pokazali su odlične karakteristike spoja između drveta i karbonskih šipki. Lom kako neojačanih, tako i ojačanih nosača zavasio je pre svega od čvrstoće drveta na zatezanje.

Johnsson, Blanksvard i Carolin [13] su istraživali ojačanje nosača od lepljenog lameliranog drveta

In both cases of the beams reinforced with CFRP bars an increase in maximum load and stiffness was recorded (28.9% and 22.0% in the case of one bar, and 52.0%, and 25.5% in the case of two bars). However, the beams reinforced with CFRP bars have shown less ductile behaviour when compared to the beams reinforced with CFRP sheets, as well as compared to unreinforced beams. The positive effect caused by the presence of bars was insufficient to limit raptures and bridge local defects in timber. Prestressing CFRP bars did not lead to any significant improvement compared to regular reinforcement. Since the number of specimens was small, the authors recommended further research with different types of wood and a larger number of beams.

Micelli, Scialpi and La Tegola [12] investigated the possibility of using CFRP bars as a reinforcement for glued laminated timber beams. Six glued laminated timber (spruce) beams, out of which four were reinforced, were tested in bending. Specimens (12x20x500 cm) were reinforced with CFRP bars with a diameter of 12.5 mm (one or two bars) in the tensile zone, close to the bottom surface (Figure 4).





Experimental results showed that CFRP bars positioned in tensile zone can significantly improve ultimate moment and stiffness of the beam. For reinforcement ratios of 0.51% and 1.03%, an increase in the ultimate moment was recorded 26% and 82%, and an increase in stiffness 8% and 19% compared to unreinforced beams. Failure modes and experimental data showed excellent bond properties between timber and bars. Failure of both unreinforced and reinforced beams depended primarily on the tensile strength of timber.

Johnsson, Blanksvard and Carolin [13] explored

pomoću CFRP šipki. Posebna pažnja bila je usmerena ka utvrđivanju potrebne minimalne dužine sidrenja ojačanja, pri kojoj neće doći do pojave prevremenog loma. Ukupno je ispitano deset lepljenih lameliranih nosača (smreka), porečnog preseka 9x22,5 cm i dužine 350 cm. Karbonske šipke (pravougaonog poprečnog preseka, 10x10 mm) postavljene su unutar preseka, u neposrednoj blizini donje površine. Program eksperimentalnog ispitivanja dat je u tabeli 5.

reinforcing glued laminated timber beams using CFRP bars. Special attention was given to the minimum anchoring length of reinforcement that will not cause premature failure. A total of 10 glulam beams (spruce) were tested (9 x 22.5 x 350 cm). CFRP bars (rectangular, 10 x 10 mm) were placed inside the cross section near the bottom surface. The program of experimental tests is given in Table 5.

Tabela 5. Program eksperimentalnog ispitivanja [13]
Table 5. The program of experimental tests [13]

Seriya uzoraka <i>Beam series</i>	Tip <i>Type</i>	Ojačanje <i>Reinforcement</i>	Broj uzoraka <i>Number of beams</i>
1		Bez ojačanja <i>No reinforcement</i>	3
2		1 šipka centralno postavljena u zategnutoj zoni, celom dužinom nosača <i>1 bar centrally positioned in tensile zone, along the beam's length</i>	3
3		2 šipke simetrično postavljene u zategnutoj zoni, celom dužinom nosača <i>2 bars symmetrically positioned in tensile zone, along the beam's length</i>	3
4		1 šipka centralno postavljena u zategnutoj zoni, kraće dužine <i>1 bar centrally positioned in tensile zone, shorter length</i>	1

Rezultati su pokazali da pored povećanja nosivosti na savijanje od 40 do 60% i povećanja krutosti od 5 do 25% ovaj metod ojačanja menja tip loma iz krkog u zatežućoj zoni u duktilni lom u pritisnutoj zoni. Kao posledica duktilnog ponašanja ojačanih nosača, ugib u sredini nosača pri lomu povećao se do 80%. Rezultati eksperimentalne i teorijske analize dužine sidrenja CFRP šipke pokazali su da je minimalna potrebna dužina 150 mm.

Raftery i Whelan [14] su u svom radu istraživali različite dispozicije ojačanja lepljenog lameliranog drveta niže klase sa GFRP šipkama (slika 5). Ispitano je pet nosača svake serije s rasponom od 342 cm i dimenzijama poprečnog preseka 9,6x19 cm. Kao što se može videti na slici 5, ispitivan je uticaj upotrebe više šipki manjeg prečnika naspram šipki većeg prečnika, zatim oblik proreza u koji se postavljaju šipke, kao i ojačanje u obe zone (pritisnuta i zategnuta zona) nosača. Procenti ojačanja za razmatrane šeme ojačanja iznosili su redom: 1,05; 1,4; 1,4 i 2,8%.

Zaključci dobijeni eksperimentalnim ispitivanjem su sledeći:

- veći kapacitet nosivosti i veća krutost dostižu se primenom kružnih u odnosu na kvadratne proreze za postavljanje šipki usled smanjenja koncentracije napona na ivicama proreza;
- upotreba više šipki manjih prečnika nije pokazala poboljšanje u nosivosti i krutosti bez obzira na povećanje površine lepljenja između lepka i šipki;

The results showed that in addition to flexural capacity increase of 40-60% and an increase in stiffness of 5-25% this method changes the type of failure from brittle in tensile zone to ductile failure in compressive zone. As a result of ductile behaviour of the reinforced beams, the mid-span deflection at failure increased up to 80%. The results of experimental and theoretical analysis of the anchoring length of CFRP bars showed that the minimum required length was 150 mm.

Raftery and Whelan [14] explored different arrangements of reinforcing low-grade glulam beams using GFRP bars (Figure 5). Five beams of each series with a span of 342 cm and cross section dimensions of 9.6x19 cm were tested. As it can be seen in Figure 5, they inspected the use of multiple bars with smaller diameter against the bars with larger diameter, shape of the grooves where bars were placed and reinforcement in both compressive and tensile zone of the beam. The reinforcement ratios for different schemes were, respectively: 1.05; 1.4; 1.4 and 2.8%.

The conclusions obtained by experimental tests were as follows:

- Greater ultimate moment capacity and stiffness were achieved with the use of circular routed out grooves in comparison with square grooves for the reinforcement, due to the reduction of stress concentration at the edges of the groove;
- The use of multiple smaller diameter bars per groove showed no improvement in strength and stiffness regardless to the increase of the bond surface area between adhesive and bars;

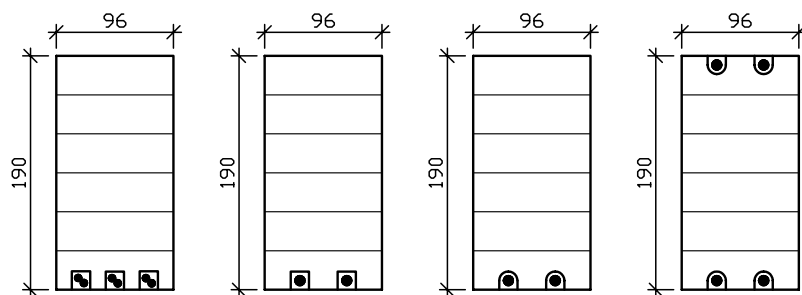

Slika 5. Poprečni preseki ojačanih nosača [14]
Figure 5. Cross sections of reinforced beams[14]

– ojačani nosači dostigli su duktilni lom u pritisnutoj zoni za razliku od neojačanih koji su krtili lom dostizali u zategnutoj;

– s većim procentom ojačanja postiže se i veće iskorišćenje mehaničkih svojstava drveta u pritisnutoj zoni;

– upotreba procenta ojačanja od 1,4% u zategnutoj zoni dovela je do povećanja krutosti od 11,2% i nosivosti od 68%, dok je ojačanje od 1,4% u zategnutoj i 1,4% u pritisnutoj zoni dovelo do povećanja krutosti od 22% i nosivosti od 98,5%.

Raftery i Kelly [3] su istraživali primenu šipki na bazi bazaltnih vlakana (BFRP). U svom radu su pokazali da BFRP šipke imaju nešto bolje karakteristike od GFRP šipki. Ispitano je pet nosača svake serije sa rasponom od 342 cm i dimenzijama poprečnog preseka 9,6x19 cm. Rezultati ojačanja su dosta slični onim koji se dobijaju ojačavanjem GFRP šipkama. Pored postavljanja ojačanja na donjoj zategnutoj strani nosača, ispitano je i postavljanje šipki u proreze sa strane (slika 6), što je povoljnije sa estetske strane. Međutim, ovako postavljeno ojačanje daje manje povećanje nosivosti nosača, jer položaj ojačanja nije optimalan u odnosu na neutralnu osu poprečnog preseka.

– Reinforced beams have reached the ductile failure in the compressive zone in comparison with the unreinforced beams that reached brittle tensile failure;

– With higher reinforcement percentages greater utilisation of mechanical properties of timber in the compressive zone was achieved;

– The use of reinforcement percentage of 1.4% in the tensile zone has led to an increase in stiffness of 11.2% and ultimate moment capacity of 68%, while the reinforcement of 1.4% in the tensile and 1.4% in the compressive zone has led to an increase in stiffness of 22% and ultimate moment capacity of 98.5%.

Raftery and Kelly [3] investigated the use of basalt fibre reinforced polymer (BFRP) bars. In this paper it was shown that BFRP bars have a somewhat better performance than the GFRP bars. Five beams of each series with a span of 342 cm and the cross section dimensions 9.6x19 cm were tested. The results of reinforcement are quite similar to those obtained from reinforcing with GFRP bars. In addition to positioning the reinforcement on the bottom tensile side of the beams, positioning the bars into slots on the sides was also investigated (Figure 6), which is aesthetically more favourable. However, this provided a lesser increase in the ultimate moment capacity, because the position of the bars was not optimal in relation to the neutral axis of the cross section.

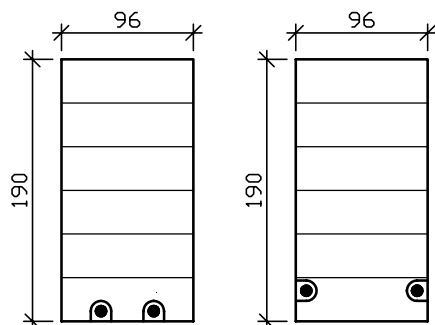

Slika 6. Poprečni preseki ojačanih nosača [3]
Figure 6. Cross sections of reinforced beams [3]

Lokalno ojačanje drvenih nosača različitim vrstama FRP šipki prikazali su Franke, Franke i Harte [15]. U slučaju kada se oslanjanje nosača izvodi s redukovanom visinom nosača iznad oslonca, koncentracije napona koje se javljaju u uglu uzrokuju otvaranje pukotina na

Local reinforcement of timber beams using FRP bars was investigated by Franke, Franke and Harte [15]. In the case of notched end beams, the stress concentration at the corner of the notch leads to crack initiation and rapid crack propagation, which can result in a sudden

tom mestu i njihovu brzu progresiju kroz poprečni presek elementa, što može izazvati lom. Pored smičućih napona javljaju se i naponi zatezanja upravni na vlakna. Predložene metode ojačanja prikazane su na slici 7 [15]. Ojačanje je postavljeno upravno na vlakna ili pod uglom od 45°.

brittle failure of the beam. In addition to shear stress, high tensile stress perpendicular to the grain occurs. The proposed reinforcement methods are shown in Figure 7 [15]. Reinforcement was positioned perpendicular to the grain or at an angle of 45° to the beam axis.

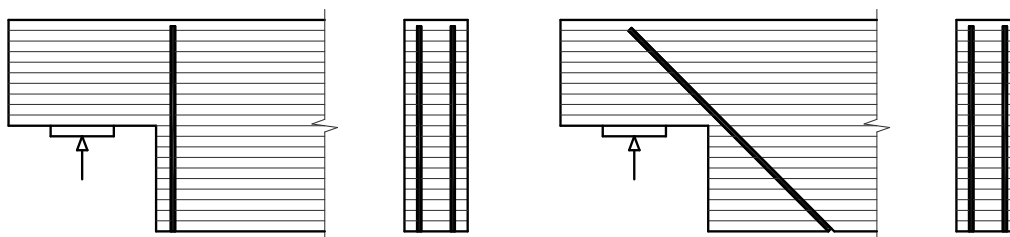

Slika 7. Ojačanje na mestu redukovane visine nosača – neposredno uz oslonac [15]
Figure 7. Reinforcement arrangements for notches [15]

Primena ojačanja pod uglom od 45° dala je znatno bolje rezultate, pre svega zbog velikih smičućih napona u ovim preseccima. Pored povećanja nosivosti, ojačanje ovog tipa omogućilo je i duktilniji lom nosača. Istraživanje je pokazalo da FRP šipke treba da budu postavljene što bliže uglu zasecanja, pri čemu je veoma važno da uslov o minimalnim rastojanjima bude zadovoljen.

The use of reinforcement at an angle of 45° showed significantly better results, primarily due to high shear stresses. In addition to enhanced load carrying capacity, the reinforcement allowed for less brittle failure modes of the beams to occur. Research has shown that FRP bars should be placed as close as possible to the notch corner, while also satisfying the requirements for minimum edge distance and spacing of the bars.

Yang i grupa autora [16] su istraživali ojačanje lepljenolameliranih nosača sa GFRP šipkama, GFRP i CFRP trakama i čeličnim šipkama. Nosači dimenzija poprečnog preseka 7,5x30 cm ispitivani su na savijanje. Ukupno 46 nosača dužine 6 m i raspona 5,7 m eksperimentalno je testirano. Konfiguracija ojačanja šipkama prikazana je na slici 8. Dobijeni rezultati su upoređeni sa analitički određenim vrednostima.

Yang et al.[16] investigated reinforcement of glulam beams with GFRP bars, GFRP and CFRP plates and steel bars. Beams with cross section dimensions of 7.5x30 cm were tested in bending. Total of 46 beams with a length of 6 m and 5.7 m span were experimentally tested. Configuration of the reinforcement bars is shown in Figure 8. The results were compared with analytically obtained values.

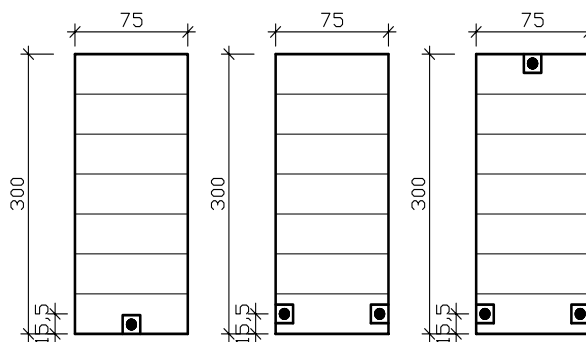

Slika 8. Šeme ojačanja greda s karbonskim šipkama [16]
Figure 8. Schemes for beams with CFRP bar reinforcement [16]

Eksperimenti su pokazali da s povećanjem procenta ojačanja raste nosivost, krutost, maksimalni ugib u sredini nosača, kao i duktilnost nosača. Postavljanje ojačanja i u pritisnutoj zoni umanjuje duktilnost i nelinearno ponašanje u poređenju s gredama ojačanim samo u zategnutoj zoni. Takođe, ojačanje u pritisnutoj zoni dovodi do vrlo malog povećanja kapaciteta nosivosti u odnosu na iste nosače ojačane samo u zategnutom delu preseka.

Experiments have shown that with the increase in reinforcement percentages ultimate load, stiffness, maximum mid-span deflection, and ductility of the beam increases. Introduction of compressive reinforcement reduced ductility and nonlinear behaviour in comparison with the beams reinforced only in the tensile zone. Also, compressive reinforcement led to a very small increase in the load carrying capacity compared to the same beam reinforced only in the tensile zone.

4 ANALITIČKI PRORAČUN

4.1 Proračunski model

Razvoj proračunskog modela kojim se može odrediti krutost i granična nosivost ojačanih nosača važan je za optimalnu upotrebu FRP šipki, kao i za njihovu širu primenu. Proračun drvenih konstrukcija obično se sprovodi prema teoriji dopuštenih napona usled anizotropnog i složenog ponašanja drveta kao materijala. Kod drvenih nosača izloženih savijanju inicijalni lom nastaje uglavnom u zategnutoj zoni, a ponašanje drveta se predstavlja jednostavnim linearno-elastičnim modelom. Dodavanjem kompozitnih materijala drvenim elementima, veza napon-dilatacija u poprečnom preseku se menja, pa pri proračunu treba uzeti u obzir i plastično ponašanje drveta u pritisnutoj zoni. Kako bi se što bolje prikazalo ponašanje ojačanih drvenih nosača, nelinearnost mora biti izražena u analitičkom modelu.

Na osnovu dosadašnjih ispitivanja [16] prikazan je teorijski model s ciljem predviđanja ponašanja drvenih nosača ojačanih FRP šipkama. Analitičkim proračunom se određuje moment savijanja u najopterećenijem preseku nosača za određeni nivo dilatacije zatezanja ivičnih drvenih vlakana.

Osnovne pretpostavke modela su:

- poprečni presezi pri deformaciji ostaju ravni;
- lepljeni sloj između šipke i drveta je idealan;
- ponašanje drveta je linearno-elastično pri zatezanju i elasto-idealno plastično pri pritisku;
- ponašanje FRP ojačanja pri zatezanju je linearno-elastično;
- uticaj slabljenja poprečnog preseka usled plastifikacije se zanemaruje.

Ojačani drveni nosač se ponaša linearno-elastično do dostizanja dilatacije tečenja drveta na gornjoj ivici preseka. Kada dilatacija pritiska pređe granicu elastičnosti javlja se plastifikacija pritisnute zone i pomera se neutralna osa. Ponašanje nosača nakon toga je plastično do loma, dostizanjem graničnog napona zatezanja na donjoj ivici ili loma usled dostizanja granične dilatacije pritiska na gornjoj ivici drvenog preseka.

Idealizovana raspodela dilatacija i napona po visini ojačanog nosača poprečnog preseka ojačanog FRP šipkama ukupne površine poprečnog b/h preseka A_f prikazana je na slici 9.

Ako su dilatacije ε_{wt} i ε_{wcy} poznate (eksperimentalno utvrđene ili standardom definisane) iz uslova kompatibilnosti mogu se odrediti karakteristične dilatacije u poprečnom preseku:

$$\varepsilon_{wc} = (z_3 + z_2) / z_2 \cdot \varepsilon_{wcy}$$

$$\varepsilon_f = (z_1 - a) / z_1 \cdot \varepsilon_{wt}$$

sa

with

$$z_2 = \varepsilon_{wcy} / \varepsilon_{wt} \cdot z_1$$

$$z_3 = h - (z_1 + z_2)$$

4 THEORETICAL ANALYSIS

4.1 Proposed model

Development of theoretical model that can determine the stiffness and ultimate moment capacity of reinforced beams is important for optimal use of FRP bars, as well as their wider application. Design of timber structures is usually performed according to allowable stress design due to anisotropic and complex behaviour of timber as a material. For timber beams exposed to bending initial failure occurs mainly in tensile zone and timber behaviour is presented by simple linear-elastic model. By adding a composite material to timber element stress-strain relationship in cross section changes, therefore the design should take into account plastic behaviour of timber in the compressive zone. In order to accurately describe the behaviour of reinforced timber beams, nonlinearity must be considered in the analytical model.

Based on previous research [16] a theoretical model was developed in order to predict the behaviour of timber beams reinforced with FRP bars. Analytical design determines ultimate moment capacity of the beam for a known ultimate tensile strain of edge timber fibres.

Basic assumptions of the model are:

- The cross sections under deformation remain plane;
- Bond layer between bars and timber is ideal;
- he behaviour of timber is linear-elastic in tension and elastic-perfectly plastic in compression;
- Behaviour of FRP reinforcement in tension is linear elastic;
- The weakening of the cross section due to plasticization is not taken into account.

Reinforced timber beam acts linear elastic until it achieves yielding of timber at the top of the beam. When the compressive strain exceeds ultimate elastic strain plasticization of compressive zone occurs and there is a shift of neutral axis. Behaviour of the beam after that is plastic until it reaches the tensile failure at the bottom or failure caused by the ultimate compressive strain at the top of the cross section.

Idealised stress and strain distribution through the height of the beam (dimensions b/h) reinforced with FRP bars with cross section of A_f is shown in Figure 9.

For known strains ε_{wt} and ε_{wcy} (experimentally obtained or defined in the standard) characteristic strains can be determined from compatibility conditions:

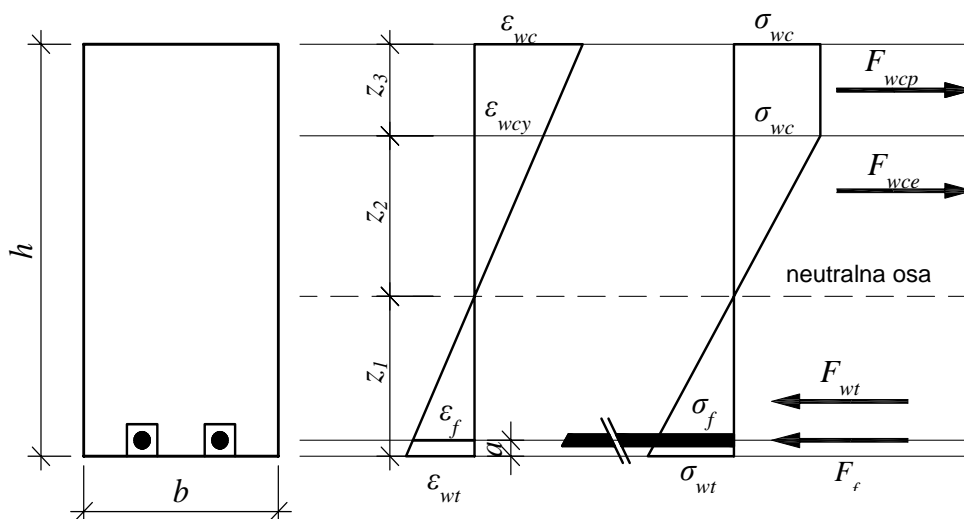

Slika 9. Raspodela napona i dilatacija u okviru poprečnog preseka
Figure 9. Stress and strain distribution in the cross section

gde je:

ε_{wt} – dilatacija zatezanja na donjoj ivici drvenog preseka;

ε_{wcy} – dilatacija plastičnog tečenja drveta;

ε_{wc} – dilatacija pritiska na gornjoj ivici drvenog preseka;

ε_f – dilatacija zatezanja u FRP šipkama;

z_1 – rastojanje neutralne ose do donje ivice drvenog preseka;

z_2 – rastojanje neutralne ose do zone plastifikacije drvenog preseka;

z_3 – visina zone plastifikacije drvenog preseka;

a – rastojanje od donje ivice drvenog preseka do težišta FRP šipki;

Za poznate dilatacije, vrednosti napona se mogu izračunati prema poznatim vezama napon–dilatacija:

$$\sigma_{wt} = E_w \cdot \varepsilon_{wt}$$

$$\sigma_{wc} = E_w \cdot \varepsilon_{wcy} = f_{wc}$$

$$\sigma_f = E_f \cdot \varepsilon_f$$

gde je:

σ_{wt} – napon zatezanja na donjoj ivici drvenog preseka;

σ_{wc} – napon pritiska u okviru zone plastifikacije drvenog preseka;

σ_f – napon zatezanja u FRP šipkama;

E_w – modul elastičnosti drveta pri savijanju;

E_f – modul elastičnosti FRP šipke;

f_{wc} – čvrstoća drveta na pritisak;

where:

ε_{wt} – tensile strain of timber at the bottom;

ε_{wcy} – compressive yield strain of timber;

ε_{wc} – compressive strain of timber at the top;

ε_f – tensile strain of FRP bars;

z_1 – distance of neutral axis from bottom of the cross section;

z_2 – distance of neutral axis from plasticized zone of timber;

z_3 – height of plasticized zone of timber;

a – distance from the bottom of cross section to the centroid of FRP bars;

For known strains, stress values can be calculated through known stress-strain relationships:

where:

σ_{wt} – tensile stress in timber at the bottom;

σ_{wc} – compressive yield stress in timber;

σ_f – tensile stress in FRP bars;

E_w – timber modulus of elasticity in bending;

E_f – FRP bars modulus of elasticity;

f_{wc} – compressive strength of timber;

Položaj neutralne ose određuje se iz uslova ravnoteže unutrašnjih sila:

The position of neutral axis is determined from internal forces equilibrium equations:

$$F_{wcp} + F_{wce} = F_f + F_{wt}$$

gde su unutrašnje sile definisane u skladu s dijagramima napona u poprečnom preseku:

where internal forces are defined in accordance to the stress configuration in the cross section:

$$\begin{aligned} F_{wcp} &= z_3 \cdot b \cdot \sigma_{wc} \\ F_{wce} &= 0,5 \cdot z_2 \cdot b \cdot \sigma_{wc} \\ F_{wt} &= 0,5 \cdot z_1 \cdot b \cdot \sigma_{wt} \\ F_f &= A_f \cdot \sigma_f \end{aligned}$$

Rezultujući moment savijanja može se izračunati kao suma momenata unutrašnjih sila oko neutralne ose:

Ultimate moment can be calculated as a sum of moments from internal forces around neutral axis:

$$M_u = \frac{2}{3} \cdot z_1 \cdot F_{wt} + (z_1 - a) \cdot F_f + \left(z_2 + \frac{z_3}{2} \right) \cdot F_{wcp} + \frac{2}{3} \cdot z_2 \cdot F_{wce}$$

Krutost na savijanje ojačanih nosača može se izračunati koristeći teoriju kruto spregnutih preseka za linearno-elastično stanje. Plastične deformacije ne razmatraju se jer se krutost koristi za proveru graničnog stanja upotrebljivosti. Položaj neutralne ose u odnosu na težište drvenog preseka, odnosno ojačanja z_w i z_f (slika 10) računaju se prema izrazima:

Flexural stiffness of reinforced beams can be calculated using the theory of composite cross sections in the linear-elastic state. Plastic deformations are not considered because the stiffness is used for serviceability limit states. The position of the neutral axis with respect to the centroid of timber cross section and reinforcement, z_w and z_f (Figure 10) is calculated as follows:

$$\begin{aligned} z_w &= \frac{E_f \cdot A_f \cdot \left(\frac{h}{2} - a \right)}{E_w \cdot A_w + E_f \cdot A_f} \\ z_f &= \frac{h}{2} - a - z_w \end{aligned}$$

Krutost na savijanje može se izračunati prema sledećem izrazu:

Flexural stiffness is calculated as follows:

$$EI = E_w \cdot I_w + E_f \cdot I_f + E_w \cdot A_w \cdot z_w^2 + E_f \cdot A_f \cdot z_f^2$$

gde su A_w i A_f površine poprečnih preseka drveta i ojačanja, a I_w i I_f su sopstveni momenti inercije poprečnog preseka drveta i ojačanja.

where A_w and A_f are areas of cross section of timber and reinforcement, and I_w and I_f are moments of inertia of timber and reinforcement.

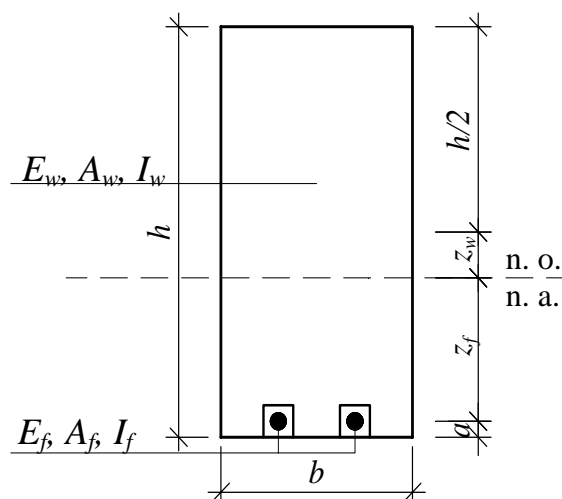

Slika 10. Geometrijske karakteristike poprečnog preseka potrebne za proračun krutosti
 Figure 10. Geometry properties of the cross section necessary for stiffness calculation

4.2 Verifikacija proračunskog modela

Verifikacija predloženog analitičkog modela izvršena je poređenjem sa eksperimentalno dobijenim rezultatima iz istraživanja sprovedenog u [16]. Da bi se usvojeni model primenio, potrebno je poznavati vrednosti napona i dilatacija koje definišu konstitutivne modele materijala. Zato je izbor adekvatnih vrednosti za granične napone drveta najbitnija tačka proračuna. Mehaničke karakteristike za drvo i GFRP šipke korišćene u proračunu date su u tabeli 6.

4.2 Verification of theoretical model

Verification of proposed analytical model was done through comparison with experimental results obtained from a research carried out in [16]. In order to implement the model it is necessary to know the values of stresses and strains that define the constitutive models of materials. Thus, the selection of appropriate values of ultimate timber stresses is the most important step of the calculation. The mechanical properties of timber and GFRP bars used in the calculation are given in Table 6.

Tabela 6. Mehaničke karakteristike materijala [16]
 Table 6. Mechanical properties of materials [16]

Karakteristika Property	Vrednost Value
ε_{wtu} Granična dilatacija zatezanja pri savijanju drveta Ultimate tensile strain of timber in bending	3,56‰
ε_{wcy} Dilatacija plastičnog tečenja drveta Compressive yield strain of timber	3,35‰
ε_{wcu} Granična dilatacija pritiska drveta Ultimate compressive strain of timber	12‰
f_{wc} Čvrstoća drveta na pritisak Compressive strength of timber	36 MPa
E_w Modul elastičnosti drveta pri savijanju Timber modulus of elasticity in bending	10760 MPa
E_f Modul elastičnosti GFRP šipke Ø12 Ø12 GFRP bar modulus of elasticity	35300 MPa
E_f Modul elastičnosti GFRP šipke Ø16 Ø16 GFRP bar modulus of elasticity	30400 MPa

Prilikom modeliranja drveta kao materijala uzeta je u obzir činjenica da je granični napon zatezanja pri lomu usled savijanja veći nego pri lomu usled aksijalnog zatezanja. Takođe, granični napon zatezanja može biti efikasno povećan primenom FRP ojačanja. Veći naponi pri lomu ukazuju na veće dilatacije pri lomu. Shodno rezultatima merenih dilatacija, usvojeno je povećanje granične dilatacije zatezanja, date u tabeli 6 za 30% usled prisustva GFRP šipki [16].

The fact that tensile stress at failure in bending is higher than tensile stress at failure in tension should be taken into account in timber material modelling. In addition, ultimate tensile stress can be effectively increased by addition of FRP reinforcement. Higher stress at failure points to higher strain at failure. Based on the results of measured strains, a 30% increase in the ultimate tensile strain given in Table 6 is adopted due to the presence of the GFRP bars [16].

U tabeli 7 prikazane su vrednosti eksperimentalnih rezultata za granični moment i krutost na savijanje i vrednosti ovih veličina prema analitičkom proračunu. Analiza je uključila grede s procentima ojačanja 0,5% (serija GR0.5), 1% (serija GR1.0) i 1,8% (serija GR1.8) ojačanja.

Table 7 shows experimental and analytical values for ultimate moment and flexural stiffness. The analysis included beams with reinforcement percentages of 0.5% (series GR0.5), 1% (series GR1.0) and 1.8% (series GR1.8).

Tabela 7. Poređenje eksperimentalnih i teorijskih rezultata
Table 7. Comparison of experimental and theoretical results

Test serija <i>Test series</i>	Eksperimentalno ispitivanje <i>Experimental results</i>	Analitički proračun <i>Analytical results</i>	Razlika (%) <i>Difference (%)</i>
Granični moment savijanja (kNm) <i>Flexural capacity (kNm)</i>			
GR0.5	53,8	56,0	4,1
GR1.0	54,5	58,4	7,2
GR1.8	61,8	60,9	1,5
Krutost na savijanje EI (10^3 kNm ²) <i>Flexural stiffness EI (10^3 kNm²)</i>			
GR0.5	2,12	1,89	10,8
GR1.0	2,10	1,96	6,7
GR1.8	2,16	2,03	6,0

Kao što se vidi iz rezultata, analitički proračun daje zadovoljavajuće predviđanje, što znači da može biti primenjen u realnim proračunskim situacijama. Odstupanja koja se javljaju između vrednosti dobijenih u eksperimentalnom ispitivanju i analitičkim proračunom mogu se objasniti malim brojem uzoraka na kojima su izvršeni eksperimenti (tri po seriji), zatim prirodnom varijabilnošću karakteristika drveta i kvalitetom izvođenja ojačanja. Takođe, na rezultate utiče i faktor povećanja graničnih dilatacija čiji uticaj je potrebno dodatno istražiti.

As it is seen from the results analytical model provides good predictions, which means it can be successfully employed for the design of reinforced timber beams. Differences between the values obtained from the experiment and analytical calculation can be explained by a small number of experimental samples (three per series), natural variability of timber properties and processing quality. Also, the results are dependent from ultimate strain modification factor whose influence needs further examination.

5 ZAKLJUČAK

Istraživanja u oblasti ojačanja drvenih konstrukcija primenom FRP šipki postala su aktuelna poslednjih godina i još uvek su malobrojna u odnosu na istraživanja ojačanja primenom FRP traka. U ovom radu su prikazana sva značajnija eksperimentalna ispitivanja koja se bave ovom temom, s ciljem upoznavanja naučne i stručne javnosti s mogućnostima primene FRP šipki kao ojačanja drvenih nosača. Pored toga, dat je i proračunski model kojim se može odrediti krutost i granična nosivost ojačanih nosača.

Primena FRP šipki kao materijala za ojačanje drvenih elemenata pruža velike mogućnosti kod sanacije postojećih konstrukcija, ali i kod projektovanja novih objekata. Ova tehnika omogućava značajno povećanje nosivosti i krutosti ojačanih konstrukcijskih elemenata. Takođe, čini konstrukciju pouzdanijom, redukujući mogućnost pojave krkog loma. Prisustvo FRP ojačanja sprečava otvaranje pukotina, ograničava lokalna oštećenja i premošćava lokalne defekte u drvetu.

Bez obzira na visoke mehaničke karakteristike i druge pogodnosti, posebnu pažnju treba obratiti na pitanje trajnosti, funkcionalnosti i ekonomičnosti, što se postiže pravilnim izborom i primenom odgovarajućeg

5 CONCLUSION

Studies of FRP bars as reinforcement for timber structures have become popular in recent years and there are still a small number of them compared to studies of FRP plates as timber structures reinforcement. This paper presents all significant experimental tests that deal with this topic, with the aim of informing the scientific and professional public with the possibilities of application of FRP bars as reinforcement of timber beams. In addition, theoretical model that determines the stiffness and ultimate moment capacity of reinforced beams is given.

The use of FRP bars as reinforcement for timber elements provides many possibilities for rehabilitation of existing structures, but also for the design of new structures. This method allows for a significant increase in strength and stiffness of reinforced structural elements. In addition, the structure is more reliable due to the reduced possibility of brittle failure. The presence of the FRP reinforcement prevents cracks initiation, limits local damages and bridges local defects in timber.

Despite high mechanical properties and other benefits of this reinforcement method, special attention should be paid to the issue of sustainability, functionality

sistema. Buduća istraživanja treba da utvrde uticaj tipa, položaja i površine ojačanja na nosivost i krutost drvenih elemenata kako za granično stanje nosivosti, tako i za granično stanje upotrebljivosti. Osim toga, da bi ovaj metod ojačanja bio praktičan i ekonomičan za svakodnevnu primenu, potrebno je usavršiti proračunski postupak i implementirati ga u odgovarajući standard.

ZAHVALNOST:

Ovaj rad je proistekao iz istraživačkog projekta TR36048: „Istraživanje stanja i metoda unapređenja građevinskih konstrukcija sa aspekta upotrebljivosti, nosivosti, ekonomičnosti i održavanja”, koji finansira Ministarstvo prosvete, nauke i tehnološkog razvoja Republike Srbije.

6 LITERATURA REFERENCE

- [1] Folić R, Glavardanov D.: „Mehanizmi oštećenja, modeli održavanja i sanacija betonskih konstrukcija pojačanih FRP elementima”, Građevinski materijali i konstrukcije 2009; 52(1), 63–73.
- [2] Radovanovic Z, Dimovski S, Lalosevic I.: *Strengthening masonry walls made of brick blocks with FRCM composites*. Građevinski materijali i konstrukcije 2015;58:21–37.
- [3] Raftery GM, Kelly F. *Basalt FRP rods for reinforcement and repair of timber*. Compos Part B Eng 2015;70:9–19.
- [4] André A.: *Benefits of strengthening timber with fibre-reinforced polymers*, Chalmers University of Technology, 2011, Gothenburg, Sweden.
- [5] Lopresto V, Leone C, De Iorio I. *Mechanical characterisation of basalt fibre reinforced plastic*. Compos Part B Eng 2011;42:717–23.
- [6] Glišović I.: „Teorijska i eksperimentalna analiza nosača od lepljenog lameliranog drveta ojačanih karbonskim trakama”, doktorska disertacija, Građevinski fakultet, Univerzitet u Beogradu, 2013, Beograd, Srbija.
- [7] Banthia N, Bisby L a, Cheng R, Fallis G, Hutchinson R, Mufti A, et al. *ISIS Educational Module 2: An Introduction to FRP Composites for Construction*. ISIS Canada Educ Modul 2006.
- [8] Gentile C, Svecova D, Rizkalla SH. Timber beams strengthened with GFRP bars: development and applications. J Compos Constr 2002;6:11.
- [9] Svecova D, Eden RJ. Flexural and shear strengthening of timber beams using glass fibre reinforced polymer bars - an experimental investigation. Can J Civ Eng 2004;31:45–55.
- [10] Amy K, Svecova D. Strengthening of dapped timber beams using glass fibre reinforced polymer bars 2004;955:943–55.
- [11] Borri A, Corradi M, Grazini A. *A method for flexural reinforcement of old wood beams with CFRP materials*. Compos Part B Eng 2005;36:143–53.
- [12] Micelli F, Scialpi V, La Tegola A. Flexural reinforcement of glulam timber beams and joints with carbon fiber-reinforced polymer rods. J Compos Constr 2005;9:337–47.
- [13] Johnsson H, Blanksvärd T, Carolin a. *Glulam members strengthened by carbon fibre reinforcement*. Mater Struct 2006;40:47–56.
- [14] Raftery GM, Whelan C. Low-grade glued laminated timber beams reinforced using improved arrangements of bonded-in GFRP rods. Constr Build Mater 2014;52:209–20.
- [15] Franke S, Franke B, Harte AM. Failure modes and reinforcement techniques for timber beams – State of the art. Constr Build Mater 2015;97:2–13.
- [16] Yang H, Liu W, Lu W, Zhu S, Geng Q. Flexural behavior of FRP and steel reinforced glulam beams: Experimental and theoretical evaluation. Constr Build Mater 2016;106:550–63.

ACKNOWLEDGEMENT:

This paper resulted from the research project TR36048 'Research on civil structures condition assessment and methods improvement in terms of serviceability, capacity, economy and maintenance funded by the Ministry of Education, Science and Technological Development of Republic of Serbia.

REZIME

OJAČANJE DRVENIH GREDA PRIMENOM FRP ŠIPKI

*Marija TODOROVIĆ
Boško STEVANOVIĆ
Ivan GLIŠOVIĆ*

Potreba da se ojačaju drvene konstrukcije usled oštećenja ili promene namene objekata dovela je do razvoja savremenih metoda ojačanja i upotrebe novih materijala u tu svrhu. Poslednjih godina, upotreba polimera ojačanih vlaknima (FRP) u oblasti sanacija i ojačanja građevinskih konstrukcija omogućena je zahvaljujući povećanoj dostupnosti i sve nižoj ceni. U radu se razmatra mogućnost primene FRP šipki kao materijala za ojačanje drvenih nosača. Ojačanjem drveta kompozitima na bazi karbonskih, staklenih ili bazaltnih vlakana mogu se obezbediti bolje karakteristike, kao što su poboljšana nosivost, krutost i duktilnost. Takođe, u radu je opisan i proračunski model razvijen za predviđanje nosivosti i krutosti drvenih nosača ojačanih FRP šipkama.

Ključne reči: drveni nosači, ojačanje, FRP kompoziti, FRP šipke

SUMMARY

STRENGTHENING OF TIMBER BEAMS USING FRP BARS

*Marija TODOROVIC
Bosko STEVANOVIC
Ivan GLISOVIC*

The growing need for the reinforcement of timber beams (required due to deterioration or damage to the material or change of use) has led to the development of new methods of reinforcement with modern materials. In the recent years the use of fibre reinforced polymers (FRP) as reinforcement materials for structures has been made possible thanks to the increased availability and lower costs. This paper presents FRP bars as products for strengthening timber structures. Strengthening timber with glass, carbon and basalt FRP can provide better features of timber beams, such as improved load capacity, rigidity and ductility. Also, the paper describes the theoretical model developed in order to predict the flexural capacity and flexural stiffness of timber beams reinforced with FRP bars.

Key words: timber structures, strengthening, FRP composites, FRP bars

KAKO SMANJITI RIZIK U PROCESU DOKAZIVANJA KVALITETA GRAĐEVINSKIH PROIZVODA

STRENGTHENING OF TIMBER BEAMS USING FRP BARS

Sonja ČEREPNALKOVSKA
Ljubica VLADIČESKA

STRUČNI RAD
PROFESSIONAL PAPER
UDK:691:658.56(497.7)
doi: 10.5937/grmk1701065C

1 UVOD

U inženjerstvu rizik se koristi za opisivanje prirodnih/slučajnih pojava, odnosno neizvesnosti od njihove pojave. Rizik se definiše kao rezultat verovatnosti i ugroženosti od neke pojave, zajedno s posledicama. Rizik je interakcija intenziteta opasnosti, izloženosti i otpornosti.

Zemljotresi, poplave ili uragani (koji su postojali u antičkom dobu) postaju sve ozbiljniji, budući da se civilizacija sve više razvija. Sve veća šteta, kako ljudska tako i materijalna, pokazuje koliko je ozbiljan ovaj problem, a cilj jeste da se izbegnu sve izraženije katastrofe u svetu.

Tehnički standardi definišu i nalažu stepen sigurnosti objekata, koji zavisi od njihove kategorije. Uobičajeno, te vrednosti su više za objekte javnog karaktera, a niže za individualne objekte. Međutim, tehnički standardi takođe definišu kriterijume koje građevinski proizvodi treba da ispunjavaju da bi odgovorili svojoj nameni, da omoguće objektima da zadovolje osnovne zahteve koji su dati u Regulativi - Construction Products Regulation CPR.

Svi proizvodi pojedinačno drugačije doprinose bezbednosti objekta – neki su važniji (na primer, noseći elementi, krov, vrata za zaštitu od požara...), dok ostali nisu toliko važni (unutrašnja vrata, obloženi paneli...). CPR predviđa pet različitih sistema za ocenu i potvrdu postojanosti svojstava građevinskih proizvoda (Assesment and Verification of Constancy of Performance

PhD. Sonja Čerepnalkovska
Institut za standardizaciju Republike Makedonije – ISRM,
Jurij Gagarin 15, 1000 Skopje, Republika Makedonija
e-mail: cerepnalkovska.sonja@isrm.gov.mk
M. Sc. Ljubica Vladičeska
Fabrika cementa "Usje" TITAN Cement Group AD
Boris Trajkovski 94, Skopje, Republika Makedonija
e-mail: ljupkav@usje.com.mk

1 INTRODUCTION

In engineering, risk is used to describe natural/accidental events or uncertainty of their occurrence. Risk is defined as the result of the probability and vulnerability of some phenomena, together with the consequences. Risk is the interaction of intensity of danger, exposure and resistance.

Earthquakes, floods or hurricanes (which existed in ancient times) are becoming more serious, since civilization has developed. The increasing damage, both human and material, shows the importance of the seriousness of this problem, in order to avoid ever more present disasters in the world.

Technical standards define and dictate the level of safety of the facilities, which depends on their category. Typically, these values are higher for public facilities, and lower for individual buildings. However, technical standards also define the criteria that building products should meet in order to be suitable for their purpose, to ensure that the facilities meet the basic requirements that are set out in the Regulation - Construction Products Regulation - CPR.

All products individually in a different manner contribute to the safety of the facility - some are more important (for example, supporting elements, roof, fire protection doors...), while others are not so important (interior doors, covered panels ...). CPR includes five different systems for assessment and verification of

PhD. Sonja Čerepnalkovska
Standardization Institute of the Republic of Macedonia –
ISRM, Jurij Gagarin 15, 1000 Skopje, Republic of
Macedonia, e-mail: cerepnalkovska.sonja@isrm.gov.mk
M. Sc. Ljubica Vladičeska
Cementarnica "Usje" TITAN Cement Group AD
Boris Trajkovski 94, Skopje, Republic of Macedonia
e-mail: ljupkav@usje.com.mk

AVCP). Svi sistemi su kombinacija zadataka koje obavljaju proizvođači i treća lica ili tela za ocenjivanje usaglašenosti.

Infrastruktura kvaliteta je od suštinskog značaja i predstavlja sastavni deo ekonomije i jedan je od temelja nacionalne, regionalne i međunarodne trgovine. Sistem infrastrukture kvaliteta podrazumeva: standardizaciju, metrologiju, akreditaciju, ocenjivanje usaglašenosti i nadzor tržišta.

Ocenjivanje usaglašenosti pomaže da se obezbedi sigurnost da proizvodi i usluge ispunjavaju očekivanja, što će reći: ocenjivanje usaglašenosti gradi poverenje. Ocenjivanjem usaglašenosti potrošačima se obezbeđuje da proizvode biraju na osnovu izveštaja sa ispitivanja i sertifikata izdatih od specijalizovanih laboratorija i sertifikacionih tela. Tipične aktivnosti ocenjivanja usaglašenosti jesu: uzimanje primeraka, laboratorijska ispitivanja, inspekcije, ocenjivanje, verifikacija i obezbeđivanje deklaracije, sertifikacija, kao i njihove kombinacije.

2 TELA ZA OCENJIVANJE USAGLAŠENOSTI SAGLASNO REGULATIVI - CPR

Evropski parlament i Evropski savet su 9. maja 2011. godine usvojili Regulativu 305/2011 za građevinske proizvode (Construction Products Regulation CPR), koja je u potpunosti obavezujuća i direktno primenjiva u svim zemljama članicama, od 1. jula 2013. godine, dok je Direktiva (Construction Products Directive) br. 89/106/EEC – ukinuta.

Regulativa sadrži odredbe za ocenjivanje usaglašenosti koje su uključene u proces usaglašenosti, a koje će biti ovlašćene za izvršavanje zadataka za treće strane u procesu ocene i potvrde postojanosti svojstava (AVCP) prema ovoj regulativi.

2.1 Tela za laboratorijska ispitivanja – ISO/IEC 17025

Laboratorijsko ispitivanje je jedna od aktivnosti ocenjivanja usaglašenosti. Obezbeđivanje kvaliteta laboratorijskih rezultata omogućuje se akreditacijom laboratorija u skladu sa standardom MKC EN ISO/IEC 17025 – Opšti zahtevi za kompetentnost laboratorija za testiranje i kalibraciju. Tela za akreditaciju laboratorija koriste standard MKC EN ISO/IEC 17025, s ciljem da ocene specifične faktore koji utiču na tehničku kompetentnost laboratorija i to: (1) tehnička kompetentnost zaposlenih; (2) validnost i adekvatnost metoda za ispitivanje; (3) preglednost merenja i kalibracija u saglasnosti sa nacionalnim standardima; (4) adekvatnost, kalibracija i održavanje opreme; (5) uzimanje, rukovanje i transport primeraka za ispitivanje; i (6) obezbeđivanje kvaliteta rezultata ispitivanja i kalibracije. Ovaj standard se sastoji od dva modula: (1) zahtevi za upravljanje laboratorijom (poglavlje 4); (2) tehnički zahtevi za kompetentnost laboratorija (poglavlje 5). Saglasno klauzuli 5.9, važan način ispunjavanja zahteva u oblasti obezbeđivanja kvaliteta laboratorijskih rezultata jeste testiranje sposobnosti laboratorija.

Za poboljšanje kvaliteta rezultata testiranja i kalibra-

constancy of the properties of building products (Assessment and Verification of Constancy of Performance - AVCP). All systems are a combination of tasks that are performed by manufacturer and by third parties or conformity assessment bodies.

Quality infrastructure is of vital importance and represents an integral part of economy and is one of the foundations of national, regional and international trade. The infrastructure quality system includes: standardization, metrology, accreditation, conformity assessment and market inspection.

Conformity assessment helps ensure that products and services deliver on their promises, in other words, conformity assessment builds trust. Conformity assessment ensures that the consumers select products on the basis of reports from the tests and certificates issued by specialized laboratories and certification bodies. Typical activities of conformity assessment are: taking samples, laboratory testing, inspection, assessment, verification and provision of declaration, certification, and combinations thereof.

2 CONFORMITY ASSESSMENT BODIES REGARDING CONSTRUCTION PRODUCTS REGULATION CPR

The European parliament and the Council on 9 March 2011 adopted REGULATION No 305/2011-(Construction Products Regulation CPR), laying down harmonized conditions for the marketing of construction products and repealing Council Directive 89/106 EEC-CPD. The Regulation 305/2011 applied from 1 July 2013.

The Regulation includes provisions for conformity assessment that are included in the process of conformity, and which will be authorized to carry out tasks for third parties in the process of assessment and verification of constancy of properties (AVCP) under this Regulation.

2.1 Body for laboratory testing -ISO/IEC 17025

Laboratory testing is one of the conformity assessment activities. Quality assurance of laboratory results is accomplished by accreditation of the laboratories according to the standard ISO/IEC 17025:2005 - General requirement for the competence of testing and calibration laboratories. Laboratory accreditation bodies use ISO/IEC 17025, specifically to assess factors relevant to the laboratory technical competence, including the:(1) technical competency of staff; (2) validity and suitability of test methods; (3) traceability of measurements and calibrations to national standards;(4) suitability, calibration and maintenance of testing equipment; (5) sampling, handling and transportation of test items, and (6) quality assurance of test and calibration data. This standard consists of two modules: (1) laboratory management requirements (clause 4 from the standard) ;(2) technical requirements for competence of laboratories (clause 5 from the standard). Regarding of ISO/IEC 17025 (clause 5.9) in the area of quality assurance of laboratory results, important way of meeting the requirements is Proficiency testing (comparative testing).

Officially, by the end of 2010, for the improvement of

cije do kraja 2010. godine, zvanično su korišćena dva tipa međunarodnih dokumenata i to: za interno obezbeđivanje kvaliteta (IQA) – ISO / IEC 17025 i za eksterno obezbeđivanje kvaliteta (EQA) – ISO / IEC Uputstvo 43 i ILAC G13. Od početka 2011. godine, za eksterno obezbeđivanje kvaliteta laboratorijskih rezultata primenjuje se međunarodni standard MKC EN ISO/IEC 17043 – ocenjivanje usaglašenosti – Opšti zahtevi za testiranje osposobljenosti. Testiranje osposobljenosti (uporedno ispitivanje) bitan je način ispunjavanja zahteva ISO / IEC 17025 (klauzula 5.9) u oblasti obezbeđivanja kvaliteta laboratorijskih rezultata. Takođe, tela za akreditaciju obavezuju laboratorije da učestvuju u testiranju osposobljenosti u odgovarajućim programima za sve vrste analiza koje se vrše u toj laboratoriji. Testiranje osposobljenosti uključuje grupu laboratorija ili analitičare koji rade iste analize na istim primercima i dobijaju uporedne rezultate. Ključni zahtevi ovih poređenja su da primerci budu homogeni i stabilni, a grupa primeraka koja se analizira treba da bude odgovarajuća za ispitivanje i prikazivanje sličnosti i razlika u rezultatima.

2.2 Sertifikaciona tela za proizvode – ISO/IEC 17065:2012

Sertifikacija proizvoda je sredstvo koje obezbeđuje sigurnost da je proizvod usaglašen sa specifičnim zahtevima, navedenim u standardima i standardizacijskim dokumentima. Iako se ovaj standard odnosi na tela koja rade kao treća strana, mnoge od ovih odredaba mogu da se koriste i kod tela koja rade kao prva i druga strana, u njihovim unutrašnjim procedurama za ocenu usklađenosti proizvoda.

Donedavno su ISO/IEC Uputstvo 65:1996 i Opšti zahtevi tela za sertifikaciju proizvoda omogućavali da se ovi sertifikati sprovode na kompetentan i fer način. Sada novi standard obećava da će se ovaj proces podići na viši nivo. Tekst Uputstva je u potpunosti revidiran, dokazani delovi su zadržani i poboljšani tamo gde je bilo potrebno i kao rezultat revizije objavljen je novi standard ISO/IEC 17065:2012, Ocenjivanje usaglašenosti – Zahtevi za tela koja sertifikuju proizvode, procese i usluge. Novi standard jasno ukazuje na to da sertifikacija proizvoda može da se primeni i na procese i na usluge. Novi informativni aneks (Annex A) pokazuje kako standard može da bude specifično interpretiran samo za procese i usluge. Novi aneks identifikuje principe kojima se rukovode tela za sertifikaciju proizvoda kao i njihove aktivnosti. Ti principi inspirišu poverenje u proces sertifikacije. Ključne reči su nepristrasnost, kompetentnost, poverljivost i otvorenost, odgovaranje prema prigovorima i žalbama, i odgovornost. Mnogi od zahteva ISO/IEC 17065 razjašnjeni su i bazirani na povratnim informacijama iz dugogodišnjeg iskustava i formalnih tumačenja ISO/IEC Uputstva 65. Koncept koji se često spominje u ISO/IEC 17065 jesu sertifikacione šeme. Njima se obuhvataju svi specifični zahtevi, pravila i procedure koje se odnose na proizvod (ili grupu proizvoda) da bi oni bili sertifikovani.

the quality of test and calibration results, two sets of international documents were used: for internal quality assurance (IQA) - ISO/IEC 17025; for external quality assurance (EQA) -ISO/IEC Guide 43 and ILAC G13. Since the end of 2010, for the purpose of external quality assurance, the international standard ISO / IEC 17043:2010 - Conformity assessment, General requirements for proficiency testing - has been used. Proficiency testing (comparative testing) is an important way of meeting the requirements of ISO/IEC 17025 (clause 5.9) in the area of quality assurance of laboratory results. It is also mandated by accreditation bodies that laboratories participate in proficiency testing and, when they exist, suitable programs for all types of analyses undertaken in that laboratory. Proficiency testing involves a group of laboratories or analysts performing the same analyses on the same samples and comparing results. The key requirements of such comparisons are that the samples are homogenous and stable, and also that the set of samples analyzed are appropriate to test and display similarities and differences in results.

2.2 Certification body for product - ISO/IEC 17065:2012

Product certification is a tool that provides assurance that the product conforms to the specific requirements set out in standards and standardization documents. Although this standard applies to the bodies operating as a third party, many of these provisions can be used also with bodies operating as first and second sides, in their internal procedures for assessing the conformity of products.

Until recently, the ISO/IEC Guide 65:1996 and the General requirements for product certification bodies allowed these certificates to be conducted in a competent and fair manner. General requirements for product certification allowed these certificates to be implemented in a competent and fair manner. Now a new standard promises to take this process to the next level. The text of the Guide has been completely revised, proven parts are retained and improved where needed and as a result the revision was released a new standard ISO/IEC 17065:2012, Conformity assessment - Requirements for bodies certifying products, processes and services. The new standard clearly indicates that the certification of products can be applied both to processes and services. The new informative annex (Annex A) shows how the standard can be specifically interpreted only for processes and services. The new annex identifies the principles that govern the product certification bodies as well as their activities. These principles inspire confidence in the certification process. Keywords are impartiality, competence, confidentiality and openness, responding to complaints and appeals, and responsibility. Many of the requirements of ISO/IEC 17065 are clarified and based on feedback from many years of experience and formal interpretation of ISO/IEC Guide 65. The concept that is often mentioned in the ISO/IEC 17065 is certification schemes. They include all specific requirements, rules and procedures relating to a product (or a group of products) in order to be certified.

3 METODOLOŠKO ISTRAŽIVANJE

Sprovedeno je empirijsko istraživanje stavova rukovodstva i zaposlenih u laboratorijama. Istraživanje je sprovedeno na 21 primerku, dok je u radu data samo analiza akreditovanih laboratorija za testiranje iz sektora građevinarstva. Istraživanje je sprovedeno jedino u akreditovanim laboratorijama zato što su u ovom trenutku akreditovana samo dva sertifikaciona tela za građevinske proizvode i to jedno u junu, a drugo telo u decembru 2016. godine.

Cilj istraživanja je: (1) da se dobije jasan uvid u celokupno stanje laboratorija u odnosu na njihovu akreditaciju i njihovo učešće u međulaboratorijskim poređenjima; (2) definisanje benefita od njihove akreditacije i međulaboratorijskih poređenja; (3) lociranje problema i prepreka s kojima se suočavaju laboratorije pri implementaciji zahteva specificiranih u standardu MKC EN ISO/IEC 17025; (4) ocena ekonomske opravdanosti akreditacije. Implementacija standarda nije jednostavan proces, međutim njihovom primenom se postiže efektivno i efikasno funkcionisanje laboratorije, kao i postizanje željenih rezultata.

3.1 Prikaz elemenata upitnika

Anketa je projektovana tako da obuhvata pitanja primene standarda MKC EN ISO/IEC 17025 i MKC EN ISO/IEC 17043. Istovremeno, anketa obuhvata pitanja o upravljanju i organizaciji rada (implementiran MKC EN ISO 9001), finansijskoj opravdanosti, sugestijama i preporukama za unapređivanje rada organizacija u savremenim tržišnim uslovima. Istraživanje stavova predstavnika rukovodstva laboratorija izvršeno je u periodu od novembra 2012. do marta 2015. godine, na teritoriji Republike Makedonije, kako bi se dobila mišljenja rukovodilaca i zaposlenih koji se bave laboratorijskim ispitivanjima.

Upotrebom statističkih metoda u analizi odgovora i kreiranjem dijagrama i tabela, dobijen je određeni niz stavova koji oslikavaju realno stanje u zemlji u odnosu na akreditovane laboratorije i njihovo učešće u međulaboratorijskim poređenjima.

Prvi deo upitnika je usmeren na tačku 4 standarda MKC EN ISO/IEC 17025. Odnosi se na merenje stepena poboljšanja u procesu elemenata povezanih s menadžmentom u laboratoriji: (1) upravljanje dokumentima; (2) zadovoljstvo klijenata; (3) upravljanje ljudskim resursima i (4) upravljanje procesima.

Drugi deo upitnika je usmeren na tačku 5 standarda MKC EN ISO/IEC 17025 kompetencija laboratorije. Odnosi se na merenje stepena: (1) učešća u međulaboratorijskim ispitivanjima; (2) učešća u RT šemama; (3) uspostavljanja i razvijanja PT šema i (4) akreditovanih PT šema.

3 METHODOLOGICAL RESEARCH

Empirical survey of the views of management and employees in laboratories was carried out. The survey was carried out on 21 samples, and the paper presents only the analysis of accredited testing laboratories in the construction sector.

The survey was carried out only in accredited laboratories for the reasons that at the moment only two certification bodies are accredited for construction products; one in June and the other body in December 2016.

The purpose of this research is to: (1) gain a clear understanding of the overall state of laboratories in terms of their accreditation and participation in inter-laboratory comparisons; (2) define the benefits of their accreditation and participation in inter-laboratory comparisons, and (3) locate the problems and obstacles they are facing in implementation of relevant requirements specified in the standard ISO/IEC 17025 (4) assessment of economic justification of the accreditation. The implementation of the standards is not an easy process, although it contributes to the effective and efficient functioning of laboratories and achievement of desired results.

3.1 Representation of the questionnaire elements

The questionnaire was designed in a way to cover issues of implementation of the standard ISO/IEC 17025 and ISO/IEC 17043. At the same time, the questionnaire includes questions about management and organization of work (implemented ISO 9001), as well as financial viability, and suggestions and recommendations for improvement in the organization of work in modern market conditions. A survey of the views of the representatives of the management of laboratories is conducted in order to get the opinion of managers and employees who are engaged in laboratory testing. This survey was carried out during the period from November 2012 to March 2015 in the territory of the Republic of Macedonia.

Using statistical methods in the analysis of responses and creating diagrams and charts, a range of views were received, which reflect the real situation in the country in terms of accredited laboratories and their participation in interlaboratory comparisons.

The first part of the questionnaire is directed towards point 4 of the standard ISO/IEC 17025. It refers to the measurement of the improvement level in the process related to the management of the laboratory: (1) document management; (2) customer satisfaction; (3) human resource management; (4) management processes.

The second part of the questionnaire is directed towards point 5 of the standard ISO/IEC 17025:2005, the competence of the laboratory. It refers to the measurement of the degree of: (1) participation in interlaboratory comparisons; (2) participation in PT schemes; (3) the establishment and development of PT schemes; (4) accredited PT schemes.

4 ANALIZA REZULTATA

Prema zvaničnim podacima Instituta za akreditaciju Republike Makedonije (IARM), u Republici Makedoniji postoje 142* akreditovana tela za ocenu usklađenosti iz 110* organizacija. Pregled akreditovanih tela za ocenu usklađenosti dat je u tabeli 1.

4 ANALYSES OF RESULTS

According to the official data of the Institute for Accreditation of the Republic of Macedonia (IARM), in the Republic of Macedonia there are 142* accredited bodies for conformity assessment of 110* organizations. Overview of accredited bodies for conformity assessment is given in Table 1.

Tabela 1. Pregled akreditovanih tela za ocenjivanje usaglašenosti
Table 2. Overview of accredited bodies for conformity assessment

Tela za ocenjivanje usaglašenosti / Conformity assessment bodies		N	Ukupno Total
Laboratorije / Body for laboratory testing (MKC EN ISO/IEC 17025/ MKC ISO 15189)	za ispitivanje / for testing	66	75
	etaloniranje / calibration	8	
	medicinske laboratorije medical laboratories	1	
Tela za sertifikaciju / Certification body (MKC EN ISO/IEC 17021/ MKC EN ISO/IEC 17065)	sistema menadžmenta kvalitetom quality management systems	1	3
	proizvoda / products	2	
Inspeksijska tela / Inspection body (MKC EN ISO/IEC 17020)		64	64

Od ukupno 66 laboratorija za testiranje, najzastupljenije su laboratorije u oblasti hemije (43,9%), dok su prema vrsti proizvoda/materijala za testiranje najzastupljenije u životnoj sredini i primerci iz životne sredine (30,3%). Od ukupnog broja laboratorija za testiranje, šest laboratorija je iz oblasti građevinskog sektora, što predstavlja zastupljenost od 9,1% prema vrsti proizvoda/materijala – građevinskog proizvoda, materijala i konstrukcije. Prema navedenom, građevinski proizvodi, materijali i konstrukcije rangiraju se kao treća najzastupljenija vrsta proizvoda/materijala za testiranje.

Pregled procentualne zastupljenosti laboratorija prema vrsti proizvoda dat je u tabeli 2, dok je zastupljenost akreditovanih laboratorija prema vrsti proizvoda iz oblasti građevinarstva prezentovana u tabeli 3.

From a total of 66 testing laboratories the most common are laboratories in the field of chemistry (43.9%), while according to the type of testing products/materials the greatest number of laboratories are in the environment sector and samples from the environment (30.3%). Of the total number of testing laboratories, 6 laboratories are operating in the areas of the construction sector, which is a representation of 9.1% according to the type of product/material - building products, materials and structures. According to the previously mentioned, building products, materials and structures are ranked as the third most common type of products/materials for testing.

Overview of the percentage share of laboratories according to the type of product is given in Table 2, while the representation of accredited laboratories according to the type of product in the construction sector is presented in Table 3.

Tabela 2. Zastupljenost laboratorija prema vrsti proizvoda/materijala za testiranje
Table 2. Representation of laboratories according to types of products/materials for testing

Vrsta proizvoda materijala za testiranje Types of products/materials for testing	Bioološki primerci Biological samples	Građevinski proizvodi, materijali i konstrukcije Construction products, materials and structures	Električni proizvodi i oprema Electrical products and equipment	Ind. materijali i proizvodi Industrial materials and products	Životna sredina i primerci iz životne sredine Environment and samples from the environment	Hrana / Foodstuffs	Goriva, sredstva za podmazivanje i industrijska ulja Fuels, lubricants and industrial oils	Nameštaj / Furniture	Tekstil i koža Textile and leather	Predmeti za opštu upotrebu Objects of general use	Medicinski proizvodi Medical products	Poljoprivredni proizvodi Agricultural products	Ostalo / Others
N	4	6	1	2	20	14	2	1	1	1	2	5	3
% Zastuplj. represent.	6,1	9,1	1,5	3,0	30,3	21,2	3,0	1,5	1,5	1,5	3,0	7,5	4,5

* Stanje zaključno u junu 2015.

* Condition end June 2015.

Tabela 3. Zastupljenost laboratorija prema vrsti proizvoda/materijala za testiranje u građevinskom sektoru
Table 3. Representation of laboratories according to types of products/materials for testing in construction sector

Vrsta proizvoda/ materijala za testiranje Types of products / materials for testing	Cement / Cement	Beton / Concrete	Kamen i agregati Stone and aggregate	Stene i zemlja Stone and soil	Cigle / Masonry unit	Keramika / Ceramics	Vatrootalni materijali i proizvodi Refractory materials and products	Asfalt bitumeni Bituminous mixtures	Toplotnoizolacioni materijali Thermal insulation materials	Konstrukcije / Structures	Građevinski proizvodi Construction Products	Građevinska stolarija i proizvodi od drveta Wood products
N	2	3	2	4	1	1	0	2	0	3	1	1

Pregled broja akreditovanih laboratorija po određenim metodama za ispitivanje građevinskih proizvoda u skladu s makedonskim standardima dat je u tabelama 4, 5 i 6. Prema navedenom, najzastupljenije su metode za ispitivanje cementa, betona, agregata i tla.

Overview of the number of accredited laboratories according to certain methods of testing of construction products in accordance with Macedonian standards is given in Tables 4, 5 and 6. According to this, the most common are the methods for testing of cement, concrete, aggregates and soil.

Tabela 4. Prikaz broja akreditovanih laboratorija u sektoru: beton, čelik, cement i građevinska hemija
Table 4. Overview of the number of accredited laboratories in the sectors: concrete, steel, cement and building chemicals

SEKTOR-BETON, ČELIK, CEMENT I GRAĐEVINSKA HEMIJA SECTOR-CONCRETE, STEEL, CEMENT AND BUILDING CHEMICALS									
METODE (po seriji standarda) Methods for series of standards	MKC EN 12350 ispitivanja svežeg betona Testing fresh concrete	MKC EN 12390 ispitivanja očvrlog betona Testing hardened concrete	MKC EN 12504 ispitivanje betonskih konstrukcija Testing concrete in structures	MKC EN 196 ispitivanje cementa Methods of testing cement	MKC EN 413 zidarski cement Masonry cement	MKC EN 480 -aditivi za beton Admixtures for concrete	MKC EN 1008 voda za pripremu betona Mixing water for concrete	MKC EN 451 ispitivanje letećeg pepela Method of testing fly ash	MKC EN 15630 betonski čelik i čelik za prethodno naprezanje betona Steel for the reinforcement and prestressing of concrete
Br. labor. No. lab.	3	3	3	3	1	2	2	1	3

Tabela 5. Prikaz broja akreditovanih laboratorija u sektoru: agregat, kamen i keramika
Table 5. Overview of the number of accredited laboratories in the sectors: aggregates

SEKTOR-AGREGAT, KAMEN I KERAMIKA / SECTOR- AGGREGATES					
METODE (po seriji standarda) Methods for series of standards	MKC EN 932 agregat Methods for aggregates	MKC EN 933 agregat Methods for aggregates	MKC EN 1097 agregat Methods for aggregates	MKC EN 1367 agregat Methods for aggregates	MKC EN 772 zidarske jedin. Methods of test for masonry units
Br. labor. No. lab.	2	2	2	1	1

Tabela 6. Prikaz broja akreditovanih laboratorija u sektoru: geomehanika, asfalt, bitumen i izolacioni materijali
 Table 6. Overview of the number of accredited laboratories in the sectors: geomechanics, asphalt, bitumen and insulating materials

SEKTOR ZA GEOMEHANIKU, ASFALT I IZOLACIONI MATERIJALI SECTOR - GEOMECHANICS, ASPHALT, BITUMEN AND INSULATING MATERIALS			
METODE (po seriji standarda) <i>Methods for series of standards</i>	MKC EN 12697 asfaltne mešavine <i>Bituminous mixtures</i>	MKC EN 13286 nevezane i hidrauličkim vezivom vezane mešavine <i>Unbound and hydraulically bound mixtures</i>	MKC CEN ISO TS 17892 geotehničko istraživanje <i>Geotechnical investigation and testing</i>
Br. labor. <i>No. lab.</i>	2	4	2

Svi ovi standardi predstavljaju indirektnu podršku zakonskoj regulativi, odnosno Zakonu za građevinske proizvode. Harmonizovani standardi na koje se poziva Zakon, obezbeđuju metode i kriterijume za procenu funkcionalnosti građevinskog proizvoda u vezi s njegovim osnovnim karakteristikama. Za primer ćemo uzeti cement kao najzastupljeniji, krucijalni proizvod u građevinarstvu, koji kao takav, saglasno sistemu za ocenu usklađenosti, nosi sistem „1+”. Makedonski standard MKC EN 197-1:2012 – Cement – Deo 1: Sastav, specifikacije i kriterijumi usklađenosti za obične cimente, jeste harmonizovan standard. Standard MKC EN 197-1 definiše i daje specifikacije za 27 posebnih običnih proizvoda od cementa i njihove sastavne elemente. Definicija za svaki cement uključuje saodnose u kojima sastavni elementi (sastojci) treba da se kombinuju da bi se dobili ovi posebni proizvodi i to u okviru šest klasa jačine. Standard, takođe, uključuje zahteve koje treba da ispunjavaju sastavni elementi kao i mehaničke, fizičke i hemijske zahteve, uključujući, gde je moguće, i zahteve za toplinu hidratacije. Standard, zatim, iznosi i utvrđuje kriterijume za usaglašenost kao i pravila povezana s njima. Usaglašenost 27 proizvoda prema MKC EN 197-1 treba kontinuirano da se evaluira na osnovu ispitivanja pojedinačnih primeraka (uzetih s lica mesta). Svojstva, metode ispitivanja i minimalna učestalost ispitivanja za autokontrolno ispitivanje od strane proizvođača dati su upravo u referiranim standardima (tabela 7). Saglasno tim standardima, radi se laboratorijsko ispitivanje i saglasno istim standardima, laboratorije su akreditovane za odgovarajuće metode. U tabeli koja sledi dat je niz standarda iz serije MKC EN 196, na koje se upravo harmonizovani standard MKC EN 197-1 poziva.

All these standards represent indirect support to the legal regulations, i.e. the Law on construction products. The harmonized standards, to which the law refers, provide methods and criteria for assessing functionality of the construction product in relation to its basic characteristics. For example, we can consider cement as the most common and crucial product in the construction industry which, as such, in accordance with the system of conformity assessment, bears system "1+". Macedonian standards MKS EN 197-1: 2012 - Cement - Part 1: Composition, specifications and conformity criteria for common cements, is a harmonized standard. Standard MKS EN 197-1 defines and provides specifications of 27 special common cement products and their constituent elements. The definition of each cement includes the proportions in which its constituents (ingredients) should be combined in order to achieve these special products within six classes of strength. The standard also includes requirements to be met by constituents as well as mechanical, physical and chemical requirements including, where applicable, the requirements for the heat of hydration. The standard, then, presents and determines the criteria for conformity as well as the rules associated with them. Conformity of 27 products to MKS EN 197-1 should continuously be evaluated on the basis of tests of individual samples (taken from the site). The properties, test methods and minimum testing frequency for auto controlled testing by the manufacturer are given exactly in the referred standards (Table 7). In accordance with these standards laboratory testing is conducted and in accordance with the same standards laboratories are accredited for the appropriate methods. The following table provides a set of standards from the series MKS EN 196, to which the harmonized standard EN 197-1 ICC actually refers.

Tabela 7. Prikaz standarda za ispitivanje cementa
Table 7. Overview of standards for cement

Metode za ispitivanje <i>Methods for testing</i>	Cementi <i>Cement</i>	Svojstva <i>Performance</i>
MKC EN 196-1	Svi / all	Početa čvrstoća <i>Initial strength</i>
MKC EN 196-3	Svi / all	Vremena vezivanja i stalnosti zapremine <i>Determination of setting times and soundness</i>
MKC EN 196-3	Svi / all	Tvrdoća / Hardens
MKC EN 196-2	CEM I, CEM III	Gubitak pri paljenju <i>Loss on ignition</i>
MKC EN 196-2	CEM I, CEM III	Nerastvorljivi ostatak <i>Insoluble residue</i>
MKC EN 196-2	Svi / all	Sadržaj sulfata <i>Sulphate content</i>
MKC EN 196-2	Svi / all	Sadržaj hlorida <i>Chloride content</i>
MKC EN 196-5	CEM IV	Pucolanski <i>Pozzolan</i>
MKC EN 196-8/9	Obični cement s niskom toplotom hidratacije <i>Common cement with low heat of hydration</i>	Topolota hidratacije <i>Thermal hydration</i>

Ovim primerom autori žele da potvrde da implementacija standarda nije jednostavan proces. Evidentno je da laboratorije definišu oblast i metode koje će akreditovati u zavisnosti od postojanja zakonskih okvira. Dakle, ukoliko legislativa definiše određene karakteristike proizvoda koje treba da budu ispitane prema standardnim metodama, onda laboratorije u opsegu akreditacije uključuju samo ove metode. Stiče se utisak da je link zakonodavac-proizvođač determinacioni faktor u definisanju opsega akreditacije, dok su zahtevi klijent/poslovni saradnik-proizvođač u drugom planu.

Međutim, radi obezbeđivanja kvalitetnog proizvoda, obezbeđivanja poverljivih rezultata ispitivanja, zadovoljenja zahteva klijenata, kao i jačanja pozicije na tržištu, laboratorije se upuštaju u proces akreditacije. Ovaj proces nosi određene koristi koje laboratorije iz građevinskog sektora identifikuju kao što je prikazano na slici 3.

Najviše laboratorija izjasnilo se da su primećena vidljiva poboljšanja pri upravljanju dokumentima (17%), te bolja kompetentnost personala (16%), kao što je dato na slici 1.

Akreditacijom laboratorija, u klauzuli 5.9 standarda MKC EN ISO/IEC 17025 postavljeni su zahtevi za učešće u međulaboratorijskim poređenjima. Saglasno sprovedenom istraživanju, laboratorije u građevinskom sektoru 100% ispunjavaju ove zahteve. U građevinskom sektoru, četiri laboratorije (80%) učestvuju u ukupno 21 PT šemi. Važno je istaći da su tri laboratorije iz građevinskog sektora (60%) uspostavile i razvile ukupno deset neakreditovanih PT šema.

With this example the authors wish to acknowledge that implementation of standards is not an easy process. It is evident that laboratories define the area and the methods to be accredited according to the existence of relevant legal framework. Therefore, if legislation defines certain features of the product that should be tested according to standard methods, then the laboratories include only these methods in the scope of accreditation. One gets the impression that the link legislator-manufacturer is the determining factor in the defining of the scope of accreditation, while the demands of client/business associate-manufacturer are pushed into the background.

However, in order to ensure a quality product, reliable test results, satisfaction of customer requirements, as well as strengthen the market position, laboratories are engaged in the process of accreditation. This process carries certain benefits as identified by the laboratories from the construction sector and as shown in Figure 3.

Most laboratories (17%) said they have noticed visible improvements in the management of documents (16%) which improved personnel competence, as shown in Figure 1.

Accreditation of laboratories, in clause 5.9 of the standard MKS EN ISO/IEC 17025, sets out the requirements for participation in inter-laboratory comparisons. In accordance with the conducted research, laboratories in the construction sector 100% meet these requirements. In the construction sector 4 (80%) laboratories participate in a total of 21 PT schemes. It is important to point out that 3 laboratories in the construction sector (60%) have established and developed a total of 10 non-accredited PT schemes.

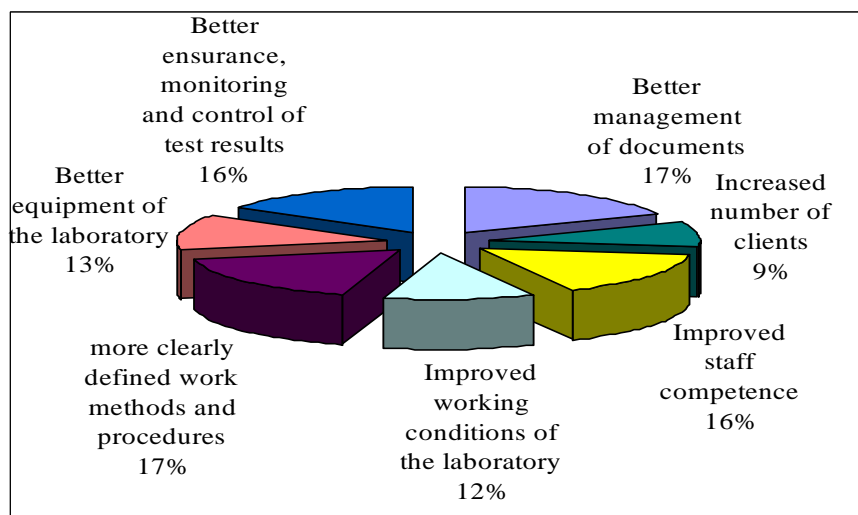

Slika 1. Poboľšanja s procesom akreditacije
Figure 1. Improvements in the laboratories after accreditation

5 NOVINE U STANDARDIZACIJI CEMENTA

Evropski komitet za standardizaciju radi na proširenju palete običnih cementa u okviru palete EN 197-1. Ono što je karakteristično za ove kompozitne cemente jeste veća koncentracija mešavine dveju glavnih komponenti bez klinkera u svom sastavu. Takva vezivna sredstva su izražena u trojnim kombinacijama K-S-L/LL, K-S-V i K-V-L/LL (K – klinker, S – granulirana šljaka iz peći za topljenje materijala, V – silicijumov lebedeći pepeo, L/LL – kreč). Zbog toga će tekući cementni sastavi biti prošireni za dopunsku podgrupu CEM II/C sa uvećanim udelom mineralnih aditiva do 50% i za celu novu grupu kompozitnih cementa CEM IV, u kojima sadržaj portland klinkera neće prevazilaziti 50%. Sadržaj glavnih komponenti bez klinkera u okviru ove grupe biće između 50 i 65%. Posle toga bi grupa CEM V promenila svoje ime od kompozitnih cementa u pucolanske – šljaka cemente.

5 NEW DEVELOPMENTS IN CEMENT STANDARDIZATION

European Standardization Committee is working on widening the range of common cements within the scope of EN 197-1. A characteristic feature of these composite cements is a higher concentration of a mixture of the two non-clinker main components in their composition. Such binders are present in ternary combinations K-S-L/LL, K-S-V and K-V-L/LL (K – clinker, S – granulated blast furnace slag, V – siliceous fly ash, L/LL – lime). Current cement compositions will therefore be extended by an additional subgroup of CEM II/C, with increased share of mineral additives up to 50% and by a whole new group of composite cements CEM IV, of which the content of Portland clinker will not exceed 50%. The content of the main non-clinker components will constitute within this group from 50 to 65 %. Hitherto group of CEM V will then change its name from composite cements into pozzolanic – slag cements.

Tabela 8: Novi tipovi običnih cementa prema pr EN 197-1 (2014) Izvor: (pr EN 197-1, 2014)
Table 8: New types of common cements acc. to pr EN 197-1 (2014)

Tip cementa Cement type	Oznaka Designation		Učešće komponentata u cementu, % po masi Component share in cement, % by mass				
			Klinker K Clinker K	Zgura peći S Blast furnaceslag S	Prirodni pucolan P Natural Pozzolan P	Leteći pepeo V Flay ash V	Kreč L i LL Lime L u LL
CEM II	Portland kompozitni cement	CEM II/C-M (S-L)	50-64	16-44	-	-	6-20
		CEM II/C-M (S-LL)		16-44	-	-	6-20
		CEM II/C-M (P-L)		-	16-44	-	6-20
	Portland composite cement	CEM II/C-M (P-LL)		-	16-44	-	6-20
		CEM II/C-M (V-L)		-	-	16-44	6-20
		CEM II/C-M (V-LL)		-	-	16-44	6-20
		CEM II/C-M (S-V)		16-44	-	6-20	-
CEM VI	Kompozitni cement Composite cement	CEM VI (S-L)	35-49	31-59	-	-	6-20
		CEM VI (S-LL)		31-59	-	-	6-20
		CEM VI (S-V)		31-59	-	6-20	-

Proširenje asortimana kompozitnih cementa opravdava se činjenicom da je nastalo formiranjem njihovih svojstava upotrebom sinergetskog uticaja na primenjene mineralne aditive. Poznato je da efekat individualnih glavnih komponenti bez klinkera na cementna svojstva može da bude različit. Takav jednostavan primer imamo pri uticaju na dodavanje lebedećeg pepela i mlevenog kreča za razvoj čvrstine. Silicijumov lebedeći pepeo usporava razvoj čvrstine na početku stezanja (povezivanja), ali ne smanjuje čvrstinu na duže periode. Kombinacijom različitih mineralnih aditiva u kompozitnim cementima mogu da se koriste njihove povoljne karakteristike, a zatim optimalnim iskorišćavanjem sastava cementne mešavine, efektivno može da se potisne njihov negativan uticaj.

Novembra 2016. godine, izglasana je važna Rezolucija BT N 10528. Predmet ove rezolucije je priprema radnog nacrt – Amandmana na Mandat M/114 na CEN – SRAHG 'CEMENT'. Rok za izglasavanje bio je 22. novembar i trenutno očekujemo rezultate. Cilj ovog radnog nacrt-a-mandmana jeste da se proširi postojeći mandat M/114 koji obuhvata harmonizovane standarde za proizvod, tako da bi mogli da se uključe noviji događaji u istoj proizvodnoj oblasti (na primer, da se uključe dopunski tipovi cementa).

Za dalje postupanje s „Radnim nacrtom-amandmanom na M/114”, Centar za upravljanje CEN – CENELEC (CCMC) imenuje ad-hok grupu (SRAHG 'CEMENT') da bi koordinisao output članova tehničkog odbora (BT) i drugih relevantnih strana i da bi obezbedio blagovremene povratne informacije za vreme pripreme i odobrenja ovog zahteva. SRAHG 'CEMENT' će biti referentna grupa za praćenje priprema i davaće savete u slučaju problematičnih pitanja s kojima će se suočavati Centar za upravljanje CEN – CENELEC (CCMC) i pogođene strane za vreme procesa pripreme i odobrenja (primerice, sadržina, rokovi, resursi koji nedostaju, itd.) tako da blagovremeno može da se podnese relevantan predlog tehničkom odboru (BT).

6 ZAKLJUČAK

Proces akreditacije u Republici Makedoniji počeo je 2006. godine, dok je prva laboratorija iz oblasti građevinarstva akreditovana 2008. godine. Nazvanični podaci pokazuju da je u Republici Makedoniji ukupan broj laboratorija daleko veći od broja akreditovanih laboratorija i otuda proizlazi pitanje zašto je to tako.

Proces akreditacije podrazumeva troškove angažovanja konsultanata i ocenjivača, više vremena za izradu akreditacije, limitirane ljudske resurse, i kada se na to doda trošak za održavanje akreditacije, korišćenje referentnih materijala kao i kalibraciju instrumenata, očigledno je da je akreditacija skup proces. Laboratorije treba da pronađu optimalni način da simultano ispune sve ove zahteve. Cene usluga su niske, a broj klijenata je mali i ne povećava se. Zato je velik broj akreditovanih laboratorija iz javnog sektora koji je finansijski podržan od vlade, dok je industrija predstavljena samo sa 13%. Na tržištu još uvek postoji neloyalna konkurencija tako da je cene usluga akreditovanih laboratorija nemoguće povećati. Istraživanje je pokazalo da laboratorije svojim opsegom akreditacije uključuju uglavnom metode koje su podrška Regulativi što ide u prilog činjenici da proizvođači ciljaju na ispunjavanje osnovnih minimalnih

The expansion of composite cements assortment is justified primarily by the fact that one came, form their properties using the synergy influence effect of the mineral additives applied. It is a common knowledge that the effect of individual non-clinker main components on cement properties, can vary. A simple example of such is the influence of the fly ash and ground limestone addition on strength development. Siliceous fly ash retards the development of strength in early setting times, but do not reduce the strength in longer periods. In contrast, lime accelerates the development of early strength, but reduces the strength in the longer periods of setting. With a combination of various mineral additives in composite cements, it is possible to use their favourable characteristics, furthermore, by optimizing the composition of cement mixture, their adverse impact can be effectively suppressed.

In November 2016 year, very important Resolution BT N 10528 was voted. The Subject of this Resolution is preparing working draft Amendment to the Mandate M/114 to CEN - SRAHG 'CEMENT'. The deadline for vote was 22 of November and now we are waiting for the results. The objective of this working draft amendment is to extend the existing mandate M/114 that cover, harmonized product standards, so recent developments in the same product area could be included (e.g. to include additional types of cement).

To further deal with the "Working draft amendment to M/114", CCMC is setting up an ad-hoc group (SRAHG 'CEMENT') to coordinate input from BT members and other relevant parties and to provide timely feedback, during the drafting and approval of this request. The SRAHG 'CEMENT' will be the reference-group to follow-up the preparatory work and advise in case of problematic issues encountered by CCMC and by the concerned parties during the drafting or approval process (e.g. content, deadlines, missing resources, etc.) so that a relevant proposal can be submitted to the BTs in due time.

6 CONCLUSION

The accreditation process in the Republic of Macedonia began in 2006, while the first laboratory in the field of civil engineering was accredited in 2008. Unofficial data shows that in the RM the total number of laboratories by far exceeds the number of accredited laboratories and hence raises the question of why this is the case?

The accreditation process includes the costs of hiring consultants and evaluators, more time for preparation of accreditation, limited human resources, the cost of maintaining accreditation, use of reference materials and calibration of instruments; thus, it is clear that accreditation is an expensive process. Laboratories should find the optimal way to simultaneously meet all these requirements. Service prices are low and number of clients is small and it is unlikely to increase. Therefore, there is a large number of accredited laboratories from the public sector, which are financially supported by the government, while industry is represented by only 13%. On the market there is still unfair competition so that it is impossible to increase the prices of services of accredited laboratories. Research has shown that laboratories in their scope of

zakonskih zahteva za kvalitet i bezbednost proizvoda. Više nego očigledno je da se metode za ispitivanje karakteristika proizvoda koje ne podržavaju ovu regulativu, akredituju u minimalnom broju.

Iz gorenavedenog možemo da zaključimo da cena usluga, nelojalna konkurencija, niska svesnost o standardima, visoki troškovi akreditacije predstavljaju ograničavajući faktor upuštanja laboratorija u proces akreditacije.

I pored svih problema, postoje laboratorije i sertifikaciona tela koja su napravila prve korake i pokazala visoke performanse i dobre rezultate.

Zemlje u razvoju treba da stvore ambijent za uspešnu integraciju svoje ekonomije na evropskom i međunarodnom tržištu. U toku je usaglašavanje makedonskog zakonodavstva sa zakonodavstvom Evropske unije. Zemlje u razvoju treba da imaju u vidu da će bez akreditovanih laboratorija, bez sertifikacionih tela, bez učešća u međulaboratorijskim poređenjima, samo povećati rizik u vezi s plasmanom proizvoda na evropskom tržištu.

accreditation include mainly the methods that support the Regulation, which supports the fact that manufacturers are aiming at meeting the basic minimum legal requirements for product quality and safety. It is more than obvious that the methods for testing the characteristics of products that fail to support this regulation, are accredited to the minimum number.

From the above said it can be concluded that the price of services, unfair competition, low awareness of the standards, the high cost of accreditation, all represent a limiting factor for laboratories to initiate the accreditation process.

Despite all the problems, there are laboratories and certification bodies which had made the first steps and showed high performance and good results.

Developing countries should create an environment for successful integration of their economies in the European and international markets. The process of harmonization of Macedonian legislation with legislation of the European Union is currently underway. Developing countries should bear in mind that without accredited laboratories, certification bodies, and participation in inter-laboratory comparisons, the risk involved in the placement of products on the European market can be only increased.

7 LITERATURA REFERENCE

- [1] Van de Leemput, P. and Tholen, D. (2006). "Measuring up." *ISO Focus*, 3(10), 16-20.
- [2] Mandate M114 – Cement, building limes and other hydraulic binders
- [3] IFM. "IFM Quality Services." <http://www.ifmqs.com.au/what_is_PT.htm> (04 mart, 2013).
- [4] ILAC (2007). "ILAC-G13:07, Guidelines for the Requirements for the Competence of Providers of proficiency testing schemes."
- [5] ISO (2005). "ISO/IEC 17025:2005, General requirements for the competence of testing and calibration laboratories
- [6] ISO (2010). "ISO/IEC 17043:2010, Conformity assessment – General requirements for proficiency testing
- [7] ISO (1997). "ISO/IEC Guide 43-1:1997, Proficiency testing by interlaboratory comparisons – Part 1: Development and operation of proficiency testing schemes."
- [8] ISO (2004). "ISO/IEC 17011:2004, Conformity assessment – General requirements for accreditation bodies accrediting conformity assessment bodies
- [9] Majstorović, V. (2012). "Improving the quality of the laboratory results through PT schemes." *European quality week*, Н.Сад, Србија, 38–43.
- [10] Cherepnalkovska, S. (2012). "Standards are the basis for the improvement and quality assurance." *European quality week*, Н.Сад, Србија.
- [11] Cherepnalkovska, S., Hadzievska-Antovska, L., Popovska, V., (2013) "reating confidence – Mutual recognition of conformity assessment results." *International Working Conference, "Total Quality Management – Advanced and Intelligent Approaches"*, Белград, Србија, 339–344.
- [12] Cherepnalkovska, S., Hadzievska-Antovska, L., Popovska, V., (2012), "Creating confidence-News of conformity assessment." *Пресинг*, 2(11), 36-41.
- [13] Official Journal of the European Union (4.4.2011): Regulation (EU) No 305/2011 of European Parliament and of the Council of 9. March 2011.
- [14] BSI (December 2012): Guidance Note on the Construction Products Regulation.
- [15] EU Commission (September 2002). Guidance Paper B, The definition of Factory Production Control in Technical Specification for Construction products.
- [16] EU Commission (27. May 2004): Guidance Paper D, CE Marking under the Construction Products Directive.
- [17] EU Commission (4. May 2005): Guidance Paper M, Comformity Assessment under CPD: Initial type-testing and Factory production control.
- [18] MKC EN 197-1 Cement – Part 1: Composition, specifications and conformity criteria for common cements
- [19] Business plan of CEN/TC 51
- [20] BT Resolution N10528
- [21] Mandate M114 – Cement, building limes and other hydraulic binders

REZIME

KAKO SMANJITI RIZIK U PROCESU DOKAZIVANJA KVALITETA GRAĐEVINSKIH PROIZVODA

Sonja ČEREPNALKOVSKA
Ljubica VLADIČESKA

Infrastruktura kvaliteta sa svojim komponentama obezbeđuje usklađivanje proizvoda i usluga sa obaveznim zahtevima interesa potrošača i biznisa i doprinosi održavanju kvaliteta proizvoda i usluga. Infrastruktura kvaliteta promoviše izvoz, konkurentnost i inovativnost. Ocenjivanje usaglašenosti pomaže da se obezbedi sigurnost da proizvodi i usluge ispunjavaju očekivanja, drugim rečima: ocenjivanje usaglašenosti gradi poverenje.

U ovom radu, koji je baziran na upitniku, prikazuje se realno stanje, odnosno broj akreditovanih laboratorija u Republici Makedoniji za ispitivanja iz oblasti građevinarstva, kao i učešće u PT šemama, sa akcentom na cement kao ključni proizvod u građevinarstvu.

Ključne reči: akreditacija, ocenjivanje usaglašenosti, međulaboratorijska poređenja, PT šeme.

SUMMARY

HOW TO REDUCE THE RISK IN THE PROVING PROCESS FOR QUALITY CONSTRUCTION PRODUCTS

Sonja CEREPNALKOVSKA
Ljubica VLADICESKA

Quality infrastructure with its components ensures compliance of products and services with the mandatory requirements, interests of consumers and businesses, and contributes to the maintaining of the quality of products and services. Quality infrastructure promotes export, competitiveness and innovation. Conformity assessment helps ensure certainty that products and services deliver on their promises. In other words, conformity assessment builds trust.

This paper, which is based on the questionnaire, presents the real situation or the number of accredited laboratories in the Republic of Macedonia for testing in the field of construction as well as the participation in PT schemes, with an emphasis on the cement as a crucial product in the construction industry.

Key words: accreditation, conformity assessment, inter-laboratory comparison, PT schemes

UPUTSTVO AUTORIMA*

Prihvatanje radova i vrste priloga

U časopisu Materijali i konstrukcije štampaće se neobjavljeni radovi ili članci i konferencijska saopštenja sa određenim dopunama, iz oblasti građevinarstva i srodnih disciplina (geodezija i arhitektura). Vrste priloga autora i saradnika koji će se štampati su: originalni naučni radovi, prethodna saopštenja, pregledni radovi, stručni radovi, prikazi objekata i iskustava (studija slučaja), kao i diskusije povodom objavljenih radova.

Originalni naučni rad je primarni izvor naučnih informacija i novih ideja i saznanja kao rezultat izvornih istraživanja uz primenu adekvatnih naučnih metoda. Dobijeni rezultati se izlažu sažeto, ali tako da poznavalac problema može proceniti rezultate eksperimentalnih ili teorijsko numeričkih analiza, tako da se istraživanje može ponoviti i pri tome dobiti iste ili rezultate u okvirima dopuštenih odstupanja, kako se to u radu navodi.

Prethodno saopštenje sadrži prva kratka obaveštenja o rezultatima istraživanja ali bez detaljnih objašnjenja, tj. kraće je od originalnog naučnog rada.

Pregledni rad je naučni rad koji prikazuje stanje nauke u određenoj oblasti kao plod analize, kritike i komentara i zaključaka publikovanih radova o kojima se daju svi neophodni podaci pregledno i kritički uključujući i sopstvene radove. Navode se sve bibliografske jedinice korišćene u obradi tematike, kao i radovi koji mogu doprineti rezultatima daljih istraživanja. Ukoliko su bibliografski podaci metodski sistematizovani, ali ne i analizirani i raspravljani, takvi pregledni radovi se klasifikuju kao stručni radovi.

Stručni rad predstavlja koristan prilog u kome se iznose poznate spoznaje koje doprinose širenju znanja i prilagođavanja rezultata izvornih istraživanja potrebama teorije i prakse.

Ostali priloci su prikazi objekata, tj. njihove konstrukcije i iskustava-primeri u građenju i primeni različitih materijala (studije slučaja).

Da bi se ubrzao postupak prihvatanja radova za publikovanje, potrebno je da autori uvažavaju Uputstva za pripremu radova koja su navedena u daljem tekstu.

Uputstva za pripremu rukopisa

Rukopis otkucati jednostrano na listovima A-4 sa marginama od 31 mm (gore i dole) a 20 mm (levo i desno), u Wordu fontom Arial sa 12 pt. Potrebno je uz jednu kopiju svih delova rada i priloga, dostaviti i elektronsku verziju na navedene E-mail adrese, ili na CD-u. Autor je obavezan da čuva jednu kopiju rukopisa kod sebe.

Od broja 1/2010, prema odluci Upravnog odbora Društva i Redakcionog odbora, radovi sa pozitivnim recenzijama i prihvaćeni za štampu, publikovaće se na srpskom i engleskom jeziku, a za inostrane autore na engleskom (izuzev autora sa govornog područja srpskog i hrvatskog jezika).

Svaka stranica treba da bude numerisana, a optimalni obim članka na jednom jeziku, je oko 16 stranica (30000 slovnih mesta) uključujući slike, fotografije, tabele i popis literature. Za radove većeg obima potrebna je saglasnost Redakcionog odbora.

* Uputstvo autorima je modifikovano i treba ga, u pripremi radova, slediti.

GUIDELINES TO AUTHORS

Acceptance and types of contributions

The Building Materials and Structures journal will publish unpublished papers, articles and conference reports with modifications in the field of Civil Engineering and similar areas (Geodesy and Architecture). The following types of contributions will be published: original scientific papers, preliminary reports, review papers, professional papers, objects describe / presentations and experiences (case studies), as well as discussions on published papers.

Original scientific paper is the primary source of scientific information and new ideas and insights as a result of original research using appropriate scientific methods. The achieved results are presented briefly, but in a way to enable proficient readers to assess the results of experimental or theoretical numerical analyses, so that the research can be repeated and yield with the same or results within the limits of tolerable deviations, as stated in the paper.

Preliminary report contains the first short notifications on the results of research but without detailed explanation, i.e. it is shorter than the original scientific paper.

Review paper is a scientific work that presents the state of science in a particular area as a result of analysis, review and comments, and conclusions of published papers, on which the necessary data are presented clearly and critically, including the own papers. Any reference units used in the analysis of the topic are indicated, as well as papers that may contribute to the results of further research. If the reference data are methodically systematized, but not analyzed and discussed, such review papers are classified as technical papers.

Technical paper is a useful contribution which outlines the known insights that contribute to the dissemination of knowledge and adaptation of the results of original research to the needs of theory and practice.

Other contributions are presentations of objects, i.e. their structures and experiences (examples) in the construction and application of various materials (case studies).

In order to speed up the acceptance of papers for publication, authors need to take into account the Instructions for the preparation of papers which can be found in the text below.

Instructions for writing manuscripts

The manuscript should be typed one-sided on A-4 sheets with margins of 31 mm (top and bottom) and 20 mm (left and right) in Word, font Arial 12 pt. The entire paper should be submitted also in electronic format to e-mail address provided here, or on CD. The author is obliged to keep one copy of the manuscript.

As of issue 1/2010, in line with the decision of the Management Board of the Society and the Board of Editors, papers with positive reviews, accepted for publication, will be published in Serbian and English, and in English for foreign authors (except for authors coming from the Serbian and Croatian speaking area).

Each page should be numbered, and the optimal length of the paper in one language is about 16 pages (30.000 characters) including pictures, images, tables and references. Larger scale works require the approval of the Board of Editors.

Naslov rada treba sa što manje reči (poželjno osam, a najviše do jedanaeset) da opiše sadržaj članka. U naslovu ne koristiti skraćenice ni formule. U radu se iza naslova daju ime i prezime autora, a titule i zvanja, kao i ime institucije u podnožnoj napomeni. Autor za kontakt daje telefon, adresu elektronske pošte i poštansku adresu.

Uz sažetak (rezime) od oko 150-250 na srpskom i engleskom jeziku daju se ključne reči (do sedam). To je jezgrovit prikaz celog članka i čitaocima omogućuje uvid u njegove bitne elemente.

Rukopis se deli na poglavlja i potpoglavlja uz numeraciju, po hijerarhiji, arapskim brojevima. Svaki rad ima uvod, sadržinu rada sa rezultatima, analizom i zaključcima. Na kraju rada se daje popis literature.

Kod svih dimenzionalnih veličina obavezna je primena međunarodnih SI mernih jedinica.

Formule i jednačine treba pisati pažljivo vodeći računa o indeksima i eksponentima. Autori uz izraze u tekstu definišu simbole redom kako se pojavljuju, ali se može dati i posebna lista simbola u prilogu.

Prilozi (tabele, grafikoni, sheme i fotografije) rade se u crno-belom tehničkom, u formatu koji obezbeđuje da pri smanjenju na razmere za štampu, po širini jedan do dva stupca (8 cm ili 16,5 cm), a po visini najviše 24,5 cm, ostanu jasni i čitljivi, tj. da veličine slova i brojeva budu najmanje 1,5 mm. Originalni crteži treba da budu kvalitetni i u potpunosti pripremljeni za presnimavanje. Mogu biti i dobre, oštre i kontrastne fotokopije. Koristiti fotografije, u crno-belom tehničkom, na kvalitetnoj hartiji sa oštrim konturama, koje omogućuju jasnu reprodukciju.

U popisu literature na kraju rada daju se samo oni radovi koji se pominju u tekstu. Citirane radove treba prikazati po abecednom redu prezimena prvog autora. Literaturu u tekstu označiti arapskim brojevima u uglastim zagradama, kako se navodi i u Popisu citirane literature, napr [1]. Svaki citat u tekstu mora se naći u Popisu citirane literature i obrnuto svaki podatak iz Popisa se mora citirati u tekstu.

U Popisu literature se navode prezime i inicijali imena autora, zatim potpuni naslov citiranog članka, iza toga sledi ime časopisa, godina izdavanja i početna i završna stranica (od - do). Za knjige iza naslova upisuje se ime urednika (ako ih ima), broj izdanja, prva i poslednja stranica poglavlja ili dela knjige, ime izdavača i mesto objavljivanja, ako je navedeno više gradova navodi se samo prvi po redu. Kada autor citirane podatke ne uzima iz izvornog rada, već ih je pronašao u drugom delu, uz citat se dodaje «citirano prema...».

Autori su odgovorni za izneseni sadržaj i moraju sami obezbediti eventualno potrebne saglasnosti za objavljivanje nekih podataka i priloga koji se koriste u radu.

Ukoliko rad bude prihvaćen za štampu, autori su dužni da, po uputstvu redakcije, unesu sve ispravke i dopune u tekstu i prilozima.

Rukopisi i prilozi objavljenih radova se ne vraćaju. Sva eventualna objašnjenja i uputstva mogu se dobiti od Redakcionog odbora.

Radovi se mogu slati i na e-mail: folic@uns.ac.rs ili miram@uns.ac.rs

Veb sajt Društva i časopisa: www.dimk.rs

The title should describe the content of the paper using a few words (preferably eight, and up to eleven). Abbreviations and formulas should be omitted in the title. The name and surname of the author should be provided after the title of the paper, while authors' title and position, as well as affiliation in the footnote. The author should provide his/her phone number, e-mail address and mailing address.

The abstract (summary) of about 150-250 words in Serbian and English should be followed by key words (up to seven). This is a concise presentation of the entire article and provides the readers with insight into the essential elements of the paper.

The manuscript is divided into chapters and sub-chapters, which are hierarchically numbered with Arabic numerals. The paper consists of introduction and content with results, analysis and conclusions. The paper ends with the list of references. All dimensional units must be presented in international SI measurement units. The formulas and equations should be written carefully taking into account the indexes and exponents. Symbols in formulas should be defined in the order they appear, or alternatively, symbols may be explained in a specific list in the appendix. Illustrations (tables, charts, diagrams and photos) should be in black and white, in a format that enables them to remain clear and legible when downscaled for printing: one to two columns (8 cm or 16.5 cm) in height, and maximum of 24.5 cm high, i.e. the size of the letters and numbers should be at least 1.5 mm. Original drawings should be of high quality and fully prepared for copying. They also can be high-quality, sharp and contrasting photocopies. Photos should be in black and white, on quality paper with sharp contours, which enable clear reproduction.

The list of references provided at the end of the paper should contain only papers mentioned in the text. The cited papers should be presented in alphabetical order of the authors' first name. References in the text should be numbered with Arabic numerals in square brackets, as provided in the list of references, e.g. [1]. Each citation in the text must be contained in the list of references and vice versa, each entry from the list of references must be cited in the text.

Entries in the list of references contain the author's last name and initials of his first name, followed by the full title of the cited article, the name of the journal, year of publication and the initial and final pages cited (from - to). If the doi code exists it is necessary to enter it in the references. For books, the title should be followed by the name of the editor (if any), the number of issue, the first and last pages of the book's chapter or part, the name of the publisher and the place of publication, if there are several cities, only the first in the order should be provided. When the cited information is not taken from the original work, but found in some other source, the citation should be added, "cited after ..."

Authors are responsible for the content presented and must themselves provide any necessary consent for specific information and illustrations used in the work to be published.

If the manuscript is accepted for publication, the authors shall implement all the corrections and improvements to the text and illustrations as instructed by the Editor.

Writings and illustrations contained in published papers will not be returned. All explanations and instructions can be obtained from the Board of Editors.

Contributions can be submitted to the following e-mails: folic@uns.ac.rs or miram@uns.ac.rs

Website of the Society and the journal: www.dimk.rs

Izdavanje časopisa "Građevinski materijali i konstrukcije" finansijski su pomogli:



INŽENJERSKA KOMORA SRBIJE



**REPUBLIKA SRBIJA
MINISTARSTVO PROSVETE, NAUKE I
TEHNOLOŠKOG RAZVOJA**



**UNIVERZITET U BEOGRADU
GRAĐEVINSKI FAKULTET**



**DEPARTMAN ZA GRAĐEVINARSTVO I
GEODEZIJU
FAKULTET TEHNIČKIH NAUKA NOVI SAD**



INSTITUT IMS AD, BEOGRAD



**UNIVERZITET CRNE GORE
GRAĐEVINSKI FAKULTET - PODGORICA**



KOTO



IZOMONT d.o.o. BEOGRAD Preduzeće za završne radove u građevinarstvu inženjering i konsalting

KVALITET **POD** NOGAMA

Kompanija IZOMONT D.O.O. iz Beograda bavi se izvođenjem završnih radova u građevinarstvu. Prvenstveno smo specijalizovani za betoniranja, izradu industrijskih podova i hidroizolacija.

HODROIZOLACIJA BETONIRANJE INDUSTRIJSKI PODOVI

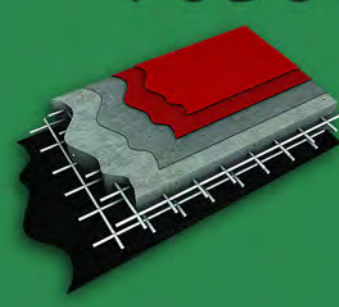
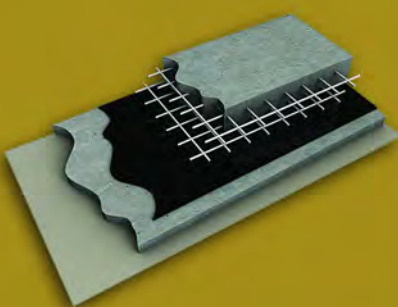
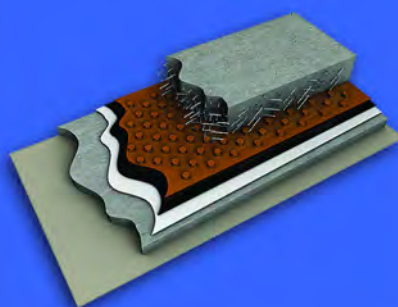

IZOMONT d.o.o.
Bulevar Patrijarha
Germana 202
11226 Beograd
Republika Srbija

Telefon:
Tel: +381 11 3907 923
Fax: +381 11 3907 921

Web:
izomont@gmail.com
www.izomont.co.rs

**Građevinska hemija
za profesionalce**



TKK DODACI ZA BETONE I MALTERE I ZAŠTITNI PRAKOVANJE

CEMENTOL

dodaci za proizvodnju trajnog i kvalitetnog betona

SILIFOB

vodootporne i druge zaštite mineralnih i drugih građevinskih materijala



www.tkk.rs

TKK d.o.o., Ugrinovačka 206, 11080 Zemun

Tel: +381 11 316 91 10, M: +381 641 549 007, office@tkk.rs

PROIZVODI ZA VELIKE PROJEKTE, BRANE, KANALE, VIJADUKTE

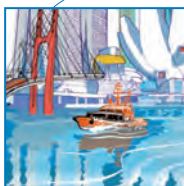

ADITIVI ZA BETON

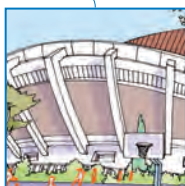

PROIZVODI ZA PODZEMNE KONSTRUKCIJE



PROIZVODI ZA OBNOVU ISTORIJSKIH OBJEKATA

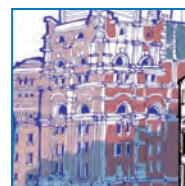
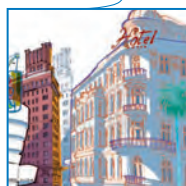

PROIZVODI ZA STRUKTURALNO OJAČAVANJE

PROIZVODI ZA GRAĐEVINARSTVO



ZIDNI ZAŠTITNI I DEKORATIVNI PREMAZI



PROIZVODI ZA HIDROIZOLACIJU



PROIZVODI ZA KERAMIČKE PLOČICE I KAMEN

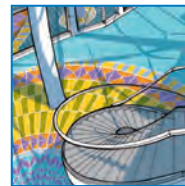

ELASTIČNE MASE ZA ZAPTIVANJE I LEPKOVI

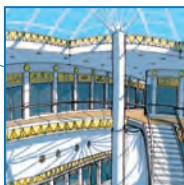

PROIZVODI ZA AKUSTIČKU IZOLACIJU



PROIZVODI ZA ODRŽAVANJE PUTEVA



PROIZVODI ZA PODOVE NA BAZI CEMENTA I SINTETIČKIH SMOLA



PROIZVODI ZA OPREMANJE JAVNIH PROSTORA



PROIZVODI ZA PODOVE OD DRVETA



PROIZVODI ZA TERMIČKU IZOLACIJU



PROIZVODI ZA ELASTIČNE I TEKSTILNE PODNE OBLOGE



PROIZVODI ZA SPORTSKE OBJEKTE

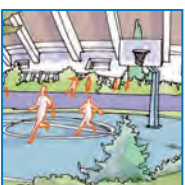

PROIZVODI ZA BICIKLISTIČKE STAZE



PROIZVODI ZA VEŠTAČKE I PRIRODNE TRAVNATE POVRŠINE



SVET MAPEI
SVE KVALITETNO
I VREDNO
U GRAĐEVINARSTVU

Ilustrovao: Carlo Sanga



/mapeispa

Za više informacija posetite:
www.mapei.rs





CEMENT. AGREGATI. BETON.

Kompanija CRH je vodeći diversifikovani proizvođač građevinskih materijala na svetu. CRH u Srbiji proizvodi cement, agregate i beton. CRH je posvećen unapređivanju građevinske delatnosti kroz isporuku vrhunskih materijala i proizvoda za sprovođenje i održavanje infrastrukturnih, stambenih i komercijalnih projekata. Naša kompanija za ekološka rešenja Ecorec nudi usluge odgovornog upravljanja otpadom.

www.crhserbia.com

MARTEST



ROLLER COMPACTOR

HAMBURG WHEEL TRACKER

WHEEL TRACKING APPARATUS

SMARTRACKER

GYRATORY COMPACTOR



AUTOMATIC MODULUS OF ELASTICITY

SERVO PLUS

FLEXURAL TEST WITH THE OPEN SIDE FRAME

ENERGY ABSORPTION TEST



"EDOTRONIC" AUTOMATIC CONSOLIDATION APPARATUS

DIGITAL TRIAXIAL MACHINE

DATA ACQUISITION AND PROCESSING SYSTEM FOR GEOTECHNICAL TESTS

DIRECT/RESIDUAL SHEAR TEST APPARATUS

25 YEARS OF **EXPERIENCE**
IS SOMETHING THAT YOU CAN'T BUY



INELAS ERECO D.O.O

Inelas Eresco d.o.o. se bavi prodajom i servisiranjem laboratorijske opreme u domenu ispitivanja građevinskih materijala kao što su

- Agregati - Asfalt, bitumen i putevi - Beton - Cement i malter - Čelik - Zemljište
- Opšta laboratorijska oprema

Inelas Eresco d.o.o. Tošin bunar 274a, Novi Beograd
tel +381 11 2284 574, info@inelasereco.rs

Učestvuj u stvaranju arhitekture budućnosti

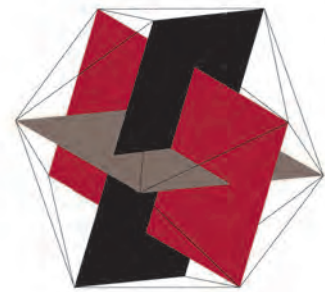

LafargeHolcimAwards

5. Međunarodna LafargeHolcim Nagrada za projekte održive gradnje

- ✓ Ukupni nagradni fond: 2.000.000 USD
- ✓ Posebna kategorija **Nova generacija** za mlade profesionalce i studente
- ✓ Prijave do 21. marta 2017.
na www.lafargeholcim-awards.org/enter



Korak po korak vodič za prijavu možeš pronaći na www.lafargeholcim-awards.org/guide

NAPREDNA SIKA REŠENJA U OBLASTI STRUKTURALNIH OJAČANJA

Kompanija Sika pruža trajnu dodatnu vrednost vlasnicima građevinskih objekata, njihovim konsultantima i izvođačima, kao i tehničku podršku tokom svih faza projekta,

od ispitivanja uslova i razvoja inicijalnog koncepta ojačanja pa sve do uspešnog završetka i primopredaje projekta

SIKA - VAŠ PARTNER NA GRADILIŠTU



- Globalni lider na tržištu građevine i građevinske hemije
- Najbolja tehnička ekspertiza i praksa za sanaciju betona i strukturalna ojačanja
- Odlična reputacija kod vodećih izvođača i ugovarača posla

SIKA VREDNOSTI I INOVACIJE U GRAĐEVINI

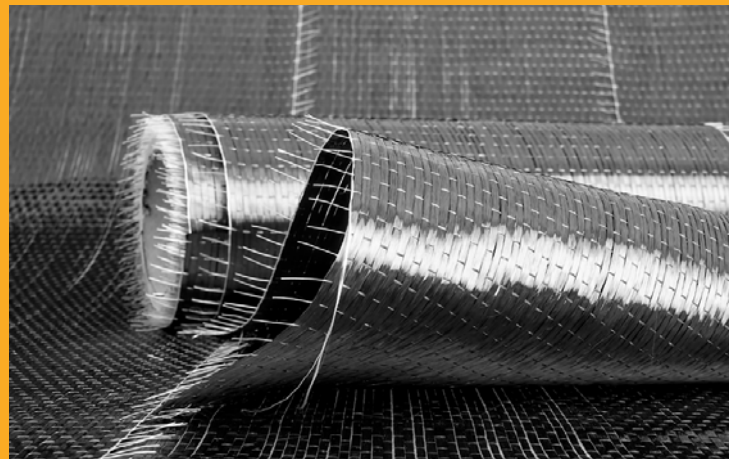

- Integrirani proizvodi i sistemi visokih performansi koji mogu da povećaju i poboljšaju kapacitet, efikasnost, trajnost i estetiku zgrada i drugih objekata – u korist naših klijenata i boljeg održivog razvoja
- Sika mreža obučenih i iskusnih građevinskih stručnjaka

JEDINSTVENA SIKA REŠENJA U ZAHTEVNIM USLOVIMA



- Rešenja za gotovo sve uslove apliciranja
- Kontrolisano vreme rada, vreme sazrevanja i očvršćavanja za različite vremenske uslove
- Posebna rešenja završnih ojačanja za korišćenje kod betona slabije jačine i drugih podloga

POTVRĐENI SIKA SISTEMI I TEHNIKE APLICIRANJA



- Preko 40 godina iskustva u strukturalnim ojačanjima, sistemima i tehnikama
- Proizvodi i sistemi sa brojnim testovima i procenama kako internim tako i eksternim
- Najviši međunarodni standardi proizvodnje i kontrole kvaliteta



doka

Oplatna tehnika.

Vaš pouzdan partner

za brzu, bezbednu i ekonomičnu gradnju!

Doka Serb je srpski ogranak austrijske kompanije **Doka GmbH**, jednog od svetskih lidera na polju inovacija, proizvodnje i distribucije oplatnih sistema za sve oblasti građevinarstva. Delatnost kompanije Doka Serb jeste isporuka oplatnih sistema i komponentni za primenu u visokogradnji i niskogradnji, pružanje usluga konsaltinga, izrade tehničkih planova i asistencije na gradilištu.

Panelna oplata za ploče Dokadek 30 – Evolucija u sistemima oplata za ploče

Dokadek 30 je ručna oplata lake čelične konstrukcije, bez nosača sa plastificiranim ramovima, koji su prekriveni kompozitnim drveno-plastičnim panelom površine do 3 m².

Izuzetno brzo, bezbedno i lako postavljanje oplata

- Mali broj delova sistema i pregledna logistika uz samo dve veličine panela (2,44 x 1,22 m i 2,44 x 0,81 m)
- Dovoljan 2-člani tim za jednostavnu i brzu montažu elemenata sa tla bez merdevina i bez kрана
- Sistemski određen položaj i broj podupirača i panela, unapred definisan redosled postupaka
- Prilagođavanje svim osnovama zahvaljujući optimalnom uklapanju sa Dokaflex-om
- Specijalni dizajn sprečava odizanje panela pod uticajem vetra
- Horizontalno premeštanje do 12 m² Dokadek 30 pomoću DekDrive

Više informacija o sistemu naći ćete na našem sajtu www.doka.rs

Doka Serb d.o.o. | Svetogorska 4, 22310 Šimanovci | Srbija | T +381 22 400 100
F +381 22 400 124 | serb@doka.com | www.doka.rs





Zajedno gradimo održive veze

TITAN Cementara Kosjerić deo je TITAN Grupe, multiregionalnog, vertikalno integrisanog proizvođača cementa i građevinskih materijala, sa preko 115 godina poslovnog iskustva. Grupa, čije je sedište u Grčkoj, posluje u 10 zemalja i zapošljava više od 5.500 ljudi širom sveta. Kroz svoju istoriju, TITAN je uvek kombinovao vrhunsku operativnost sa poštovanjem ljudi, društva i životne sredine.

Naš uspeh zasnovan je na korišćenju najboljih dostupnih tehnologija, sistematičnom istraživanju, stalnom unapređenju znanja i vrhunskoj stručnosti naših zaposlenih. Održivi razvoj je integralni deo našeg poslovanja, a negovanje i jačanje saradnje sa svim stejkholderima od vitalnog značaja za postavljanje čvrste osnove za održivu i bolju budućnost za sve.

Titan Cementara Kosjerić d.o.o.
Živojina Mišića b.b.
31260 Kosjerić, Srbija

www.titan.rs

